

**SONIFEX**

Catalogue <sup>2021</sup>





# SONIFEX

## Welcome To The New Sonifex Catalogue For 2021

Made in the UK by  
**SONIFEX**



Welcome to the new Sonifex catalogue for 2021. We have a number of new products, (see pages iv-v) which have been added to our extensive brand lines.

We've got a heritage of building products of the highest quality in the UK and we're proud to be a British manufacturer. Most British radio & TV broadcast studios have used Sonifex equipment and we currently export on average 70% of our products, supplying equipment to over 60 countries world-wide. We're recognised for the high quality and reliability of our designs, in recognition of both the excellent technical audio/video quality and also the practical design and pleasant aesthetic appearance of our products.

By keeping as much of the design and manufacturing processes in house as possible, we can control the quality needed to service the broadcast industry, where 24/7/365 operation is a requirement.

We have our own R&D team to design hardware and software, two surface mount PCB assembly lines with in-line product testing and a full engineering workshop. The production and stocking areas use a product bar-coding system, so that we can more tightly control and guarantee the high quality of the products that you're buying.

The constant need to innovate is now an integral part of our culture, combining healthy and outward-looking ideas with

sound and efficient design practices. We are expanding our position in the broadcasting industry by increasing our R&D efforts in order to offer new designs of equipment reflecting the quality and reliability that is expected by you, our customers.

We hope that this catalogue contains the products that you need, but if it doesn't then give us a call, we often manufacture bespoke products for customers.

Thank you for using our products.

**Marcus Brooke**  
Managing Director, Sonifex Ltd

### 2 Year Warranty

You can go online to extend your standard 1 year warranty to 2 years at: <http://www.sonifex.co.uk/technical/register/index.asp>

### Key to Symbols:

When the symbol is not in use it is coloured grey. When active, the symbol is gold.



Radio Broadcasting Studio/Engineering



Radio Broadcasting Transmission



TV Broadcasting Studio/Engineering



OB Vans/Trucks



Pro Audio



Post Production



Live Sound/PA



Commercial Infrastructure



Security



Education



Controlled via RS232 or Ethernet using the free of charge Sonifex Control Interface (SCI) software.



Built-in web server for control via a web browser.



# SONIFEX

## RESEARCH AND PRODUCTION

P Visitors

P Visitors

Reception & Main Entrance  
SONIFEX

CCTV 24hr  
SONIFEX

23



# Contents

<b>What's New?</b>	iv	<b>Audio Logging</b>	159
<b>Audio Monitors, Meters &amp; Monitor Controllers</b>	1	Net-Log Network Audio Logger	160
Reference Monitors	2	Net-Log-Win Software	162
Confidence Monitors	14	Mentor Time-Server	165
Reference Monitor Meters	18	PC-FLS8 Flashlog 8 Audio & Radio Capture Logging Software	166
Reference Monitor Controllers	23		
<b>Redbox Audio &amp; Video Interfaces</b>	29	<b>Radio Broadcast Mixing Consoles</b>	171
Redbox Introduction	30	S0v2 Radio Broadcast On-Air Mixer	172
Rackmount Kits	31	S1 Radio Broadcast On-Air Mixer	176
3G/HD/SD-SDI Video Distribution Amplifiers	32	S2 Digital I/O Analogue Radio Broadcast Mixer	182
3G/HD/SD-SDI Video Embedders & De-Embedders	35	<b>Radio Studio Packages</b>	207
Digital Audio Converters	44	Monitor Speaker Stands	208
Synchronisation Add-On Boards	54		
Synchronisers, Delays & Silence Detectors	55	<b>Talkback &amp; Commentary</b>	209
Matching Converters	78	Talkback Controller Units	210
Audio Distribution Amplifiers	87	Gooseneck Condenser Microphone	215
Phantom Power Supply	108	Commentator Units	216
Headphone Distribution Amplifiers	109	Belt-Packs	224
Mixers, Source Selectors & Switchers	114	Talkback Intercoms	226
Microphone Amplifiers & Limiters	127	<b>Telephony &amp; Communications</b>	231
Stereo to Mono Converters	134	Line Powered Hybrids	234
Power Controllers	136	Analogue Telephone Hybrids	236
Talkback & Communications	137	Digital Telephone Hybrids	238
Tone Generators	142	Digital GSM Hybrids	2544
<b>Portable Distribution Amps</b>	145	Digital HD Voice Hybrids	246
		Pro Audio Streamers	251
<b>Professional PCIe Sound Cards &amp; Radio Capture Cards</b>	149	<b>Studio Illuminated Signs</b>	259
Professional PCIe Sound Cards	150	SignalLED Range of LED Signs	260
Radio Capture Cards	155	Custom Signs	262
		<b>Index</b>	265

## New Products



### Multi-Channel Dante® Audio Interfaces

These new Dante® audio interfaces convert balanced analogue or AES3 inputs and outputs to Dante AoIP. For analogue I/O, 4 and 8 channels bidirectionally, 16 channel inputs and 16 channel outputs are catered for. On these analogue products, global line up level can be set for inputs and outputs. For AES3 there is an 8 stereo channel

bidirectional interface. All analogue and AES3 models can be ordered with either single or dual redundant Dante ports. Simple to configure and operate, these cost effective rack-mount solutions offer an easy solution for AV professionals and system integrators.



**AVN-AIO4** 4 Input, 4 Output Dante® Interface, PoE



**AVN-AI16R** 16 Input Dual Dante® Interface, POE



**AVN-AESIO8R** 8 AES Input, 8 AES Output Dual Dante® Interface, POE



**AVN-AIO8R** 8 Input, 8 Output, Dual Dante® Interface, PoE



**AVN-AO16R** 16 Output Dual Dante® Interface, POE

### Dante® Voiceover Unit

**AVN-MTV1R-DANTE** Dante Contribution Voiceover Monitor with Talkback



### AVN-DIO10 Dante to 3G/HD/SD-SDI Embedder & De-Embedder

The easiest way to connect legacy SDI equipment to the Dante® network, the AVN-DIO10 can be used for simultaneous embedding and de-embedding.



## New Products



## New Dante® AoIP Commentator Unit

### AVN-CU2-DANTE Configurable Dante Commentary Unit for 2 Commentators

The AVN-CU2-DANTE takes a new approach to provide a multi-purpose configurable tool for commentary teams. Its power lies in the impressive mix engine which overlays the usual Dante® Controller settings. Once Dante® flows have been made, inputs and outputs can be mixed freely to AoIP or physical inputs and outputs, controlled using the programmable buttons and rotary encoders, which control the gain and pan of inputs, outputs or cross-points, allowing total flexibility for different situations.



### AVN-CU4-DANTE Commentator Unit, 4 Commentators

The AVN-CU4-DANTE is a portable commentator unit using Dante® AoIP. It is a dual version of the AVN-CU2-DANTE providing four mic/line inputs with a wide, adjustable gain range and four stereo headphone outputs with lockable jack sockets, suitable for operation by three or four commentators.



## DIO Audiophile Dante® Interfaces

If you're putting audio onto your Dante® network, make it the best audio quality that it can be. Introducing the new DIO audiophile Dante® interfaces. These simple plug and play audio interfaces provide a convenient and elegant method of connecting legacy analogue and digital audio equipment to the Dante AoIP audio network.



**AES67** now!



RAVENNA



## Multi-Channel Audio Mix Engine Interfaces Using AES67 AoIP - the AVN Portals

Each of the 3 portals can be ordered either with the input/output metering displays (D version) or without and a rear panel connectivity - with XLR/RJ45 connectors or terminal block (T version) connectors.

### AVN-PA8D 8 x Stereo Analogue Line Inputs & Outputs, AES67 Display Portal



The AVN-PA8 uses D-type sockets with AES59 analogue pinout, paralleled with 8 x RJ45 connectors using StudioHub® pinout. It can also receive AoIP streams from 16 additional AES67 sources and can send to 64 additional AoIP destinations.

### AVN-PD8 8 x Stereo AES3 Digital Inputs & Outputs, AES67 Portal



The AVN-PD8 has 8 x stereo AES3 digital line inputs & outputs on D-type sockets with AES59 pinout, paralleled with 8 x RJ45 connectors using StudioHub® pinout. It has individual input sample rate conversion, input and output gain adjustment and has the same streaming facilities as the AVN-PA8, i.e. 16 additional AES67 stream inputs and outputs which can be mixed and routed together with the physical I/O.

### AVN-PM8 8 x Mic/Line Inputs & 8 x Line Outputs, AES67 Portal



The AVN-PM8 has 8 x mic/line inputs and 8 x stereo line outputs on D-type sockets with AES59 analogue pinout, paralleled with 8 x RJ45 connectors using StudioHub® pinout. +48V phantom power is available for each microphone input with a red LED presence indication.

SOURCE



BANK



SONIFEX

PHASE

5 1

6 2

7 3

8 4



A

B

EX D

1

2



1



2

3

5

4

6



3

4

7

0







## Audio Monitors, Meters & Monitor Controllers

The Reference Monitor range offers a number of solutions for monitoring:

### Reference Monitor Rackmount Audio Monitors

A range of 1U rack-mount monitors offering loudspeaker monitoring & bar-graph LED metering of multiple audio inputs.

2

### Confidence Monitors

Using the same outstanding speaker system as the Reference Monitor range, the confidence monitors offer a superb sound with simple controls.

14

### Reference Monitor Meters

Using the same accurate precision LED bar-graph meters, these products are for visual metering of many analogue or digital audio inputs.

18

### Reference Monitor Controllers

For use in controlling the level to a pair of speakers, or 5.1 surround sound system, together with transmission light-sign control.

23



Image of Sonifex Reference Monitors in an HD-OB truck.  
Photo supplied courtesy of Broadcast Solutions GmbH.



## Reference Monitor Rackmount Audio Monitors

The three monitors in the range are:

**RM-2S4** Reference Monitor, 2 LED meters, 4 stereo channel audio inputs.

**RM-2S10** Reference Monitor, 2 LED meters, 10 stereo channel audio inputs.

**RM-4C8** Reference Monitor, 4 LED meters, 8 channel inputs, dual selectors.

The Reference Monitor Range is a series of rack-mount audio monitors, combining the latest DSP technology with outstanding audio enclosure design to produce monitors of the highest standards with exceptional sound quality, a comprehensive feature set and good looks in the rack.

Uniquely an embedded 5 band parametric EQ allows you to configure the monitor for your environment or to suit your listening tastes.

### Detail In The Design

In the design of the product, every care has been taken to ensure the best and most accurate reproduction of the audio sources.

In a 1U rack, the propagation of high power sound waves in such a small enclosure could have a tendency to produce rattles or move components, but the Reference Monitors

have been designed to ensure that their audio performance is not compromised.

### Anti-Vibration

A welded and sealed stainless-steel case with milled aluminium fascia provides exceptional rigidity and has been used to ensure that there are no extraneous metallic rattles. The lid is sealed with extensive thin foam cut-outs to provide damping to the lid and multi-point screw fixings are used to ensure lid rigidity.

The XLR and USB port connectors on the rear panel are sealed with foam, and silicon sealant is used on components which could move, or vibrate, under high SPL conditions.

### Accurate Sound System

The speaker system comprises a three-way arrangement with two mid/high frequency speakers providing excellent stereo imaging and a separately driven, forward facing, dual magnet, mono bass driver.

Custom-moulded, profiled, HF enclosures are used to minimise standing waves and eliminate response peaks, and acoustic damping in the HF enclosures is used to reduce colouration, effectively creating a separate, sealed, infinite-baffle enclosure for each driver.

Each speaker uses a separate, highly efficient class-D switching amplifier.

Even cable lengths to and from the speaker enclosures have been kept short to reduce any potential microphonic induction.

### Audio Modifiers

Six illuminated soft-touch pushbuttons allow front panel muting and dimming of the loudspeakers, stereo-to-mono conversion, phase inversion and Middle+Side encoding/decoding with all front panel settings stored in non-volatile memory which is recalled at power-up. A universal power supply ensures global voltage operation without adjustment.



Six illuminated soft-touch pushbuttons.

### DSP Based Design

The use of a modern electronic architecture allows a much better audio performance to be realised. The DSP-based, 3rd-order active crossover provides perfect separation between mid-range and bass sounds.

A DSP-based electronic equalisation is used to flatten the frequency response and also enables the 5 band parametric EQ. Additionally, the fast-attack DSP loudspeaker limiter protects the drivers from overload damage.

### Optional HD Expansion Cards

A number of plug-in expansion cards are available allowing multiple AES groups embedded within an HD-SDI or SD-SDI signal to be de-embedded and monitored, or allowing Dolby® E or Dolby® Digital encoded signals to be monitored directly:

- RM-HD1** HD-SDI expansion card.
- RM-HDE1** HD-SDI & Dolby® E expansion card.
- RM-E1X** Dolby® E expansion card, XLR.
- RM-E1B** Dolby® E expansion card, BNC.

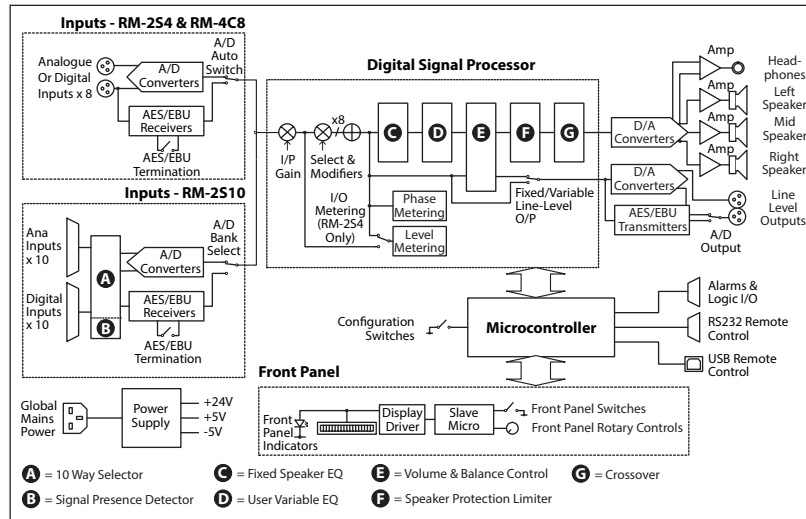

Reference Monitor Block Diagram.

### 5 Band Parametric Equalisation

Each product in the Reference Monitor range contains an embedded 5 band parametric equaliser.

The Reference Monitor products are often installed in OB trucks or engineering rooms where the acoustics aren't ideal. The addition of a 5 band parametric EQ allows you to alter the sound of your

monitor to account for the acoustic conditions, or to suit your particular listening tastes.

Using the free of charge Sci remote control software, preset EQ settings can be selected, or different EQ settings can be created and stored.

### Available Scales/Ballistics For Reference Monitors

There are nine scales available with accurately modelled ballistics. Each stereo meter pair can have a different scale, set via a DIPswitch on the underside.

A complete set of overlays are provided per stereo meter so that you can define the scale(s) that you need:

1. Dual BBC PPM + standard VU
2. BBC PPM IEC60268-10 11a
3. EBU PPM IEC60268-10 11b
4. Nordic PPM IEC60268-10 1
5. AES/EBU digital PPM IEC60268-18
6. DIN PPM DIN45406
7. Standard VU IEC60268-17
8. Extended VU IEC60268-17
9. German PPM



## RM-2S4 Reference Monitor, 2 LED Meters & 4 Stereo Inputs



**Category:** Reference Monitors

**Product Function:** Audible and visual metering of audio sources.

**Typical Applications:** Monitoring of multiple audio sources in an OB truck or engineering racks room.

**Features:** 3 speaker system, 5 band parametric EQ, phase meter, audio modifiers, multiple scales, analogue and digital inputs, superb sound, option for HD/SD-SDI de-embedding.

The RM-2S4 is a 1U rackmount unit offering quality loudspeaker monitoring and accurate, high-resolution metering of up to four stereo audio sources and more with the addition of optional expansion cards. Sources may be in any mixture of analogue and AES/EBU digital formats, with sample rates up to 192kHz accepted.

Audio inputs can be analogue or digital because they are autoswitching using the left Neutrik™ XLR for AES/EBU, or both Neutrik™ XLRs for analogue inputs and they can be used in any combination.

Analogue inputs can be balanced or unbalanced. The digital inputs have switchable AES/EBU termination for (close-range) bridging operation and there is extra global input gain available for both analogue and digital low-level sources.

Sources (and additional banks of sources, if fitted) are selected via a front panel rotary encoder, with clear LED indication of the current selection.

A pair of line level audio outputs, follow the selected source at either a fixed level or one mirroring the loudspeaker volume.

The level of the chosen source is displayed on a pair of bright, multicoloured 53-segment bargraph meters, with a number of accurately modelled scales/responses to suit different applications and local preferences. Clear scale labels are provided for you to choose the scale displayed and the meter brightness can be adjusted from the front panel. A separate phase meter indicates channel correlation or phase

error conditions. On the rear panel, open-collector alarm outputs provide hardware indication of sustained underlevel, overlevel, phase errors and digital source lock.

Six illuminated pushbuttons provide access to a range of audio 'modifiers' – instant dimming of the volume, individual muting of each audio channel, stereo-to-mono conversion, phase inversion and Middle+Side transcoding. On the rear panel, logic-level inputs allow direct remote access to the DIM and MUTE functions.

The three-way loudspeaker system is fed via a DSP-based active crossover and a trio of highly efficient Class-D amplifiers. Careful attention to driver selection, materials and case design, plus active DSP equalisation, has ensured a flat response and outstanding reproduction from such a

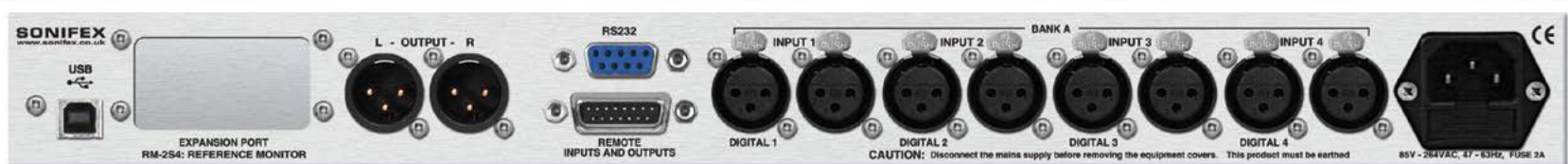





The RM-2S4 and RM-2S10 are both monitor bridges which accept stereo audio sources and have the same high specifications.

shallow unit. A protective limiter prevents damage to the loudspeakers under overload conditions and the front-panel headphone socket automatically mutes the internal loudspeakers when a plug is inserted.

A balance control allows you to alter the stereo imaging of the left and right channels.

A further five-band parametric equaliser can be accessed for room-equalisation purposes via Sonifex SCi Windows-based remote control software. Source selection, status monitoring and unit ID functions, plus firmware updates to add extra functionality,

are all accessible remotely via both USB and RS232 connections. The open control protocol also allows operation with terminal programs or customised applications.

An RM-HD1 HD/SD-SDI input expansion card can be added, allowing multiple AES groups embedded within an HD-SDI or SD-SDI signal to be de-embedded and monitored.

The RM-2S4 operates from global mains voltages (85-264V AC, 47-63Hz).

## RM-2S10 Reference Monitor, 2 LED Meters, 10 Stereo Analogue & 10 Stereo Digital Inputs

The RM-2S10 has the same extended feature set of the RM-2S4, monitoring stereo channels, but has 10 dedicated stereo analogue and 10 dedicated stereo AES/EBU digital audio sources, with sample rates up to 192kHz accepted.

The RM-2S10 uses 25 way D-type connectors for the audio inputs on the rear panel instead of Neutrik™ XLR connectors.

Sources are still selected via a front panel rotary encoder, but on the RM-2S10 the Source LEDs also act as signal present indicators.

In all other aspects the units have the same feature set.

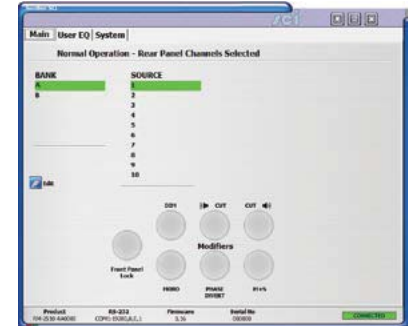

SCi Software Screen for RM-2S10.



## Technical Specification For RM-2S4 & RM-2S10

### Inputs

Audio Inputs (RM-2S4):	4 x stereo analogue or AES/EBU digital (autoselecting)
Audio Inputs (RM-2S10):	10 x stereo analogue, plus 10 x stereo AES/EBU digital
Max Level (0dB Input gain):	+18dBu (analogue)/0dBFS (digital)

CMRR:	>60dB typical
Input Impedance:	20kΩ (analogue) 110Ω (digital with termination switchable)
AES/EBU Sample Rate:	32 to 192kHz, converted internally to 48kHz
Input Gain:	0, +6, +12 or +18dB digital gain (switchable)
Selection:	Front panel rotary control with indicator LEDs

### Line Level Outputs

Audio Outputs:	1 x stereo analogue or AES/EBU digital (switchable)
Gain re Selected Input:	Unity or variable, following volume control (switchable)
Maximum Output Level:	+18dBu (analogue)/0dBFS (digital)
Output Impedance:	<50Ω (analogue)/110Ω (digital)
AES/EBU Sample Rate:	48kHz
Distortion:	<0.02% (1kHz, +8dBu output)
Noise:	-84dB RMS, unity gain ref +8dBu output
Frequency Response:	20Hz-20kHz +0/-0.5dB
Crosstalk 1kHz input:	Analogue I/O, ref 0dBu <-90dB
10kHz input:	<-85dB

### Audio Modifiers

Modifier Selection:	Illuminated front panel pushbuttons
---------------------	-------------------------------------

DIM:	Reduces speaker audio level by 10dB
CUT L & CUT R:	Mutes left/right speaker audio
MONO:	Combines left and right audio inputs
PHASE INVERT:	Inverts phase of right audio input
M+S:	Converts stereo input to Middle (sum) and Side (difference) signals

### User-Variable Equalisation

Type:	Parametric
Bands:	Five
Centre Frequency:	200Hz to 18kHz
Bandwidth:	0.25 to 2 octaves
Boost/Cut:	±12dB
Programming:	Via USB/serial control port

### Amplifier/Loudspeakers

Configuration:	Three-way with stereo mid/high-frequency drivers & mono low-frequency driver
Power Output:	2 x 5W (HF) + 20W (LF) with protective limiter
Crossover:	500Hz (3rd order Butterworth)
Distortion (HF Outputs):	< 0.05% (1kHz, 3W output)
Distortion (LF Output):	< 0.05% (100Hz, 6W output)
Noise:	More than 80dB below full output
Volume:	Mute to full volume via front panel rotary control
Balance Trim:	±6dB via front panel rotary control.
Peak Acoustic Level:	102dB SPL @ 2ft

### Level Metering

Number:	2 x 53-segment tri-colour LED bargraphs
---------	---

Characteristics:	Selectable by switch from: 1. Dual BBC PPM + standard VU 2. BBC PPM 3. EBU PPM 4. Nordic PPM 5. AES/EBU digital PPM 6. DIN PPM 7. Standard VU 8. Extended VU 9. German PPM
------------------	---

Ballistics:	According to selected characteristic
-------------	--------------------------------------

Line-Up Level:	According to selected characteristic
----------------	--------------------------------------

### Phase Metering

Type:	5-segment, indication at 0, 45, 90, 135 and 180 degrees
-------	---

### Remote Control

USB:	Slave device, 19200 baud
Serial:	RS232, 19200 baud, 3-wire connection
Alarm Outputs:	1. Audio underlevel/fail (latching) 2. Audio overlevel (latching) 3. Sustained phase error (latching) 4. AES/EBU input unlock (non-latching) Open-collector outputs rated at 30V, 50mA maximum Output low/conducting in normal condition (no alarm)

Control Inputs:	1. Mute audio 2. Dim audio 3. Alarm reset Pull-to-ground to activate inputs
-----------------	--

### Status Indicators

LIMIT:	Indicates loudspeaker protection limiter is active.
--------	---

CLIP:	Indicates internal digital clipping due to overlevel.
-------	---

LOCK:	Indicates lock achieved on selected digital input(s).
-------	---

OPT:	For future use.
------	-----------------

### Connectors

Audio Inputs (RM-2S4):	8 x XLR 3-pin female (balanced, may be unbalanced)
------------------------	--

Audio Inputs (RM-2S10):	3 x D-type 25-pin female (balanced, may be unbalanced)
-------------------------	--

Audio Outputs:	2 x XLR 3-pin male (balanced, may be unbalanced)
----------------	--

Headphones:	1/4" (6.35mm) A-gauge 3-pole stereo jack socket
-------------	---

USB:	Type B socket
------	---------------

Serial:	D-sub 9-pin female
---------	--------------------

Remote I/O:	D-sub 15-pin male
-------------	-------------------

Mains Input:	Filtered 3-pin IEC male, continuously rated 85 - 264VAC, 47 - 63Hz, fused, 60W peak, 30W average
--------------	--

Fuse Rating:	Anti-surge fuse 2A 20 x 5mm
--------------	-----------------------------

### Equipment Type

RM-2S4:	Reference Monitor, 2 LED meters, 4 stereo channel inputs
---------	--

RM-2S10:	Reference Monitor, 2 LED meters, 10 stereo channel inputs
----------	---

### Physical Specification

Dimensions (Raw):	48cm (W) x 30.5cm (D) x 4.4cm (H) (1U) 19" (W) x 12" (D) x 1.73" (H) (1U)
-------------------	--

Dimensions (Boxed):	58cm (W) x 52cm (D) x 14cm (H) 22.8" (W) x 20.5" (D) x 5.5" (H)
---------------------	--

Weight:	Nett: 4.5kg Gross: 6kg Nett: 10lb Gross: 13.2lb
---------	--

### Options

RM-HD1:	HD-SDI expansion card
---------	-----------------------



## RM-4C8 Reference Monitor, 4 LED Meters, 8 Channel Inputs & Dual Source Selectors



**Category:** Reference Monitors.

**Product Function:** Audible and visual metering of audio sources.

**Typical Applications:** Monitoring of multiple audio sources in an OB truck or engineering racks room.

**Features:** 3 speaker system, 5 band parametric EQ, phase meter, audio modifiers, multiple scales, analogue and digital inputs, superb sound, options for HD/SD-SDI de-embedding & Dolby® E decoding.

With 4 x bright high-resolution 26-segment meter displays and separate left and right source selectors, the RM-4C8 is ideal for monitoring audio channels in an SDI group, or groups of de-embedded AES/EBU channels.



SCI Software Screen for RM-4C8.

The RM-4C8 offers the same functionality as the RM-2S4 but with an additional source selector so that any of the 4 channels in the selected group, or bank, can be monitored independently on left and right speakers.

Also, 4 meters are provided so that every channel in the selected group, or bank, can be visually monitored. All audio channels in an HD-SDI signal can be monitored using the optional RM-HD1 card and Dolby encoded audio signals can be monitored using the RM-HDE1, RM-E1B or RM-E1X expansion cards.

The audio inputs on the RM-4C8 are auto-sensing, for digital AES/EBU using the left

input XLR, or both XLRs for analogue inputs. The inputs can be used in any combination of analogue or digital.

With full remote control via GPI, RS232 or USB, a 5 band parametric equaliser, 6 front panel modifier buttons and the ability to take the optional HD-SDI expansion cards, the RM-4C8 is a flexible and versatile monitoring solution.

The same high level of care has been taken in the design of the RM-4C8 as in the RM-2S4 to ensure that it's the best sounding 1U rack-mount audio monitor that you'll hear.

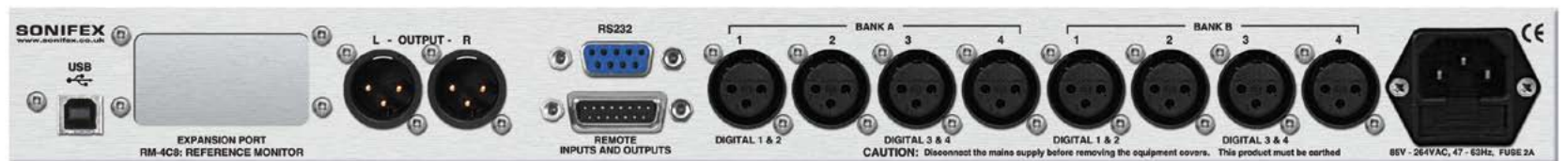

## Technical Specification For RM-4C8

### Audio Specification

Inputs	
Audio Inputs	8 analogue or AES/ EBU digital channels (autoselecting)
Max Level (0dB Input Gain):	+18dBu (analogue)/0dBFS (digital)
CMRR:	>60dB typical
Input Impedance:	20kΩ (analogue) 110Ω (digital with termination switchable)
AES/EBU Sample Rate:	32 to 192kHz, converted internally to 48kHz
Input Gain:	0, +6, +12 or +18dB digital gain (switchable)
Selection:	2 x Front panel rotary controls with indicator LEDs
Line Level Outputs	
Audio Outputs:	1 x stereo analogue or AES/EBU digital (switchable)
Gain re Selected Input:	Unity or variable, following volume control (switchable)
Maximum Output Level:	+18dBu (analogue)/0dBFS (digital)
Output Impedance:	<50Ω (analogue)/110Ω (digital)
AES/EBU Sample Rate:	48kHz
Distortion:	<0.02% (1kHz, +8dBu output)
Noise:	-84dB RMS, unity gain ref +8dBu output
Frequency Response:	20Hz-20kHz +0/-0.5dB
Crosstalk 1kHz input:	Analogue I/O, ref 0dB <-90dB
10kHz input:	<-85dB

### Audio Modifiers

Modifier Selection:	Illuminated front panel pushbuttons
DIM:	Reduces speaker audio level by 10dB
CUT L & CUT R:	Mutes left/right speaker audio
MONO:	Combines left and right audio inputs
PHASE INVERT:	Inverts phase of right audio input
M+S:	Converts stereo input to Middle (sum) and Side (difference) signals
User-Variable Equalisation	
Type:	Parametric
Bands:	Five
Centre Frequency:	200Hz to 18kHz
Bandwidth:	0.25 to 2 octaves
Boost/Cut:	±12dB
Programming:	Via USB/serial control port
Amplifier/Loudspeakers	
Configuration:	Three-way with stereo mid/high-frequency drivers & mono low-frequency driver
Power Output:	2 x 5W (HF) + 20W (LF) with protective limiter
Crossover:	500Hz (3rd order Butterworth)
Distortion (HF Outputs):	< 0.05% (1kHz, 3W output)
Distortion (LF Output):	< 0.05% (100Hz, 6W output)
Noise:	More than 80dB below full output
Volume:	Mute to full volume via front panel rotary control
Balance Trim:	±6dB via front panel rotary control
Peak Acoustic Level:	102dB SPL @ 2ft

### Level Metering

Number:	4 x 26-segment tri-colour LED bargraphs
Characteristics:	Selectable by switch from: <ol style="list-style-type: none"> <li>1. Dual BBC PPM + standard VU</li> <li>2. BBC PPM</li> <li>3. EBU PPM</li> <li>4. Nordic PPM</li> <li>5. AES/EBU digital PPM</li> <li>6. DIN PPM</li> <li>7. Standard VU</li> <li>8. Extended VU</li> <li>9. German PPM</li> </ol>
Ballistics:	According to selected characteristic
Line-Up Level:	According to selected characteristic
Phase Metering	
Type:	5-segment, indication at 0, 45, 90, 135 and 180 degrees
Remote Control	
USB:	Slave device, 19200 baud
Serial:	RS232, 19200 baud, 3-wire connection
Alarm Outputs:	<ol style="list-style-type: none"> <li>1. Audio underlevel/fail (latching)</li> <li>2. Audio overlevel (latching)</li> <li>3. Sustained phase error (latching)</li> <li>4. AES/EBU input unlock (non-latching)</li> </ol> Open-collector outputs rated at 30V, 50mA maximum Output low/conducting in normal condition (no alarm)
Control Inputs:	<ol style="list-style-type: none"> <li>1. Mute audio</li> <li>2. Dim audio</li> <li>3. Alarm reset</li> </ol> Pull-to-ground to activate inputs
Status Indicators	
LIMIT:	Indicates loudspeaker protection limiter is active.
CLIP:	Indicates internal digital clipping due to overlevel.
LOCK:	Indicates lock achieved on selected digital input(s).
OPT:	For future use.

### Connectors

Audio Inputs:	8 x XLR 3-pin female (balanced, may be unbalanced)
Audio Outputs:	2 x XLR 3-pin male (balanced, may be unbalanced)
Headphones:	1/4" (6.35mm) A-gauge 3-pole stereo jack socket
USB:	Type B socket
Serial:	D-sub 9-pin female
Remote I/O:	D-sub 15-pin male
Mains Input:	Filtered 3-pin IEC male, continuously rated 85 - 264VAC, 47 - 63Hz, fused, 60W peak, 30W average
Fuse Rating:	Anti-surge fuse 2A 20 x 5mm
Equipment Type	
RM-4C8:	Reference Monitor, 4 LED meters, 8 channel inputs & dual source selectors
Physical Specification	
Dimensions (Raw):	48cm (W) x 30.5cm (D) x 4.4cm (H) (1U) 19" (W) x 12" (D) x 1.73" (H) (1U)
Dimensions (Boxed):	58cm (W) x 52cm (D) x 14cm (H) 22.8" (W) x 20.5" (D) x 5.5" (H)
Weight:	Nett: 4.5kg    Gross: 6kg Nett: 10lb    Gross: 13.2lb
Options	
RM-HD1:	HD-SDI expansion card
RM-HDE1:	HD-SDI & Dolby® E expansion card
RM-E1X:	HD-SDI Dolby® E decoder XLR expansion card
RM-E1B:	HD-SDI & Dolby® E decoder BNC expansion card





## RM-4C8-HD1 Reference Monitor, 4 LED Meters, 8 Channel Inputs & Dual Source Selectors With RM-HD1 3G/HD/SD-SDI De-Embedder Card



**Category:** Reference Monitors.

**Product Function:** Allows the de-embedding of audio channels in a 3G/HD/SD-SDI stream.

**Typical Applications:** OB truck monitoring of incoming video feed from a sports ground. Post Production monitoring of HD-SD/SDI audio.

**Features:** Automatic 3G/HD/SD input detection, visual monitoring of all channels in a group, delay of an embedded group with PC configuration.

This is a version of the RM-4C8 with the RM-HD1 expansion card fitted. The expansion card allows the monitoring of embedded non-encoded linear PCM audio channels within a single link 3G/HD/SD-SDI video signal.

The RM-4C8 has individual channel selection for each speaker allowing individual channels in a 5.1 or multichannel mix to be selected for monitoring, e.g. the Centre or LFE channel can be isolated, or Left and Right Rear surround channels.

The expansion board can extract any selected AES/EBU audio group (4 channels) from the video signal and pass them to the main Reference Monitor unit for monitoring. Any group can be selected and can also be

optionally delayed by up to ~300ms by using the Sonifex SCi remote control software. All channels in the selected group can be monitored visually and 2 channels can be selected to be monitored on the speakers.

The input is auto-sensing for either SD, HD or single link 3G input formats and the extraction of embedded audio complies with SMPTE-272 (SD) and SMPTE-299 (HD/3G).

The SDI input is equalized, internally re-clocked and re-transmitted to provide a re-clocked output to pass to external equipment such as another reference monitor.

For the technical specification please refer to the RM-HD1 card itself.



SCi Software Screen for RM-4C8-HD1.





## RM-4C8-HDE1 Reference Monitor, 4 LED Meters, 8 Channel Inputs & Dual Source Selectors With De-Embedder & Dolby Decoder Card



**Category:** Reference Monitors.

**Product Function:** Allows the de-embedding of audio channels in a 3G/HD/SD-SDI stream and subsequent Dolby E decoding for audible & visual monitoring.

**Typical Applications:** For taking a satellite feed and monitoring HD-SDI and decoded Dolby E sources.

**Features:** Dolby metadata display on connected PC, 8 input metering on 4 meters, 3G/HD/SD-SDI de-embedding.

This version of the Reference Monitor is the RM-4C8 with the RM-HDE1 expansion card already fitted. So, it has all of the features of the RM-4C8 as standard together with the ability to de-embed audio from an HD-SDI stream and then decode a Dolby digital audio signal from that de-embedded audio.

The RM-HDE1 adds to the unit a 75ohm HD-SDI input and output on BNC connectors with the output acting as a loop-through of the input.

The monitor can take an HD-SDI input and de-embed audio from any selected audio group, with left and right speakers being able to monitor any 2 channels within that group. The 4 channels in a group are shown on the 4 bar-graph meters. If a Dolby E

or Dolby Digital input is detected on the selected input, the Channels (CHANS) button flashes to indicate that decoding is possible. Pressing the CHANS button displays the Dolby Digital 5.1 or Dolby E 8 channel signal, using the 4 bar-graph meters.

Each meter is split into 2 sections allowing you to view L, R, C, LFE, Ls, Rs for Dolby Digital and an additional Lt, Rt for Dolby E.

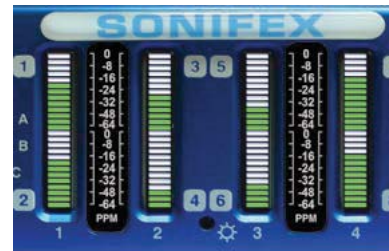

The Programmes (PROGS) button allows any Dolby programmes to be selected and monitored.

Full Dolby Metadata is available using the SCI remote control software. For a more detailed description of Dolby Decoding operation please refer to the Reference Monitor handbook.

With full remote control via GPI, RS232 or USB, a 5 band parametric equaliser, 6 front panel modifier buttons and the ability to take the optional HD-SDI expansion cards, the RM-4C8 is a flexible and versatile monitoring solution.



## RM-HD1 Reference Monitor 3G/HD/SD-SDI Expansion Card



**Category:** Reference Monitor Expansion Cards.

**Product Function:** Allows the de-embedding of audio channels in a 3G/HD/SD-SDI stream.

**Typical Applications:** OB truck monitoring of incoming video feed from a sports ground. Post Production monitoring of HD-SD/SDI audio.

**Features:** Automatic 3G/HD/SD input detection, visual monitoring of all channels in a group, delay of an embedded group with PC configuration.



This expansion board allows the monitoring of embedded non-encoded linear PCM audio channels within a single link 3G/HD/SD-SDI video signal.

The RM-HD1 card can be used with the RM-2S4, RM-2S10 and RM-4C8 monitors.

The expansion board can extract any selected AES/EBU audio group (4 channels) from the video signal and pass them to the

main Reference Monitor unit for monitoring. Any group can be selected and can also be optionally delayed by up to ~300ms by using the Sonifex SCi remote control software. All channels in the selected group can be monitored visually and 2 channels can be selected to be monitored on the speakers (for the RM-2S4 and RM-2S10, stereo pairs are selected; the RM-4C8 allows any 2 channels to be monitored). The input is auto-sensing for either SD, HD or single link 3G input formats and the extraction of embedded audio complies with SMPTE-272 (SD) and SMPTE-299 (HD/3G).

The SDI input is equalized, internally re-clocked and re-transmitted to provide a re-clocked output to pass to external equipment such as another reference monitor.

### Technical Specification For RM-HD1

SDI Specification	
SDI Input:	1 x BNC, 3G/HD/SD-SDI
SDI Outputs:	1 x BNC, 3G/HD/SD-SDI, Re-clocked
Impedance:	75Ω
Output Alignment Jitter:	<0.2UI
Output Level:	800mV +/- 10%
Return Loss:	<15dB at 1500MHz
SDI Supported Standards:	270Mbps, SMPTE-259M-C (SD) 1.485 or 1.4835Gbps, SMPTE-292M (HD) 2.97 or 2.967Gbps, SMPTE-424M (3G)
Supported Video Formats:	525/59.94 (SMPTE-125M) 625/50 (ITU-R BT.656) 720p/23.98, 24, 25, 29.97, 30, 50, 59.94, 60 (SMPTE-296M) 1035i/59.94, 60 (SMPTE-260M) 1080i/50, 59.94, 60 (SMPTE-274M) 1080p/23.98, 24, 25, 50, 59.94, 60 (SMPTE-274M) 1080pSF/23.98, 24, 25, 29.97, 30 (RP-211) 1080i/50 (SMPTE-295M) 1080p/50 (SMPTE-295M)
Embedded Audio:	48kHz, synchronous (HD asynchronous) SMPTE-272M-ABC SMPTE-299M

Equipment Type	
RM-HD1:	3G/HD/SD-SDI expansion card
Physical Specification	
Dimensions (Raw):	15cm (W) x 11.5cm (D) x 3.1cm (H) 5.9" (W) x 4.5" (D*) x 1.2" (H) (1U)
Dimensions (Boxed):	22.9cm (W) x 12.7cm (D) x 7.6cm (H) 9.0" (W) x 5.0" (D) x 3.0" (H)
Weight (RM-HD1):	Nett: 0.13kg Gross: 0.4kg Nett: 0.3lb Gross: 0.9lb

		Reference Monitor		
		RM-2S4	RM-2S10	RM-4C8
Expansion Card	RM-HD1	✓	✓	✓
	RM-HDE1	✗	✗	✓
	RM-E1X	✗	✗	✓
	RM-E1B	✗	✗	✓

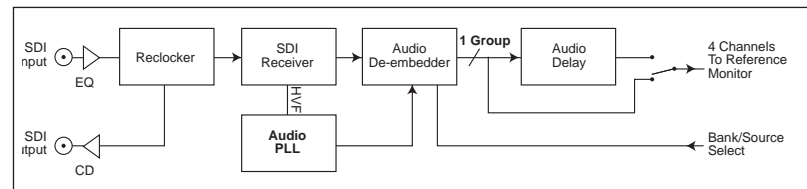



## RM-HDE1 Reference Monitor HD-SDI & Dolby® E & Dolby® Digital Expansion Card



**Category:** Reference Monitor Expansion Cards.

**Product Function:** Allows the de-embedding of audio channels in a 3G/HD/SD-SDI stream and subsequent Dolby E decoding.

**Typical Applications:** For taking a satellite feed and monitoring HD-SDI and decoded Dolby E sources. Post Production monitoring of HD-SD/SDI audio.

**Features:** Dolby metadata display on connected PC, 8 input metering on 4 meters, 3G/HD/SD-SDI de-embedding and monitoring



This expansion board allows the monitoring of embedded audio channels within a single link 3G/HD/SD-SDI video signal. The embedded audio can be either non-encoded linear PCM, Dolby® E or Dolby® Digital. Please note that the RM-HDE1 card is for use with the RM-4C8 unit only.

The expansion board can extract any selected AES/EBU audio group (4 channels) from the video signal and pass them to the main Reference Monitor unit for monitoring. Any group can be selected. All channels in the selected group can be monitored

visually and any 2 channels can be selected to be monitored on the speakers. If a Dolby E or Dolby Digital input is detected on the selected channel, the Channels (CHANS) button flashes to indicate that decoding is possible. Pressing the CHANS button displays the Dolby Digital 5.1 or Dolby E 8 channel signal, using the 4 bar-graph meters. Each meter is split into 2 sections, top and bottom, allowing you to monitor all 8 channels coming from the Decoder.

Full Dolby Metadata is available using the Sci remote control software. For a more detailed description of Dolby Decoding operation please refer to the handbook.

The input is auto-sensing for either SD, HD or single link 3G input formats and the extraction of embedded audio complies with SMPTE-272 (SD) and SMPTE-299 (HD/3G). The SDI input is equalized,

internally re-clocked and re-transmitted to provide a re-clocked output to pass to external equipment such as another reference monitor.

### Technical Specification For RM-HDE1

SDI Specification	
SDI Input:	1 x BNC, 3G/HD/SD-SDI
SDI Output:	1 x BNC, 3G/HD/SD-SDI, Re-clocked
Impedance:	75Ω
Output Alignment Jitter:	<0.2UI
Output Level:	800mV +/- 10%
Return Loss:	<15dB at 1500MHz
SDI Supported Standards:	270Mbps, SMPTE-259M-C (SD) 1.485 or 1.4835Gbps, SMPTE-292M (HD) 2.97 or 2.967Gbps, SMPTE-424M (3G)
Supported Video Formats:	525/59.94 (SMPTE-125M) 625/50 (ITU-R BT.656) 720p/23.98, 24, 25, 29.97, 30, 50, 59.94, 60 (SMPTE-296M) 1035i/59.94, 60 (SMPTE-260M) 1080i/50, 59.94, 60 (SMPTE-274M) 1080p/23.98, 24, 25, 50, 59.94, 60 (SMPTE-274M) 1080psF/23.98, 24, 25, 29.97, 30 (RP-211) 1080i/50 (SMPTE-295M) 1080p/50 (SMPTE-295M)
Embedded Audio:	48kHz, synchronous (HD asynchronous) SMPTE-272M-ABC & SMPTE-299M
Equipment Type	
RM-HDE1:	HD-SDI & Dolby® E expansion card
Physical Specification	
Dimensions (Raw):	15cm (W) x 11.5cm (D) x 3.1cm (H) 5.9" (W) x 4.5" (D*) x 1.2" (H) (1U)
Dimensions (Boxed):	22.9cm (W) x 12.7cm (D) x 7.6cm (H) 9.0" (W) x 5.0" (D) x 3.0" (H)
Weight (RM-HDE1):	Nett: 0.15kg Gross: 0.4kg Nett: 0.3lb Gross: 0.9lb

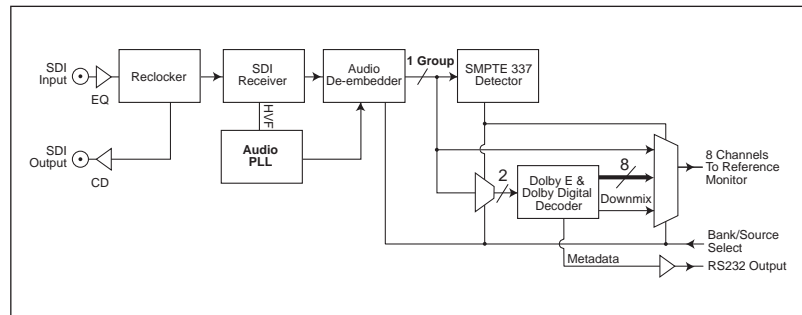





# RM-E1X Reference Monitor Dolby E & Dolby® Digital Decoder XLR AES Expansion Card RM-E1B Reference Monitor Dolby E & Dolby® Digital Decoder BNC Expansion Card



**Category:** Reference Monitor Expansion Cards.

**Product Function:** Allow Dolby E decoding from an AES/EBU audio input

**Typical Applications:** For monitoring a Dolby E or D audio source.

**Features:** Dolby metadata display on connected PC, 8 input metering on 4 meters, Dolby E decoding & monitoring.



RM-E1X Expansion Card.

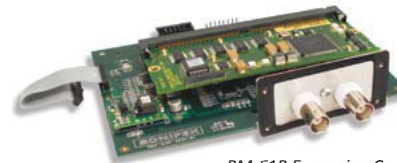

RM-E1B Expansion Card.

These expansion boards for the Reference Monitor RM-4C8 allow the monitoring of a digital audio stream containing either Linear PCM or Dolby\* encoded audio.

The RM-E1X has 2 x XLR inputs to accept AES/EBU level inputs and the RM-E1B has 2 x BNC connectors for S/PDIF level inputs.

Dolby data is decoded and passed to the Reference Monitor as either a stereo down mix or the full complement of individual channels. If the signal is standard Linear

PCM, then this audio data is simply passed straight through.

The input is re-transmitted with minimal delay, to allow connection to other equipment.

*\* Dolby and the double-D symbol are registered trademarks of Dolby Laboratories.*

### Technical Specification For RM-E1X and RM-E1B

**Audio Specification**

AES Input/ Output:	110Ω transformer coupled balanced I/O (RM-E1X)
S/PDIF Input/ Output:	75Ω transformer coupled unbalanced I/O (RM-E1B)
Sample Rates:	32 - 48 kHz
Audio Formats:	Linear PCM Dolby E (16, 20 and 24 bit) Dolby Digital (16 and 32 bit)

**Connectors**

AES Input:	1 x XLR 3 pin socket (RM-E1X)
AES Output:	1 x XLR 3 pin plug (RM-E1X)
S/PDIF Input:	1 x BNC (RM-E1B)
S/PDIF Output:	1 x BNC (RM-E1B)

**Equipment Type**

RM-E1X:	Dolby® E Decoder XLR expansion card
RM-E1B:	Dolby® E Decoder BNC expansion card

**Physical Specification**

Dimensions (Raw):	15cm (W) x 11.5cm (D) x 3.1cm (H) 5.9" (W) x 4.5" (D) x 1.2" (H) (1U)
Dimensions (Boxed):	22.9cm (W) x 12.7cm (D) x 7.6cm (H) 9.0" (W) x 5.0" (D) x 3.0" (H)
Weight (RM-E1X/B):	Nett: 0.13kg Gross: 0.4kg Nett: 0.3lb Gross: 0.9lb

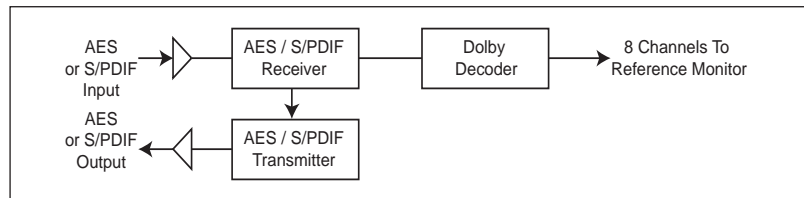

*\* Dolby and the double-D symbol are registered trademarks of Dolby Laboratories.*



## RM-CA2 Confidence Monitor, 2 LED Meters & 2 Analogue Stereo Inputs



**Category:** Confidence Monitors.

**Product Function:** Audible & visual monitoring of analogue audio inputs.

**Typical Applications:** Radio station engineering racks-room for monitoring news feeds.

**Features:**

- Anti-vibration steel case.
- Sealed lid with foam cut-outs to dampen lid.

- Multi-point screw fixings ensure lid rigidity.
- Rear connector ports sealed with foam.
- Glue used on components which could move, or vibrate.
- Accurate 3-way speaker system.
- Two mid/high frequency speakers provide excellent stereo imaging.
- Separately driven, forward facing, dual magnet, mono bass driver.
- Custom-moulded, profiled, HF enclosures minimise standing waves.
- Acoustic damping in the HF enclosures reduces colouration.
- Separate, sealed, infinite-baffle enclosure for each driver.
- Separate, highly efficient class-D switching amplifier for each speaker.
- Short, even cable lengths to and from the speaker enclosures to reduce any potential microphonic induction.
- DSP based design allows better audio performance to be realised.
- Active crossover provides perfect separation between mid-range and bass sounds.
- A universal power supply ensures global voltage operation without adjustment.
- Optional DC power input.





**Using the same outstanding speaker system as the Reference Monitor range, the confidence monitors offer a superb sound with simpler controls.**

The confidence monitors have been designed to give the best possible performance at a reduced price.

The RM-CA2 is a 1U rack-mount unit offering quality loudspeaker monitoring and 2 channel metering of two stereo analogue audio sources. Input 1 has stereo balanced Neutrik™ XLRs and Input 2 has both stereo balanced Neutrik™ XLRs and stereo unbalanced RCA phono connectors. The balanced analogue inputs can be wired unbalanced if required.

Sources are selected via a front panel push-button switch, with clear LED indication of the current source.

A rear panel DIPswitch setting allows the unit to monitor either:

- Stereo signals, with the two front panel control knobs acting as stereo volume and balance control, to alter the stereo imaging of the left and right channels, or
- Dual mono signals, with the two front panel control knobs acting as left and right volume controls.

There is a front panel headphone socket which responds to the volume controls and the headphone socket automatically mutes the internal loudspeakers when a plug is inserted.

A pair of line-level analogue audio outputs follow the selected source at the selected level, or optionally at 10dB lower (if using the unbalanced input), set via rear-panel DIPswitch.

The level of the chosen source is shown on an 8 segment LED bar-graph display with PPM and VU scales indicated. The bar-graph can optionally be lowered by 10dB (if using the unbalanced input), set via rear-panel DIPswitch.

A single phase meter LED indicates channel correlation or phase error conditions.

The three-way loudspeaker system is fed via a DSP-based active crossover and a trio of highly efficient Class-D amplifiers. Careful attention to driver selection, materials and

case design, plus active DSP equalisation, has ensured a flat response and outstanding reproduction from such a shallow unit. A protective limiter prevents damage to the loudspeakers under overload conditions

The RM-CA2 operates from global mains voltages (85-264V AC, 47-63Hz) without adjustment and can optionally be ordered with a DC 9V to 36V input instead of the AC input.



## RM-CAD8 Confidence Monitor, 2 LED Meters, 2 Analogue & 6 Digital Stereo Inputs



**Category:** Confidence Monitors.

**Product Function:** Audible & visual monitoring of analogue audio inputs.

**Typical Applications:** Radio station engineering racks-room for monitoring news feeds.

**Features:** The RB-CAD8 has the same feature set as the RB-CA2 with the addition of AES/EBU, S/PDIF and Toslink digital audio inputs.



The RM-CAD8 has all the features of the RM-CA2 together with the ability to select from an additional 6 stereo digital inputs.

As well as the 2 stereo analogue inputs there are also:

- 4 x stereo AES/EBU balanced inputs on XLR 3 pin female.
- 1 x stereo S/PDIF unbalanced input on RCA phono female.
- 1 x stereo Toslink unbalanced input on an optical connector.

The source select button illuminates to indicate synchronisation lock to the incoming digital source.

Sample rate converters on the digital inputs allow sources of different sample rates to be connected and monitored, between 32kHz and 96kHz.

All other features of the unit are identical to the RM-CA2.





### Technical Specification For RM-CA2 & RM-CAD8

#### Audio Specification

<b>Inputs</b>	
Audio Inputs (RM-CA2):	2 x stereo analogue (1 x XLR balanced, 1 x XLR balanced or RCA phono unbal)
Audio Inputs (RM-CAD8):	2 x stereo analogue (1 x XLR balanced, 1 x XLR balanced or RCA phono unbal) 4 x stereo XLR balanced AES/EBU digital 1 x stereo RCA phono S/PDIF digital 1 x stereo optical TOSLink digital
Max Level (0dB Input Gain):	+18dBu (analogue)/0dBFS (digital)
CMRR:	>60dB typical
Analogue Input Impedances:	XLR: >20kΩ balanced bridging RCA: >10kΩ unbalanced
Digital Input Impedances:	(RM-CAD8 only): 110Ω ±20% AES/EBU balanced I/O 75Ω ±5% S/PDIF unbalanced I/O 75Ω ±5% TOSlink unbalanced I/O
AES/EBU Sample Rate:	32 to 96kHz, converted internally to 48kHz
<b>(RM-CAD8 only):</b>	
Input Gain:	+10dB on unbalanced input
Selection:	Front panel push button with indicator LEDs
<b>Line Level Outputs</b>	

Audio Outputs:	1 x stereo analogue
Gain re Selected Input:	Unity or -10dB (switchable)
Maximum Output Level:	+18dB
Output Impedance:	<50Ω
Distortion:	<0.02% (1kHz, +8dBu output)
Noise:	-95dB RMS, unity gain ref +8dBu output
Frequency Response:	20Hz-20kHz +0/-0.5dB
Crosstalk 1kHz input:	Analogue I/O, ref 0dBu
10kHz input:	<-85dB
<b>Amplifier/Loudspeakers</b>	
Configuration:	Three-way with stereo mid/high-frequency drivers & mono low-frequency driver
Power Output:	2 x 7W (HF) + 15W (LF) with protective limiter
Crossover:	250Hz (24dB/octave, Linkwitz-Riley)
Distortion (HF Outputs):	< 0.1% (1kHz, 3W output)

Distortion (LF Output):	< 0.1% (100Hz, 6W output)
Noise:	More than 102dB below full output
Volume:	Mute to full volume via front panel rotary control
Balance Trim:	±6dB via front panel rotary control.
Peak Acoustic Level:	98dB SPL @ 2ft
<b>Level &amp; Phase Metering</b>	
Number:	2 x 8-segment LED bargraphs
Line-Up Level:	0dB on scale can be set to 0dB or -10dB via rear panel DIPswitch
Phase Meter:	Single LED indication showing average
<b>Connectors</b>	
Audio Inputs (RM-CA2):	4 x XLR 3-pin female balanced 2 x RCA female phono unbalanced
Audio Inputs (RM-CAD8):	4 x XLR 3-pin female analogue 2 x RCA phono analogue 4 x XLR 3-pin female AES/EBU digital 1 x RCA phono female S/PDIF digital 1 x optical TOSLink digital
Audio Outputs:	2 x XLR 3-pin male (balanced, may be unbalanced)

Headphones:	1/4" (6.35mm) A-gauge 3-pole stereo jack socket
Mains Input:	Filtered 3-pin IEC male, continuously rated 85 - 264VAC, 47 - 63Hz, fused, 60W peak, 30W average
Fuse Rating:	Anti-surge fuse 2A 20 x 5mm
<b>Equipment Type</b>	
RM-CA2:	Confidence Monitor, 2 LED meters, 2 analogue stereo inputs
RM-CA2-DC:	Confidence Monitor, 2 LED meters, 2 analogue stereo inputs, DC supply
RM-CAD8:	Confidence Monitor, 2 LED meters, 2 analogue & 6 digital stereo inputs
RM-CAD8-DC:	Confidence Monitor, 2 LED meters, 2 analogue & 6 digital stereo inputs, DC supply
<b>Physical Specification</b>	
Dimensions (Raw):	48cm (W) x 27cm (D) x 4.4cm (H) (1U) 19" (W) x 12" (D) x 1.73" (H) (1U)
Dimensions (Boxed):	57cm (W) x 52cm (D) x 15cm (H) 22.4" (W) x 20.5" (D) x 5.9" (H)
Weight:	Nett: 4.5kg Gross: 6kg Nett: 10lb Gross: 13.2lb



## Reference Monitor Meters

The Reference Monitor Meters are a range of freestanding and 1U rack-mount precision meters offering accurate, high resolution metering of between 1 and 4 stereo audio sources.

Each stereo source is auto-switching between either analogue or digital AES/EBU format with sample rates up to 192kHz accepted.

The level of each stereo source is displayed on a pair of bright, multi-coloured bargraph meters, with a large choice of accurately modelled scales/responses to suit different applications and local preferences. Separate 5 LED phase meters indicate channel correlation or phase error conditions, and additional LEDs show digital input lock and audio level alarm status.

On the rear panel, open-collector alarm outputs provide hardware indication of audio under-level or silence, audio over-level, sustained phase errors above 90 degrees and digital source lock.

Status monitoring and unit ID functions, plus firmware updates to add extra functionality, are all accessible remotely via a RS232 connection in conjunction with Sonifex SCI software.

All Reference Monitor Meters operate from global mains voltages (85-264V AC, 47-63Hz) without adjustment.

There are eight Reference Monitor Meters:

- RM-M1F53 1 Stereo 53-Segment Meter, Free-Standing
- RM-M1R53 1 Stereo 53-Segment Meter, Rack-Mount
- RM-M2F53 2 Stereo 53-Segment Meters, Free-Standing
- RM-M2R53 2 Stereo 53-Segment Meters, Rack-Mount
- RM-M4R53 4 Stereo 53-Segment Meters, Rack-Mount
- RM-M1F106 1 Stereo 106-Segment Meter, Free-Standing
- RM-M1R106 1 Stereo 106-Segment Meter, Rack-Mount
- RM-M2R106 2 Stereo 106-Segment Meters, Rack-Mount

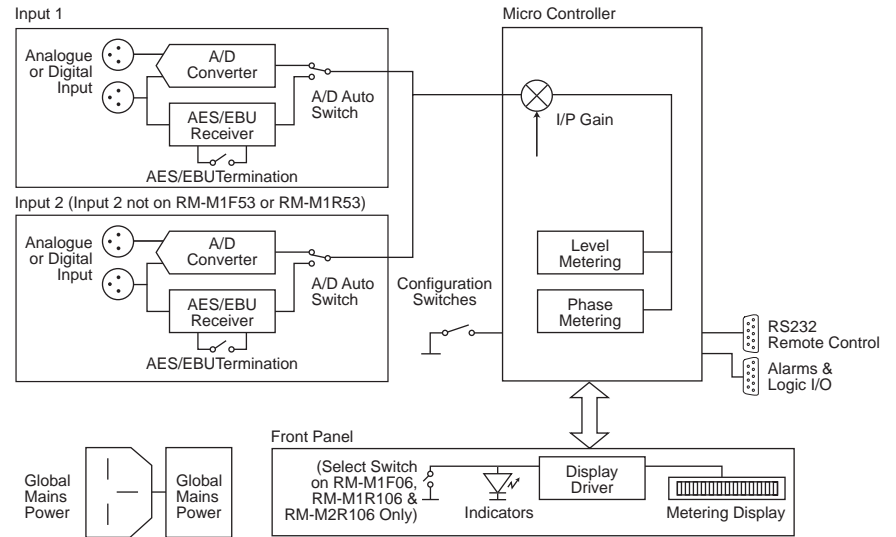

Reference Monitor Meters Block Diagram.



## RM-M1F53 1 Stereo 53-Segment Meter, Free-Standing



**Category:** Reference Monitor Meters.

**Product Function:** Visual monitoring of analogue and digital audio inputs.

**Typical Applications:** Radio station engineering racks-room for monitoring news feeds and audio sources.

**Features:**

- Bright, accurate precision LED meters.
- Auto-switching analogue or digital audio inputs.
- 9 meter scales and ballistics types
- Phase meter.
- Alarm GPOs for under/over level.
- RS232 connection for PC updates and control.
- Desktop or rack-mount formats.

The RM-M1F53 is a free-standing, single stereo channel meter with bright, multi-coloured 53-segment bargraph meters and all the features listed in the summary.



## RM-M1R53 1 Stereo 53-Segment Meter, Rack-Mount



The RM-M1R53 is a 1U rack-mount version of the RM-M1F53.

### Available Scales/Ballistics For All Meters

There are nine scales available with accurately modelled ballistics. Each stereo meter pair can have a different scale, set via a DIPswitch on the rear panel. A complete set of overlays are provided per stereo meter so that you can define the scale(s) that you need:

1. Dual BBC PPM + standard VU
2. BBC PPM IEC60268-10 11a
3. EBU PPM IEC60268-10 11b
4. Nordic PPM IEC60268-10 1
5. AES/EBU IEC60268-18 digital PPM
6. DIN PPM DIN45406
7. Standard VU IEC60268-17
8. Extended VU IEC60268-17
9. German PPM



SCI Software Screen for RM-M1F53 .



## RM-M2F53 2 Stereo 53-Segment Meters, Free-Standing

The RM-M2F53 is a free-standing, twin stereo channel meter with bright, multi-coloured 53-segment bargraph meters and all the features listed in the summary.



## RM-M2R53 2 Stereo 53-Segment Meters, Rack-Mount

The RM-M2R53 is a 1U rack-mount version of the RM-M2F53.



## RM-M4R53 4 Stereo 53-Segment Meters, Rack-Mount

The RM-M4R53 is a 1U rack-mount which combines 2 x RM-M2R53 units, providing 4 stereo channel monitoring.







## RM-M1F106 1 Stereo 106-Segment Meter, Free-Standing



**Category:** Reference Monitor Meters.  
**Product Function:** Visual monitoring of analogue and digital audio inputs.  
**Typical Applications:** Radio station engineering racks-room for monitoring news feeds and audio sources.  
**Features:** As per 53 segment meters with the addition of a stereo source select button.



The RM-M1F106 is a single stereo channel free-standing meter but with 2 stereo inputs and a front panel source selector.

This unit has a pair of multi-coloured 106-segment bargraph meters for greater display accuracy. A front panel mounted push-button selects the input source to be monitored, from either of the 2 auto-switching analogue or digital AES/EBU stereo inputs, or from a mono mix of each channel, with channel 1 shown on the left meter and channel 2 shown on the right meter. All other functionality is listed in the summary.

## RM-M1R106 1 Stereo 106-Segment Meter, Rack-Mount



The RM-M1R106 is a 1U rack-mount version of the RM-M1F106.

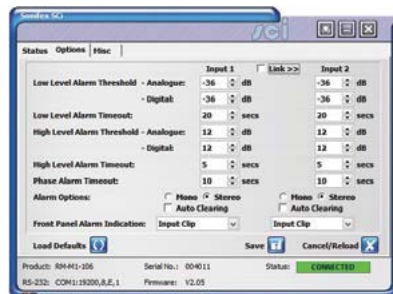

Sci Software Screen for RM-M1F106.



## RM-M2R106 2 Stereo 106-Segment Meters, Rack-Mount

A dual rack mount version, the RM-M2R106, combines 2 x RM-M1R106 units, giving 4 stereo channel monitoring.



### Technical Specification For Reference Monitor Meters

Audio Specification	Level Metering
<b>Inputs</b> Audio Inputs: 1 x stereo analogue or AES/EBU digital (auto-selecting) (RM-M1F53 & RM-M1R53) 2 x stereo analogue or AES/EBU digital (auto-selecting) (RM-M2F53, RM-M2R53, RM-M1F106 & RM-M1R106) 4 x stereo analogue or AES/EBU digital (auto-selecting) (RM-M4R53 & RM-M2R106)	<b>Number:</b> 1 x 53-segment tri-colour LED bargraphs (RM-M1F53 & RM-M1R53) 2 x 53-segment tri-colour LED bargraphs (RM-M2F53, RM-M2R53) 4 x 53-segment tri-colour LED bargraphs (RM-M4R53) 1 x 106-segment tri-colour LED bargraphs (RM-M1F106, RM-M1R106) 2 x 106-segment tri-colour LED bargraphs (RM-M2R106)
<b>Max Level (0dB Input Gain):</b> +18dBu (analogue)/0dBFS digital	<b>Characteristics:</b> Selectable by DIPswitch from: 1. Dual BBC PPM + standard VU 2. BBC PPM IEC60268-10 11a 3. EBU PPM IEC60268-10 11b 4. Nordic PPM IEC60268-10 1 5. AES/EBU digital PPM IEC60268-18 6. DIN PPM DIN45406 7. Standard VU IEC60268-17 8. Extended VU IEC60268-17 9. German
<b>CMRR:</b> >60dB typical	<b>Ballistics:</b> According to selected characteristic <b>Line-Up Level:</b> According to selected characteristic
<b>Input Impedance:</b> 20kΩ (analogue) 110Ω (digital with termination switchable via DIPswitch)	<b>Phase Metering</b> <b>Type:</b> 5-segment, indication at 0, 45, 90, 135 and 180 degrees, 1 per stereo meter
<b>AES/EBU Sample Rate:</b> 32 to 192kHz, converted internally to 48kHz	
<b>Input Gain:</b> 0, +6, +12 or +18dB digital gain (switchable via DIPswitch)	
<b>Selection:</b> Front panel illuminated push switch button (RM-M1F106, RM-M1R106 & RM-M2R106)	

Remote Control	Physical Specification
<b>Serial:</b> RS232, 19200 baud, 3-wire connection	<b>Dimensions (Raw):</b> RM-M1F53, RM-M2F53 & RM-M1F106 21.8cm (W) x 14.8cm (D) x 4.4cm (H) 8.6" (W) x 5.8" (D) x 1.73" (H)
<b>Alarm Outputs:</b> (1-4 single input units, 1-8 twin units) <ol style="list-style-type: none"> <li>1. Audio input 1 under-level/fail (latching)</li> <li>2. Audio input 1 over-level (latching)</li> <li>3. Audio input 1 sustained phase error above 90 degrees (latching)</li> <li>4. AES/EBU input 1 unlock (non-latching)</li> <li>5. Audio input 2 under-level/fail (latching)</li> <li>6. Audio input 2 over-level (latching)</li> <li>7. Audio input 2 sustained phase error above 90 degrees (latching)</li> <li>8. AES/EBU input 2 unlock (non-latching)</li> </ol> Open-collector outputs rated at 30V, 50mA maximum Output low/conducting in normal condition (no alarm)	<b>Dimensions (Boxed):</b> RM-M1R53, RM-M2R53, RM-M4R53 & RM-M1R106 & RM-M2R106 34.5cm (W) x 27cm (D) x 7cm (H) 13.6" (W) x 10.6" (D) x 2.75" (H)
<b>Control Inputs:</b> (1 single input units, 2 twin units) <ol style="list-style-type: none"> <li>1. Input 1 Alarm reset</li> <li>2. Input 2 Alarm reset</li> </ol> Pull-to-ground to activate inputs	<b>Weight:</b> RM-M1F53 & RM-M1R53 Nett: 1.3kg Gross: 2.0kg Nett: 2.9lb Gross: 4.4lb
<b>Status Indicators</b> <b>AES Lock:</b> Indicates lock achieved on digital input <b>Level Alarm:</b> Indicates audio over-level	<b>Weight:</b> RM-M2F53 & RM-M1F106 Nett: 1.4kg Gross: 2.1kg Nett: 3.1lb Gross: 4.6lb
	<b>Weight:</b> RM-M2R53 & RM-M1R106 Nett: 1.45kg Gross: 2.15kg Nett: 3.2lb Gross: 4.7lb
	<b>Weight:</b> RM-M4R53 & RM-M2R106 Nett: 2.8kg Gross: 3.5kg Nett: 6.2lb Gross: 7.7lb

Connectors	Equipment Type
<b>Audio Inputs:</b> (All balanced, but may be wired unbal) 2 x XLR 3-pin female (RM-M1F53 & RM-M1R53) 4 x XLR 3-pin female (RM-M2F53, RM-M2R53, RM-M1F106 & RM-M1R106) 8 x XLR 3-pin female (RM-M4R53 & RM-M2R106)	RM-M1F53 1 stereo 53-segment meter, free-standing RM-M1R53 1 stereo 53-segment meter, rack-mount RM-M2F53 2 stereo 53-segment meters, free-standing RM-M2R53 2 stereo 53-segment meters, rack-mount RM-M4R53 4 stereo 53-segment meters, rack-mount RM-M1F106 1 stereo 106-segment meter, free-standing RM-M1R106 1 stereo 106-segment meter, rack-mount RM-M2R106 2 stereo 106-segment meters, rack-mount
<b>Serial:</b> D-sub 9-pin female	
<b>Remote I/O:</b> D-sub 15-pin female	
<b>Mains Input:</b> Filtered 3-pin IEC male, continuously rated 85 – 264VAC, 47 – 63Hz, fused 1A, 30W peak, 15W average	



## Reference Monitor Controllers

The Reference Monitor Controllers are a range of 1U rack-mount audio production control units, for providing source selection, volume, DIM and CUT controls for external analogue monitors, together with light controls for the Sonifex SignalLED range of studio signs, or similar.

Each of the products has a light control section. This section has 3 buttons: Transmit (TX), STANDBY and Rehearse (REH). The TX and REH buttons control opto-isolated outputs on the rear panel remote connector, and these provide a direct control interface to the Sonifex SignalLED illuminated studio sign, allowing twin signs to be controlled individually.

The Standby button initiates a 2 minute countdown where the TX and REH buttons and their associated remote outputs flash alternately. After the 2 minutes has elapsed, the TX output remains on.

The remote port also has open-collector tally outputs for Transmit (TX), Rehearse (REH), as well as remote input control for the audio controls DIM and CUT, and the light controls TX, Standby and REH. There is also a +12 Volt source at 200mA maximum.

The TX, STANDBY and REH buttons can optionally be replaced if you want to use different buttons for other applications.

There are four Monitor Controller products:

- RM-MC1L Monitor Controller, Single Stereo Input & Output With Light Control
- RM-MC4L Monitor Controller, 4 Stereo Inputs, 1 Output With Light Control
- RM-MC51L Monitor Controller, 5.1 Stereo Inputs & Outputs With Light Control
- RM-MCL Monitor Light Controller, 3 Button, TX-STANDBY-REH





## RM-MC1L Monitor Controller, Single Stereo Input & Output With Light Control



**Category:** Reference Monitor Controllers.

**Product Function:** Volume control, dim and mute control of powered speakers with Rehearse/Transmit light control.

**Typical Applications:** Production control room, live studio broadcasts, recording studios.

**Features:** Separate remoteable DIM & CUT buttons, tally outputs for REH and TX, DIM level control.

The RM-MC1L is a stereo unit with a single stereo balanced analogue input and output on XLRs. Useful in a production environment, the unit allows you to control the audio level to external monitors and to DIM the audio, or CUT it completely with simple front panel controls, or remote external inputs.

It has a master volume control that adjusts the attenuation on the output channels from 0dB down to -86dB. A CUT control mutes the audio outputs when enabled, whilst a rear panel DIM control attenuates the audio output channels by a pre-set amount from -2dB to -23dB.

All of the buttons on the front panel are illuminated by LEDs and the brightness can be changed to better suit the environment in which the unit is used.

The remote port allows control of the DIM and CUT buttons and has tally outputs for TX (transmit) and REH (rehearse).





## RM-MC4L Monitor Controller, 4 Stereo Inputs, 1 Stereo Output With Light Control



**Category:** Reference Monitor Controllers.

**Product Function:** Volume control, dim and mute control of powered speakers with a 4 source selector and Rehearse/ Transmit light control.

**Typical Applications:** Production control room, live studio broadcasts, recording studios.

**Features:** 4 input source selector, separate remoteable DIM & CUT buttons, tally outputs for REH and TX, DIM level control.

The RM-MC4L has four stereo balanced analogue inputs with a single stereo balanced output, all using XLR connectors.

Four illuminated front panel buttons allow you to simply select the source required at the output.

The RM-MC4L has the same master volume control, CUT, DIM and light control functions and adjustments as the RM-MC1L unit.



## RM-MC51L Monitor Controller, 5.1 Stereo Inputs & Outputs With Light Control



**Category:** Reference Monitor Controllers.

**Product Function:** Volume control, dim and mute control of surround sound powered speakers with Rehearse/ Transmit light control.

**Typical Applications:** 5.1 speaker system level control, production control rooms, live studio broadcasts, recording studios.

**Features:** Separate remoteable DIM & CUT buttons, tally outputs for REH and TX, DIM level control.

The RM-MC51L is a controller for surround sound applications with 6 balanced analogue inputs and 6 balanced analogue outputs all on XLR connectors.

It is used in situations where you need to adjust the volume, or CUT, or DIM all of the speakers in a 5.1 surround system. Alternatively, the unit can be used as a global volume control for 6 analogue outputs.

The RM-MC51L has the same master volume control, CUT, DIM and light control functions and adjustments as the RM-MC1L unit.



## RM-MCL Monitor Light Controller, 3 Button, TX-STANDBY-REH



The RM-MCL is a simple light controller for controlling a TX - STANDBY - REH light system in a production studio, as detailed in the introduction. It has no audio inputs or outputs.

### Specification For RM-MC1L, RM-MC4L, RM-MC51L & RM-MCL Reference Monitor Controllers

Audio Specification		Front Panel Operation Controls		Audio Outputs		Equipment Type	
Input Impedance:	>20kΩ	Light Control (All units):	Transmit (TX), Standby & Rehearse (REH) illuminated buttons	RM-MC1L & RM-MC4L:	2 x XLR 3-pin male (balanced)	RM-MC1L:	Monitor controller, single stereo input & output with light control
Maximum Input Level:	+25dBu	Channel Select (RM-MC4L):	1, 2, 3 & 4 illuminated buttons	RM-MC51L:	6 x XLR 3-pin male (balanced)	RM-MC4L:	Monitor controller, 4 stereo inputs, 1 stereo output with light control
Output Impedance:	<50Ω	Audio Controls:	DIM & CUT illuminated buttons (not on RM-MCL)	Remote I/O Port:	15 way D-type socket	RM-MC51L:	Monitor controller, 5.1 stereo inputs & outputs with light control
Maximum Output Level:	+25dBu	Volume Control:	Rotary potentiometer for output attenuation on front panel (not on RM-MCL)	Mains Input:	Filtered 3-pin IEC male, continuously rated 85-264VAC, 47-63Hz, fused	RM-MCL:	Monitor light controller, 3 button, TX-STANDBY-REH
Attenuation Range:	>86dB	<b>Rear Panel Connections</b>		Power Consumption:		<b>Physical Specification</b>	
DIM Attenuation Range:	Adjustable -3dB to -23dB via rear panel potentiometer	Audio Inputs (RM-MC1L):	2 x XLR 3-pin female (balanced)	RM-MC1L	Peak 10W, average 4W	Dimensions (Raw):	48cm (W) x 10.8cm (D) x 4.3cm (H) 19" (W) x 4.3" (D) x 1.7" (H) (1U)
Common Mode Rejection:	>66dB typical	Audio Inputs (RM-MC4L):	8 x XLR 3-pin female (balanced)	RM-MC4L	Peak 10W, average 6W	Dimensions (Boxed):	58.5cm (W) x 22.5cm (D) x 7cm (H) 23" (W) x 8.9" (D) x 2.8" (H)
Distortion:	<0.04% ref +8dBu	Audio Inputs (RM-MC51L):	6 x XLR 3-pin female (balanced)	RM-MC51L	Peak 10W, average 7W	Weight :	Nett: 1.3kg    Gross: 1.9kg Nett: 2.9lbs    Gross: 4.2lbs
Crosstalk:	<-80dB @ 1kHz input, ref 0dBu			RM-MCL	Peak 10W, average 2W		
				Fuse Rating:	Anti-surge fuse 1A, 20 x 5mm		

4  
SON AMPLIFIER

**SONIFEX**

*Redbox*





## Redbox Audio & Video Interfaces

The Redbox audio & video interfaces are problem solvers for use in radio, TV & recording studios and video & post production suites. For broadcast applications and where products are being used 24/7, Redbox's outstanding product quality & reliability give you all the assurance you need.

Redbox Introduction	30
Rackmount Kits	31
3G/HD/SD-SDI Video Distribution Amplifiers	32
3G/HD/SD-SDI Video Embedders & De-Embedders	35
Digital Audio Converters	44
Synchronisation Add-On Boards	54
Synchronisers, Delays & Silence Detectors	55
Matching Converters	78
Audio Distribution Amplifiers	87
Phantom Power Supply	108
Headphone Distribution Amplifiers	109
Mixers, Source Selectors & Switchers	114
Microphone Amplifiers & Limiters	127
Stereo to Mono Converters	134
Power Controllers	136
Talkback & Communications	137
Tone Generators	142



*Image of Sonifex Redboxes and Telephone Hybrids in a bus.  
Photo supplied by BTS 98FM, Dublin.*



## Redbox Audio & Video Interfaces

Designed and manufactured to the highest specifications, Redbox is a range of analogue and digital audio & video interfaces for use in a multitude of professional audio applications, including installations at radio stations, TV studios, home studios, video suites, production & post-production houses and recording studios.

Started in 1999, the Redbox range has expanded to include over 75 high quality, versatile and reliable units.

All of the ideas for new products have come from you, the customers, so if you have a requirement for a new interface, or modifications to an existing one, then let us know by sending an email to sales@sonifex.co.uk.

Manufactured to the highest standards in our UK offices, utilisation of the finest components and critical quality control techniques ensure that your Redboxes will work every time for years to come. Designed for 24/7/365 operation for broadcast applications, each Redbox is tested twice by skilled audio engineers, before being carefully assembled and packed.

The Redbox range of products are “fit and forget” because you can set them up, fit them in your installation and then forget about them - they won't trouble you.

### Features

- All are equipped with IEC mains lead and instruction manual.
- In-house design and manufacture ensures high quality control standards.
- All units are 115V 60Hz or 230V 50Hz switchable and all have a front panel LED power indicator.
- Manufactured within ISO9000 standards and guaranteed CE compliant.
- Housed in eye catching red anodised aluminium cases.

All the Redboxes are screw mountable as standard and are either rack-mounted or have the option to be rack-mounted. The RB-RK rack mount kits can be attached to the front or the rear of the Redbox products so that they can be rack mounted into a standard 19 inch rack frame in 1U of space.

### Rack Mounting

For rack mounting smaller (28cm) (11”) units the optional RB-RK1 (Red) or RB-RK1B (Black) kit can be used (which include 4 off M6 panel fixing screws).

### Rear Panel Mounting

For rear panel mounting you can use either the RB-RK2, or RB-RK3, depending on the size of your Redbox.

RB-RK2 1U rear panel rack kit for small Redbox range, e.g., RB-BL2

RB-RK3 1U rear panel rack kit for large Redbox range, e.g., RB-DA6.

The RB-RK1 can be used with the following products:-

<b>RB-SC1</b>	Sample rate converter
<b>RB-UL1</b>	Unbalanced to balanced single converter
<b>RB-UL2</b>	Dual unbalanced to balanced converter
<b>RB-BL2</b>	Unbalanced to balanced bi-directional converter
<b>RB-PA2</b>	Dual stereo RIAA phono amplifier
<b>RB-LI2</b>	Stereo line isolation unit
<b>RB-DDA6A</b>	6 way AES/EBU digital distribution amplifier
<b>RB-DDA6A3</b>	6 way stereo AES3ID digital distribution amplifier
<b>RB-DDA6S</b>	6 way S/PDIF digital distribution amplifier
<b>RB-DDA6W</b>	6 way word clock distribution amplifier
<b>RB-MA1</b>	Single microphone amplifier
<b>RB-MA2</b>	Dual microphone amplifier
<b>RB-ML2</b>	Stereo microphone & line level limiter
<b>RB-SL2</b>	Twin mono, or stereo, limiter

- RB-SM1** Single stereo to mono converter
- RB-SM2** Dual stereo to mono converter
- RB-LC3** Light/Power controller
- RB-MM1** Mix-minus generator

**Front Panel Kits for Redboxes**

A number of customers have asked for non-rackable fronts for the RB-HD1, RB-HD2, RB-ADDA, RB-UL4, RB-BL4 and RB-LU4.

These are available without rack-ears as: RB-FR1, RB-FR2 and RB-FR3.

When Redboxes are shipped to different countries, the correct IEC mains lead is chosen at time of despatch:

UK - 230V, UK 3 pin to IEC lead



EC - 230V, EEC Schuko 2 pin to IEC lead



US - 115V, US 3 pin to IEC lead



AU - 230V, Australasian 3 pin to IEC lead



Wherever you see this symbol an RB-RK1 rackmount kit can be used.



Wherever you see this symbol an RB-RK1B rackmount kit can be used.



Wherever you see this symbol an RB-RK2 small Redbox rear panel rack kit ears can be used.



Wherever you see this symbol an RB-RK3 large Redbox rear panel rack kit ears can be used.



RB-FR1 - Front panel, no 19" mount, for RB-ADDA, RB-UL4, RB-BL4 & RB-LU4.



RB-FR2 - RB-HD1 or RB-DAC1 front panel, no 19" rack mount.



RB-FR3 - RB-HD2 front panel, no 19" rack mount.





## RB-VHDA2x4 3G/HD/SD-SDI 2 Input, 8 Output Video Distribution Amplifier



**Category:** 3G/HD/SD-SDI Video Distribution Amplifiers.

**Product Function:** Distributes 2 x SDI

inputs to 4 outputs, or 1 SDI input to 8 outputs.

**Typical Applications:** Distribution of football HD live feed in OB truck, distribution of video from HD video player.

**Features:** 2 x SDI inputs, 8 outputs, fully reclocked outputs, AC and DC power supplies provide redundancy, web server for setup.

The RB-VHDA2x4 is a high performance, reliable dual input and eight output digital video distribution amplifier for re-clocking and distributing up to two 3G, HD (high definition) or SD (standard definition) SDI sources.

By default, the RB-VHDA2x4 acts as two independent video distribution amplifiers, with input 1 routed to outputs 1-4 and input 2 routed to outputs 5-8. Either input

can also be routed to all outputs if desired which can be selected by the Input Select switch on the front panel or via the built-in webserver. The webserver also provides status information for the unit.

The unit provides automatic input detection, re-clocking and cable equalisation of the input signals to 100/350 meters (HD/SD) of coax cable.



The full range of 3G, SD and HD standards are supported by the unit allowing PAL and NTSC signals up to 1080p 60Hz to be distributed.

Each output is individually buffered providing separately driven outputs for greater reliability.

As well as an AC power input, the unit also has a 12V DC input for use, for example, in outside broadcast vehicles. Both power inputs can be used to give a dual redundant power supply; whichever voltage is higher will be used.

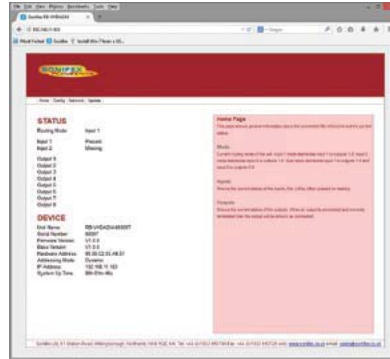

RB-VHDA2x4 Home Page.

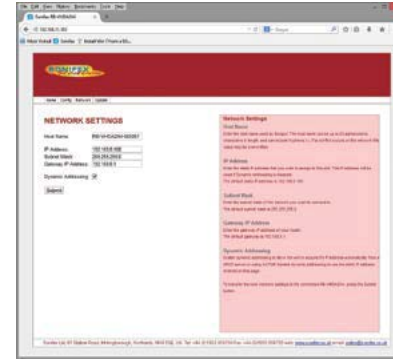

RB-VHDA2x4 Network Page.

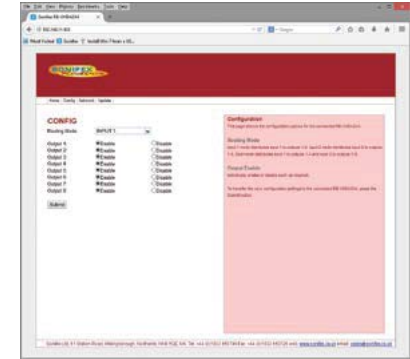

RB-VHDA2x4 Configuration Page.

### Specification For RB-VHDA2X4

#### Audio Specification

Compatible Standards:	SMPTE-424M (3G) SMPTE-292M (HD-SDI) SMPTE-259M-AC1 (SD-SDI) SMPTE 344M DVB-ASI at 270Mb/s
-----------------------	---

<sup>1</sup> Other rates will be passed without relocking.

Impedance:	75Ω terminating
Equalisation:	Up to 100m of Belden 1694A at 1.485Gbps Up to 350m of Belden 1694A at 270 Mbps

Data Rates:	143, 270, 1483.5,
Fully supported	1485, 2967 & 2970Mbps
Passed but not relocked:	177, 360 & 540Mbps

Relocking & Equalisation:	Automatic
Resolution:	Automatic
Return Loss:	>15dB at 1500MHz
Output Jitter:	<0.2UI
Signal Level:	800mV ±10%

#### Front Panel Indicators

Power LED:	Red indicates power is present
Input Status 1 & 2 LEDs:	Green indicates signal is present, flashing red indicates signal is missing.

#### Rear Panel Connections

3G/HD/SD-SDI Video Input:	2 x BNC (Unbalanced)
3G/HD/SD-SDI Video Outputs:	8 x BNC (Unbalanced)
Ethernet Port:	RJ45 with status LEDs
Power Supply: AC:	Filtered IEC, continuously rated 85-264VAC, 47-63Hz, fused, max 10W
Fuse Rating: DC:	Anti-surge fuse 1A 20 x 5mm 12V 300mA max, DC supply, 2.5mm socket fused

#### Equipment Type

RB-VHDA2x4:	3G/HD/SD-SDI 2 inputs, 8 output video distribution amplifier
-------------	--

#### Physical Specification

Dimensions (Raw):	48cm (W) x 10.8cm (D) x 4.3cm (H) 19" (W) x 4.3" (D) x 1.7" (H) (1U)
Dimensions (Boxed):	58.5cm (W) x 22.5cm (D) x 7cm (H) 23" (W) x 8.9" (D) x 2.8" (H)
Weight:	Nett: 1.3kg Gross: 1.9kg Nett: 2.9lbs Gross: 4.2lbs

#### Accessories

RB-RK3:	1U Rear panel rack kit for large Redboxes
---------	---

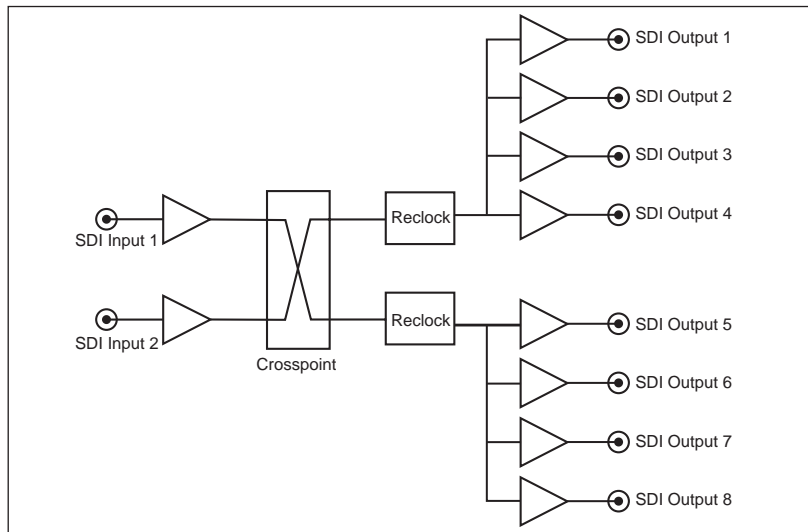

RB-VHDA2x4 Block Diagram.



## RB-VHDA8 3G/HD/SD-SDI 1 Input, 8 Output Video Distribution Amplifier

The RB-VHDA8 is a high performance, reliable eight way digital video distribution amplifier for re-clocking and distributing a 3G, HD (high definition) or SD (standard definition) SDI source to eight outputs. The unit provides automatic input detection, re-clocking and cable equalisation of the input signal to 100/350 meters (HD/SD) of coax cable.

The full range of 3G, HD and SD standards are supported by the unit allowing PAL and NTSC signals up to 1080p 60Hz to be distributed.

Each output is individually buffered providing separately driven outputs for greater reliability.

As well as an AC power input, the unit also has a 12V DC input for use, for example, in outside broadcast vehicles. Both power inputs can be used to give a dual redundant power supply; whichever voltage is higher will be used.

### Specification For RB-VHDA8

#### Audio Specification

Compatible Standards:	SMPTE-424M (3G) SMPTE-292M (HD-SDI) SMPTE-259M-AC <sup>1</sup> (SD-SDI) SMPTE 344M <sup>1</sup> DVB-ASI <sup>2</sup> at 270Mb/s
-----------------------	---

<sup>1</sup> Other rates will be passed without reclocking.

<sup>2</sup> Non inverted outputs only.

Impedance:	75Ω terminating
Equalisation:	Up to 100m of Belden 1694A at 1.485Gbps Up to 350m of Belden 1694A at 270 Mbps
Data Rates:	Fully supported: 143, 270, 1483.5, 1485, 2967 & 2970Mbps Passed but not reclocked: 177, 360 & 540Mbps
Reclocking & Equalisation:	Automatic
Resolution:	Automatic
Return Loss:	>15dB at 1500MHz
Output Jitter:	<0.2UI
Signal Level:	800mV ±10%
<b>Front Panel Indicators</b>	
Power LED:	Amber indicates power is present, Red indicates detection of valid incoming SDI signal

#### Rear Panel Connections

HD/SD-SDI Video Input:	1 x BNC (Unbalanced)
HD/SD-SDI Video Outputs:	8 x BNC (Unbalanced)
Power Supply: AC:	Filtered IEC, continuously rated 85-264VAC, 47-63Hz, fused, max 10W
Fuse Rating:	Anti-surge fuse 2A 20 x 5mm
DC:	12V 300mA max, DC supply, 2.5mm socket fused

#### Equipment Type

RB-VHDA8:	3G/HD/SD-SDI 1 input, 8 output video distribution amplifier
-----------	---

#### Physical Specification

Dimensions (Raw):	48cm (W) x 10.8cm (D) x 4.3cm (H) 19" (W) x 4.3" (D) x 1.7" (H) (1U)
Dimensions (Boxed):	58.5cm (W) x 22.5cm (D) x 7cm (H) 23" (W) x 8.9" (D) x 2.8" (H)
Weight :	Nett: 1.3kg Gross: 1.9kg Nett: 2.9lbs Gross: 4.2lbs

#### Accessories

RB-RK3:	1U Rear panel rack kit for large Redboxes
---------	---





## 3G, HD & SD-SDI Embedders & De-Embedders

Still in the familiar Redbox chassis offering rackmounting as standard and a universal AC power supply, these new video Redboxes use latest technology components to offer embedding and de-embedding for analogue and digital audio signals into and out of single link 3G, HD and SD-SDI video signals, respectively.

With simple front panel controls, standard BNC connectivity and remote operation on serial and ethernet ports, there are currently 6 products in the range:

- **RB-VHDMA8** De-Embedder, 8 Channel Analogue Outputs
- **RB-VHEMA8** Embedder, 8 Channel Analogue Inputs
- **RB-VHCMA4** Embedder & De-Embedder, 4 Channel Analogue I/O
- **RB-VHCMD16** Embedder & De-Embedder, 16 Channel Digital I/O

### Features of the 3G, HD & SD-SDI Embedders & De-Embedders

- Support all standards of single link 3G, HD and SD-SDI.
- Front panel control and remote Ethernet control.
- Two SDI outputs which can be configured independently.
- Input/output audio gain control, depending on unit.
- Analogue and digital audio I/O versions.
- AC power supply.
- 1U rackmount.

### Common Specifications

SDI Specification	
SDI Input:	1 x BNC, 3G/HD/SD-SDI
SDI Outputs:	2 x BNC, 3G/HD/SD-SDI, Re-clocked
Impedance:	75Ω
Output Alignment Jitter:	<0.2UI (3G <0.3UI)
Output Level:	800mV +/- 10%
Return Loss:	<15dB at 1500MHz
SDI Supported Standards:	270Mbps, SMPTE-259M-C (SD) 1.485 or 1.4835Gbps, SMPTE-292M (HD) 2.97 or 2.967Gbps, SMPTE-424M (3G)
Supported Video Formats:	525/59.94 (SMPTE-125M) 625/50 (ITU-R BT.656) 720p/23.98, 24, 25, 29.97, 30, 50, 59.94, 60 (SMPTE-296M) 1035i/59.94, 60 (SMPTE-260M) 1080i/50, 59.94, 60 (SMPTE-274M) 1080p/23.98, 24, 25, 50, 59.94, 60 (SMPTE-274M) 1080pSF/23.98, 24, 25, 29.97, 30 (RP-211) 1080i/50 (SMPTE-295M) 1080p/50 (SMPTE-295M)
Video Delay:	SD: 290 pixels / 22 us HD: 570 pixels / 8 us 3G: 570 pixels / 4 us
Embedded Audio:	48kHz, synchronous SMPTE-272M-ABC SMPTE-299M
Serial Port:	RS232, 9 way D-type
Ethernet Port:	10/100Mbps
Fuse Rating:	Anti-surge fuse 2A 20 x 5mm
Physical Specifications	
Dimensions (Raw):	48cm (W) x 15.8cm (D*) x 4.2cm (H) (1U) 19" (W) x 6.2" (D*) x 1.7" (H) (1U)
Dimensions (Boxed):	59cm (W) x 27.5cm (D*) x 11cm (H) 23.2" (W) x 10.8" (D*) x 4.3" (H)
Weight:	Nett: 1.8kg Gross: 2.3kg Nett: 4.0lb Gross: 5.1lb
Accessories	
RB-RK3:	1U Rear panel rack kit for large Redboxes

\* Note that this product is deeper than standard Redboxes



## RB-VHDMA8 3G/HD/SD-SDI De-Embedder, 8 Channel Analogue Output



**Typical Applications:** De-embed audio from live HD football feed to provide multi-language radio commentaries, de-embed audio to pass to analogue speaker system.

**Features:** Balanced & unbalanced analogue outputs, independent output level controls, 2 x independent SDI outputs, Ethernet or front panel control & configuration.

**Category:** 3G/HD/SD-SDI Video Embedders & De-Embedders.

**Product Function:** De-embeds from SDI stream to 8 analogue outputs.

The RB-VHDMA8 is an 8 channel analogue de-embedder contained in a single 19-inch rack unit. The unit can selectively de-embed up to 8 channels within any audio group of an SDI video signal, to any of the analogue outputs. After which, the video becomes two independent paths, where the audio groups can be selectively deleted or passed through and then sent to the re-clocked SDI outputs.

The de-embedding channel routing is controlled via the front panel buttons and indicators. There is also LED indication for SDI input status and audio group presence.

The unit can be remote controlled via Ethernet or serial port connections using the Sonifex Sci software.

It has a triple rate SDI receiver with automatic input rate detection and equalisation along with two re-clocked and individually buffered SDI outputs. It supports the full range of



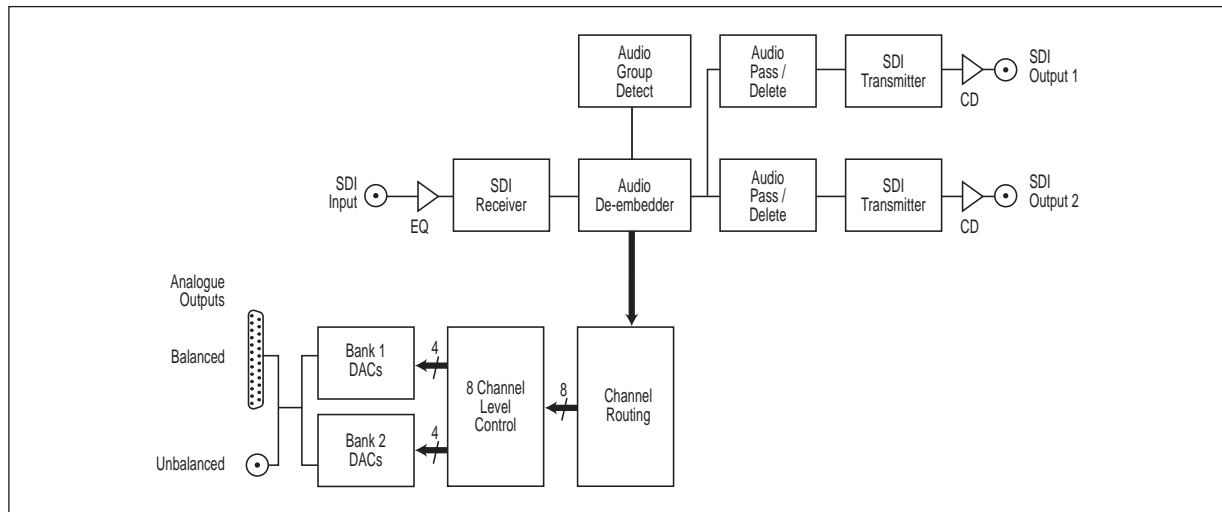

RB-VHDM8 System Block Diagram.

single link 3G, HD and SD standards from NTSC and PAL up to 1080p 60Hz. There is independent level control for each analogue output channel, which can be adjusted from -24dB through to +24dB in 0.5dB steps.

The analogue outputs have three full-scale gain settings which can be set via jumpers inside the unit. Allowable settings are +12dBu, +18dBu and +24dBu reference FSD.

The balanced and unbalanced output connections are paralleled, allowing one type to be used per output.

### Specification for RB-VHDM8

#### Audio Specification

##### Front Panel Controls & Indicators

De-embed Bank Select:	Bank 1 or 2
Bank Channel Select:	Channels 1,2,3 or 4
Group Select:	Groups 1,2,3 or 4
Group Channel Select:	Group channels 1,2,3 or 4
Status:	1 x SDI input status LED 2 x SDI output LEDs 4 x Audio group status LEDs

##### Audio Specifications

Max Output Level:	+24dBu (balanced)
Output Impedance:	<50Ω (balanced)
Gain Range:	12dBu, 18dBu or 24dBu ref FSD (jumper selectable)

Signal to Noise: Better than -106dB (RMS A-weighted at 24-bit, balanced)

Distortion and Noise: Better than -85dB THD+N at 1kHz (balanced)

De-embed Delay: 3G/HD/SD: 1.1 ms

#### Connections

Analogue Audio Outputs: 8 output channels via BNC (unbalanced) or D-type socket (balanced)

Analogue Audio: 8 x BNC

Connectors: 2 x 25-way D-type

Power Supply: Universal filtered IEC, continuously rated 85-264VAC @47-63Hz, fused, max 14W

#### Equipment Type

RB-VHDM8 3G/HD/SD-SDI De-embedder, 8 channel analogue outputs



Sci Audio Output Levels Page.

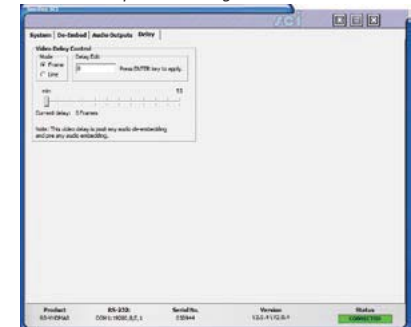

Sci Delay Page.

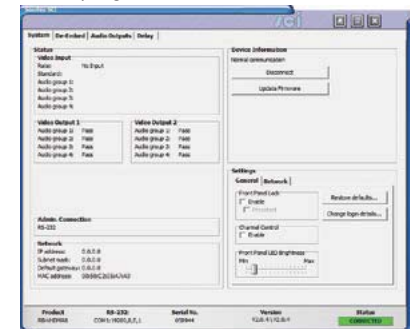

Sci System Page.



## RB-VHEMA8 3G/HD/SD-SDI Embedder, 8 Channel Analogue Inputs



**Typical Applications:** Embed different language commentaries to live HD football feed, embed remixed 5.1 + stereo music onto HD concert footage.

**Features:** Balanced & unbalanced analogue inputs, independent input level controls, 2 x independent SDI outputs, Ethernet or front panel control & configuration.

**Category:** 3G/HD/SD-SDI Video Embedders & De-Embedders.

**Product Function:** Embeds 8 analogue inputs to 2 x SDI streams.

The RB-VHEMA8 is an 8 channel analogue embedder contained in a single 19-inch rack unit. The unit can selectively embed up to 8 analogue channels onto either of the two output video paths which are sent to the re-clocked SDI outputs. It also has the capability to allow audio groups to be deleted or passed through on each of the two video paths prior to the embedding process.

The embedding channel routing is controlled via the front panel buttons and indicators. There is also LED indication for SDI input status and audio group presence.

The unit can be remote controlled via Ethernet or serial port connections using the Sonifex SCI software.

It has a triple rate SDI receiver with automatic input rate detection and equalisation along with two re-clocked and individually buffered SDI outputs. It supports the full range of single link 3G, SD



and HD standards from NTSC and PAL up to 1080p 60Hz.

There is independent level control for each analogue input channel, which can be adjusted from -24dB through to +24dB in 0.5dB steps. The analogue inputs have three full-scale gain settings which can be set via jumpers situated inside the unit. Allowable settings are +12dBu, +18dBu and +24dBu for FSD.

The balanced and unbalanced input connections are paralleled, allowing one type to be used per input.

**Specification For RB-VHEMA8**

<b>Audio Specification</b>	
<b>Front Panel Controls &amp; Indicators</b>	
Embed Bank Select:	Bank 1 or 2
Bank Channel Select:	Channels 1, 2, 3 or 4
Group Select:	Groups 1, 2, 3 or 4
Group Channel Select:	Group channels 1,2,3 or 4
Status:	1 x SDI input status LED 2 x SDI output LEDs 4 x Audio group status LEDs
<b>Audio Specifications</b>	
Maximum Input Level:	+27dBu (balanced)
Input Impedance:	>10kΩ bridging (balanced)
Input Levels:	+12dBu, +18dBu or +24dBu for FSD (jumper selectable)
Signal to Noise:	Better than -113dBFS (RMS A-weighted at 24-bit, balanced)

Distortion and Noise: Better than -100dB THD+N at 1kHz (balanced)

Embed Delay: SD: 600 us  
3G/HD: 300 us

**Connections**

Analogue Audio Inputs: 8 input channels via BNC (unbalanced) or D-type socket (balanced)

Analogue Audio Connectors: 8 x BNC  
2 x 25-way D-type

Power Supply: Universal filtered IEC, continuously rated 85-264VAC @47-63Hz, fused, max 18W

**Equipment Type**

RB-VHEMA8 3G/HD/SD-SDI embedder, 8 channel analogue inputs

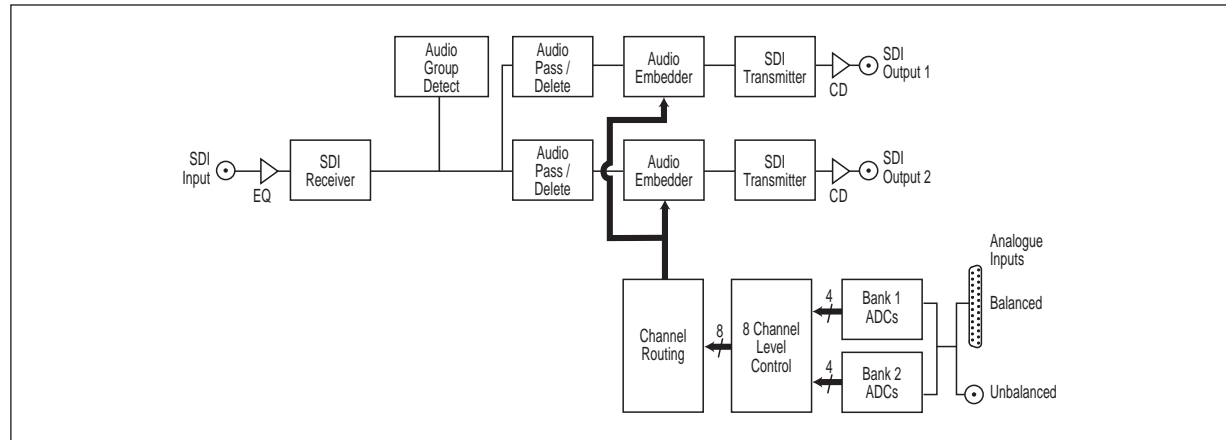

RB-VHEMA8 System Block Diagram.

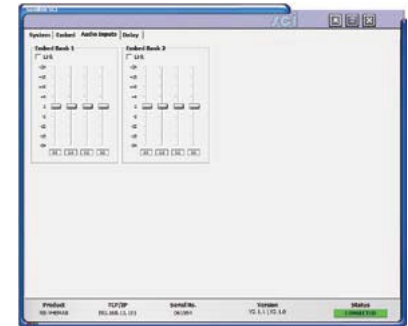

Sci Audio Inputs Page.

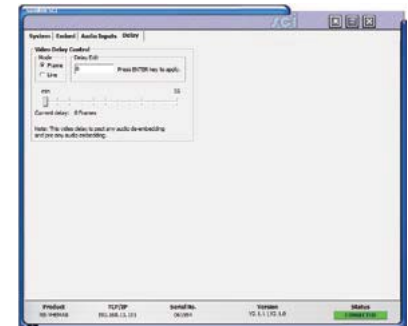

Sci Delay Page.

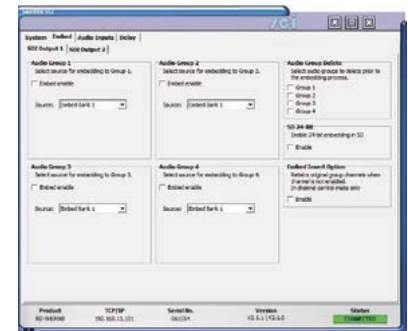

Sci Embed Page.



## RB-VHCMA4 3G/HD/SD-SDI Embedder & De-Embedder 4 Channel Analogue I/O



**Category:** 3G/HD/SD-SDI Video Embedders & De-Embedders.

**Product Function:** De-embeds from 1 SDI stream to 4 analogue outputs & embeds 4 analogue inputs to 2 x SDI streams.

**Typical Applications:** To add post production audio processes, commentary & sound effects to an HD video feed (De-embed, add effects, re-embed).

**Features:** Balanced & unbalanced analogue inputs & outputs, independent input & output level controls, 2 x independent SDI outputs, Ethernet or front panel control & configuration.

The RB-VHCMA4 is a 4-channel analogue de-embedder and a 4-channel analogue embedder combined into a single 19-inch rack unit. The unit can selectively de-embed up to 4 channels within any audio group of an SDI video signal, to any of the analogue outputs. After which, the video becomes two independent paths where the audio groups can be selectively deleted or passed through. The unit then embeds any of the 4 analogue input channels to available groups within each of the two video paths, which are then sent to the re-locked SDI outputs.

The de-embedding and embedding channel routing is controlled via the front panel buttons and indicators. There is also LED indication for SDI input status and audio group presence.

The unit can be remote controlled via Ethernet or serial port connections using the Sonifex Sci software.

It has a triple rate SDI receiver with automatic input rate detection and equalisation along with two re-locked and individually buffered SDI outputs. It supports the full range of single link 3G, SD and HD standards from NTSC and PAL up to 1080p 60Hz.

There is independent level control for each analogue input and output channel, which can be adjusted from -24dB through to +24dB in 0.5dB steps. The analogue outputs have three full-scale gain settings which can be set via jumpers situated inside the unit. Allowable settings are +12dBu, +18dBu and +24dBu reference FSD. Similarly, the analogue inputs full-scale gain settings can be set via jumpers inside the unit. Allowable settings are +12dBu, +18dBu and +24dBu for FSD.

The balanced and unbalanced connections are paralleled, allowing one type to be used per input or output.

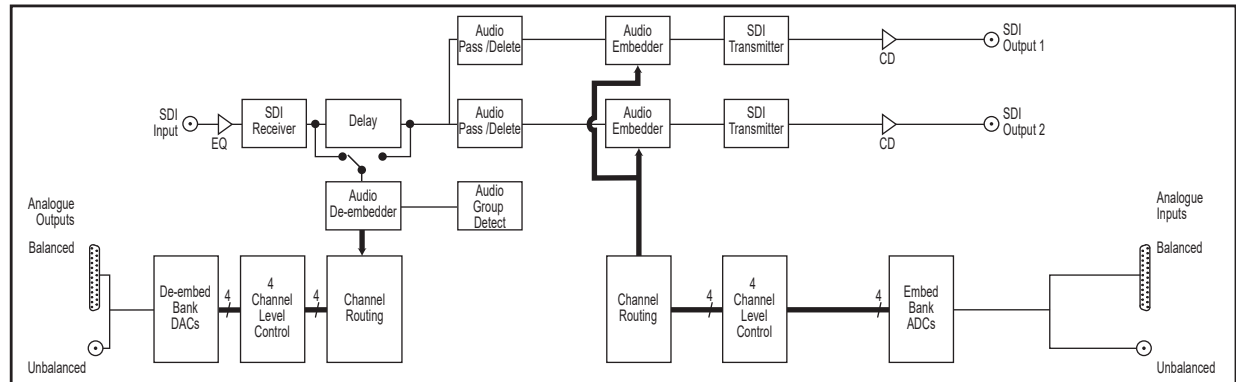

RB-VHCMA4 System Block Diagram.





### Specification For RB-VHCMA4

#### Front Panel Controls & Indicators

Bank Select:	De-embed bank or embed bank
Bank Channel Select:	Channels 1,2,3 or 4
Group Select:	Groups 1,2,3 or 4
Group Channel Select:	Group channels 1,2,3 or 4
Status:	1 x SDI input status LED 2 x SDI output LEDs 4 x Audio group status LEDs

#### Audio Specifications

<b>Analogue Inputs</b>	
Maximum Input Level:	+27dBu (balanced)
Input Impedance:	>10kΩ bridging (balanced)
Input Levels:	+12dBu, +18dBu or +24dBu for FSD (jumper selectable)
Signal to Noise:	Better than -113dBFS (RMS A-weighted at 24-bit, balanced)
Distortion and Impedance:	Better than -100dB THD+N at 1kHz (balanced)

#### Analogue Outputs

Max Output Level:	+24dBu (balanced)
-------------------	-------------------

Output Impedance:	<50Ω (balanced)
Gain Range:	12dBu, 18dBu or 24dBu ref FSD (jumper selectable)
Signal to Noise:	Better than -106dB (RMS A-weighted at 24-bit, balanced)
Distortion and Noise:	Better than -85dB THD+N at 1kHz (balanced)
De-embed Delay:	3G/HD/SD: 1.1 ms
Embed Delay:	SD: 600 us 3G/HD: 300 us

#### Connections

Analogue Audio Inputs:	4 input channels via BNC (unbalanced) or D-type (balanced)
Analogue Audio Outputs:	4 output channels via BNC (unbalanced) or D-type (balanced)
Analogue Audio Connectors:	8 x BNC 2 x 25-way D-type socket
Power Supply:	Universal filtered IEC, continuously rated 85-264VAC @47-63Hz, fused, max 16W

#### Equipment Type

RB-VHCMA4	3G/HD/SD-SDI embedder & de-embedder, 4 channel analogue I/O
-----------	---

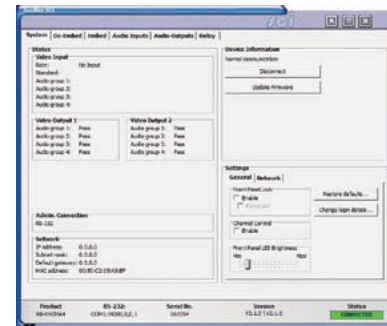

SCi System Page.

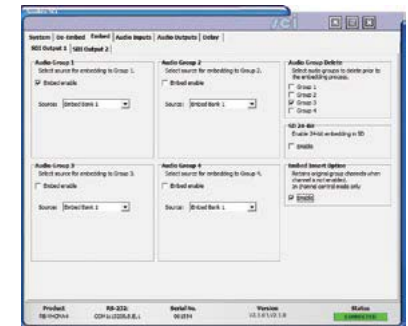

SCi Embed Page.



## RB-VHCMD16 3G/HD/SD-SDI Embedder & De-Embedder 16 Channel Digital I/O



**Typical Applications:** To add post production audio processes, commentary & sound effects to an HD video feed (De-embed, add effects, re-embed).

**Category:** 3G/HD/SD-SDI Video Embedders & De-Embedders.

**Product Function:** De-embeds from 1 SDI stream to 16 digital outputs & embeds 16 digital inputs to 2 x SDI streams.

**Features:** Selectable unbalanced or balanced digital inputs & outputs, independent input & output level controls, 2 x independent SDI outputs, Ethernet or front panel control & configuration.

The RB-VHCMD16 is a 16-channel de-embedder and 16 channel embedder combined into a single 19-inch rack unit. The unit can selectively de-embed any channel within any audio group of an SDI video signal, to any of the digital outputs. After which, the video becomes two independent paths where the audio groups can be selectively deleted or passed through. The unit then embeds any of the digital input channels to available groups within each of the two video paths, which are then sent to the re-clocked SDI outputs.

The de-embedding and embedding channel routing is controlled via the front panel buttons and indicators. There is also LED indication for SDI input status and audio group presence.

The unit can be remote controlled via Ethernet or serial port connections using the Sonifex SCI software.

It has a triple rate SDI receiver with automatic input rate detection and equalisation along with two re-clocked and individually buffered SDI outputs. It supports the full range of single link 3G, HD and SD standards from NTSC and PAL up to 1080p 60Hz.



Each digital input is normally sample rate converted to 48kHz before embedding, so that it is synchronous to the video input, though sample rate conversion can be bypassed on a per input basis allowing SMPTE-337M data to be embedded. All

digital outputs are output at 48kHz, synchronous to the video input. There is independent level control for each digital input and output channel, which can be adjusted from -24dB to +24dB in 0.5dB steps.

The digital audio I/O connections are transformer-coupled balanced line interfaces and can be configured to be either 75ohm (AES 3ID) or 110ohm (AES 3) impedance through either a BNC or D-type connector. These connections are paralleled, allowing one type to be used per input or output.

**Specification For RB-VHCMD16**

**Front Panel Controls & Indicators**

Bank Select:	Bank 1, 2, 3 or 4
Bank Channel Select:	Channels 1,2,3 or 4
Function Select:	De-embed or embed
Group Select:	Groups 1,2,3 or 4
Group Channel Select:	Group channels 1,2,3 or 4
Status:	1 x SDI input status LED 2 x SDI output LEDs 4 x Audio group status LEDs

**Audio Specifications**

Output Sample Rate:	48kHz
Input Sample Rates:	32-192kHz, sample rate converted to 48kHz
Input & Output Impedance:	110Ω or 75Ω (jumper selectable)
Signal Level (un-terminated):	Balanced: 3Vp-p +/- 20% Unbalanced: 2Vp-p +/- 20%
Dynamic Range:	138dB
Distortion and Noise:	< -137dB THD+N at 997Hz, ref 0dBFS
De-embed Delay:	3G/HD/SD: 330 us
SRC Input Delay:	192 kHz: 1.3 ms 96 kHz: 1.83 ms 48 kHz: 2.9 ms
Embed Delay:	SD: 600 us + SRC Input Delay 3G/HD: 300 us + SRC Input Delay

**Connections**

Digital Audio Outputs:	16 outputs via 8 BNCs (AES 3ID) or D-type (AES/EBU)
Digital Audio Inputs:	16 inputs via 8 BNCs (AES 3ID) or D-type (AES/EBU)
Digital Audio Connectors:	16 x BNC 2 x 25-way D-type socket
Power Supply:	Universal filtered IEC, continuously rated 85-264VAC @47-63Hz, fused, max 13W

**Equipment Type**

RB-VHCMD16	3G/HD/SD-SDI embedder & de-embedder 16 channel digital I/O
------------	--

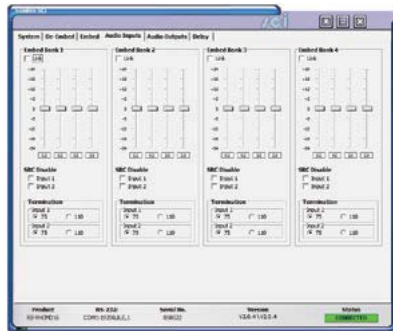

SCI Audio Inputs Page.

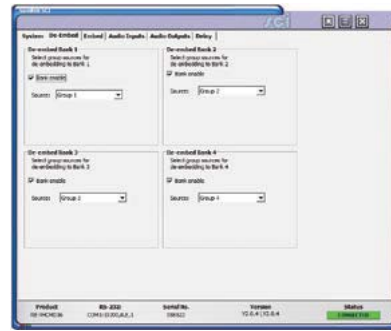

SCI De-Embed Page.

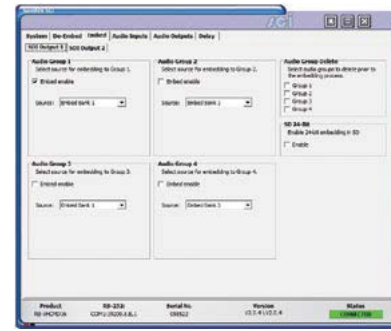

SCI Embed & SDI Output Page.

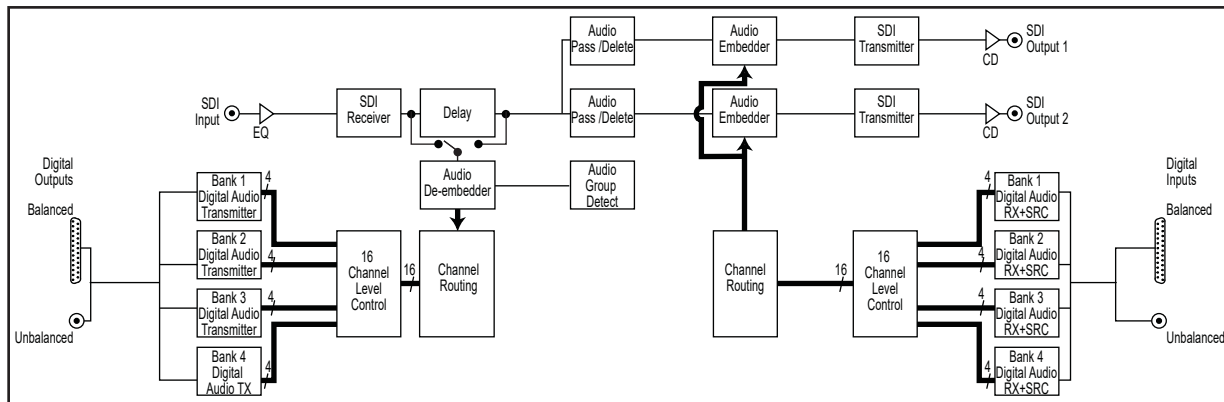

RB-VHCMD16 System Block Diagram.



## RB-ADDA Combined A/D and D/A Converter



**Category:** Digital Audio Converters.

**Product Function:** Converting stereo analogue audio to digital & vice-versa.

**Typical Applications:**

- Interfacing professional or domestic audio devices e.g. ipods, cassette recorders or telephone balance units into digital environments.

**Features:**

- Balanced & unbalanced inputs.
- Balanced & unbalanced outputs.
- AES/EBU & S/PDIF I/O.
- Sample rates up to 24 bit 96kHz.

The RB-ADDA A/D and D/A converter is a 1U rack-mount which produces an AES/EBU or S/PDIF level digital audio output from a balanced XLR or unbalanced phono stereo audio input. It also produces a stereo balanced XLR or unbalanced phono output from an incoming AES/EBU or S/PDIF digital input signal.

The unit operates in four modes:

**Master Mode** - In this mode the unit receives an analogue audio signal, which is digitised and formatted for digital serial transmission (IEC958). The necessary clock signals are generated internally from an on board master clock at a selectable rate (32kHz, 44.1kHz, 48kHz or 96kHz).

**Slave Mode** - In this mode the unit automatically detects the presence of a digital audio sync signal, if present at the digital input, and synchronises the digital output to it. If no sync is present, no output will be generated.

**Auto Mode** - Here the unit synchronises to the digital audio sync signal if present at the digital input and uses the internal master clock only if no sync input signal is detected. In this case, the internal master clock is used at the selected sample rate.

**Auto Lock Mode** - This operates like the auto mode except that if no sync input signal is detected, it will use the internal master clock to sync to the sample rate which was last clocked to.

When operating in sync modes, the front panel power LED flashes whenever the unit is not synchronised to the incoming digital signal.

The analogue inputs have left and right level controls using pre-set potentiometers and DIP switches allowing a signal range from +9dBu to +27dBu. The RCA phono inputs have a further 10dB gain incorporated to give a total gain range of -1dBu to +17dBu for full-scale digits.

The analogue outputs have an output level control, allowing full-scale settings selectable from +12dBu, +18dBu or +24dBu. There are factory-set internal level controls for the analogue outputs allowing gain adjustment of  $\pm 1$ dB.

There are buttons to select either the AES/EBU or S/PDIF input or output for the D/A and A/D sections respectively.

The output bit depth can be selected from 16, 20 or 24 bits. Inputs of a different bit depth to the output are dithered using a noise filter.

For the digital output, there is a switch available to define the content of the channel status bits embedded within the digital audio stream. The status bits can be forced to either Professional or Consumer Mode.



Additionally, if de-emphasis is selected, the RB-ADDA will decode 50/15µs emphasis when indicated by certain channel status bits in the incoming digital audio data.

The RB-ADDA has a calibration routine for optimum performance, which allows the noise floor and dynamic range to improve by 1-2dB.

The calibration cycle operates by calibrating the gain and the zero reference of the A/D converter.

### Specification For RB-ADDA

<b>Audio Specification</b>	
<b>Digital to Analogue Conversion</b>	
<b>D/A Audio Specification For RB-ADDA</b>	
Maximum Output Level:	+24dBu balanced output, +14dBu unbalanced output
Output Impedance:	<50Ω balanced, <75Ω unbalanced
Dynamic Range:	>100dB
Gain Range:	Selectable 12dBu, 18dBu or 24dBu output level, ref FSD
<b>D/A Connections</b>	
Digital Inputs:	1 x AES/EBU XLR 3 pin female 1 x S/PDIF RCA phono
Analogue Outputs:	2 x XLR 3 pin male (balanced) 2 x RCA phono (unbalanced)
<b>Analogue to Digital Conversion</b>	
<b>A/D Audio Specification For RB-ADDA</b>	
Maximum Input Level:	+27dBu balanced inputs, +17dBu unbalanced inputs
Input Impedance:	>10kΩ unbalanced, >20kΩ bridging balanced
Dynamic Range:	>110dB

Gain Range:	Adjustable input gain of ±3dB on 12dBu, 18dBu or 24dBu, ref FSD
Distortion and Noise:	>96dB THD + N at 1kHz
<b>A/D Connections</b>	
Analogue Inputs:	2 x XLR 3 pin (balanced) 2 x RCA phono (unbalanced)
Digital Outputs:	1 x AES/EBU XLR 3 pin male 1 x S/PDIF RCA phono
Mains Input:	Filtered IEC, switchable 110-120V, or 220-240V, fused, 10W max
Fuse Rating:	Anti-surge fuse 100mA 20 x 5mm (230VAC) Anti-surge fuse 250mA 20 x 5mm (115VAC)
<b>Operational Controls</b>	
Analogue Input Select:	XLR or phono, via push-switch
Digital Output Select:	AES/EBU or S/PDIF, via push-switch
Digital Input Select:	AES/EBU or S/PDIF, via push-switch
De-emphasis On/Off:	DIP switch

Input Level Adjust:	DIP switch & pre-set pots
Sample Rates:	Master rates of 32kHz, 44.1kHz, 48kHz or 96kHz, or can synchronise to incoming 32kHz to 100kHz sample rate
Bit Depth:	16, 20 or 24 bits via DIP switch
Modes & Frequencies:	16 way rotary DIP switch
Channel Status Bits:	Forced to consumer mode or professional mode, via DIP switch
Output Level Adjust:	DIP switch
<b>Equipment Type</b>	
RB-ADDA:	Combined A/D and D/A converter
<b>Physical Specification</b>	
Dimensions (Raw):	48cm (W) x 10.8cm (D) x 4.2cm (H) (1U) 19" (W) x 4.3" (D) x 1.7" (H) (1U)
(Boxed):	58.5cm (W) x 22.5cm (D) x 7cm (H) 23" (W) x 8.9" (D) x 2.8" (H)
Weight:	Nett: 1.6kg Gross: 2.2kg Nett: 3.5lbs Gross: 4.8lbs





## RB-ADDA2 A/D and D/A Converter, 24 bit 192kHz



**Category:** Digital Audio Converters.

**Description:** Combined A/D and D/A Converter (24 bit, 192kHz Capable) (1U).

**Product Function:** Converting stereo analogue audio to digital & vice-versa.

**Typical Applications:**

- Interfacing professional or domestic

audio devices i.e. ipods or telephone balance units into digital environments.

- Recording studios/post production where easy access to settings is required.

**Features:**

- Front panel switches.
- Coax/optical digital I/O.
- Separate sync for A to D and D to A allows independent use.
- RS232 for remote setting/control via Sonifex SCI software.

The RB-ADDA2 A/D and D/A converter is a 1U rack-mount which produces an AES/EBU, S/PDIF or TOSlink optical level digital audio output from a balanced XLR or unbalanced phono stereo audio input. It also produces a stereo balanced XLR or unbalanced phono output from an incoming AES/EBU, S/PDIF or TOSlink optical digital input signal.

The RB-ADDA2 is a high performance, enhanced version of the RB-ADDA providing the following additional features:

- It supports higher sample frequency rates up to and including 176.4kHz and 192kHz.
- It has additional independent AES/EBU and Word Clock synchronising inputs, so that the A/D and D/A sections can operate independently, with the digital outputs synchronised to an external master reference clock.
- It has TOSlink optical digital audio I/O.
- It has front panel push-button switches for all the main settings. The buttons are arranged in sets, where pressing the button advances the current selection and LED indicator.

- An RS232 port allows RB-ADDA2 settings to be controlled remotely. The front panel LED indicators alter automatically when using RS232 commands.

The A/D SOURCE push-button is used to select from either the balanced or unbalanced stereo analogue inputs and this push-button also defines the input level for full scale digits at one of +12dBFS, +18dBFS or +24dBFS. These values can then be fine-tuned by using rear-panel pre-set potentiometers which give another ±3dB of gain adjustment, allowing a signal range from +9dBu to +27dBu. The RCA phono inputs have a further 10dB gain incorporated to give a total gain range of -1dBu to +17dBu for full-scale digits.

For the digital output, there are three push-button switches to select the sample frequency, bit depth and status bit modes. FREQUENCY allows selection of the master sample frequency from one of 32kHz, 44.1kHz, 48kHz, 88.2kHz, 96kHz, 176.4kHz or 192kHz. BITS sets the output bit depth as one of 16, 20 or 24 bits, and CS DATA defines the content of the channel status bits embedded within the digital audio stream. The status bits can be forced to Professional Mode (PRO), Consumer Mode (CON) or to follow the mode of the input (FOLLOW).

The SYNC button is used to select the synchronisation input, from Word Clock, AES/EBU or the D/A input, and also the synchronisation mode of the digital output. The A/D section of the RB-ADDA2 operates in four selectable modes:

**Master Mode** - In this mode the unit receives an analogue audio signal, which is digitised and formatted for digital serial transmission (IEC958). The necessary clock signals are generated internally from an on board master clock at a selectable rate (32kHz, 44.1kHz, 48kHz, 88.2kHz, 96kHz, 176.4kHz or 192kHz).

**Slave Mode** - Here the unit is synchronised to an external source, using the digital audio sync or D/A input signal from which the clock signals are stripped, or to the TTL level Word Clock. The FREQUENCY LED indicates the synchronised sample frequency and if no sync is present, no output is generated.

**Auto Mode** - Here the unit is synchronised to an external source, using the digital audio sync or D/A input signal from which the clock signals are stripped, or to the TTL level Word Clock. If no sync signal is present the unit runs from the onboard master clock at a rate selected by the front panel control (32kHz, 44.1kHz, 48kHz, 88.2kHz, 96kHz, 176.4kHz or 192kHz).

**Auto Lock Mode** - This operates like the auto mode except that if no sync signal is present the unit runs at the closest master clock rate to the last locked incoming signal. The FREQUENCY LED indicates the synchronised sample frequency.

When operating in sync modes, the SYNC button flashes whenever the unit is not synchronised to the incoming digital signal.

The D/A section has a SOURCE push-button which selects the digital input source from

AES/EBU, S/PDIF or Toslink optical and which also sets the analogue output level to be generated for full scale digits, from either +12dBFS, +18dBFS or +24dBFS. There are factory-set internal level controls for fine tuning the analogue output gain adjustment. If no digital audio source is present, the D/A SOURCE button flashes. In both A/D and D/A sections, audio is sent to all of the outputs simultaneously. The RB-ADDA2 automatically decodes 50/15µs emphasis if this is indicated by certain channel status bits in the incoming digital audio data. A red LED indicates when power to the RB-ADDA2 is on.

### Specification For RB-ADDA2

<b>Audio Specification</b>	
<b>Analogue to Digital Conversion</b>	
<b>A/D Audio Specification For RB-ADDA2</b>	
Maximum Input Level:	+27dBu balanced inputs, +17dBu unbalanced inputs
Input Impedance:	>10kΩ unbalanced, >20kΩ bridging balanced
Dynamic Range:	>110dB
Gain Range:	Adjustable input gain of ±3dB on selected +12dBu, +18dBu or +24dBu, ref FSD
Distortion & Noise:	>96dB THD + N at 1kHz
<b>A/D Connections</b>	
Analogue Inputs:	2 x XLR 3 pin (balanced) 2 x RCA phono (unbalanced)
Sync Inputs:	1 x AES/EBU XLR 3 pin female 1 x TTL Word clock BNC
Digital Outputs:	1 x AES/EBU XLR 3 pin male 1 x S/PDIF RCA phono 1 x Toslink optical
Serial RS232:	1 x 9 pin D-type plug
Mains Input:	Filtered IEC, continuously rated 85-264VAC @ 47-63Hz, 10W max
Fuse Rating:	Anti-surge fuse 1A 20 x 5mm
<b>A/D Operational Controls</b>	
Analogue Input Source:	Balanced XLR or unbalanced phono, via A/D SOURCE push-button

Analogue Input Level for FSD:	+12dBFS, +18dBFS or +24dBFS, via A/D SOURCE push-button
Analogue Input Level Adjust:	+9dBu to +27dBu via rear-panel pre-set pots
Sample Frequency Rates:	32kHz, 44.1kHz, 48kHz, 88.2kHz, 96kHz, 176.4kHz or 192kHz, via FREQUENCY push-button
Bit Depth:	16, 20 or 24 bits, via BITS push-button
Channel Status Bits:	Consumer mode, professional mode or follow input, via CS DATA push-button
Sync Input Select:	AES/EBU, Word Clock or D/A input, via SYNC push-button
Sync Mode Select:	Master, slave, auto, auto lock, via SYNC push-button
<b>Digital to Analogue Conversion</b>	
<b>D/A Audio Specification For RB-ADDA2</b>	
Maximum Output Level:	+24dBu balanced output, +14dBu unbalanced output
Output Impedance:	<50Ω balanced, <75Ω unbalanced
Dynamic Range:	>110dB
<b>D/A Connections</b>	
Digital Inputs:	1 x AES/EBU XLR 3 pin female 1 x S/PDIF RCA phono 1 x Toslink optical
Analogue Outputs:	2 x XLR 3 pin male (balanced) 2 x RCA phono (unbalanced)
<b>D/A Operational Controls</b>	
Digital Input Select:	AES/EBU, S/PDIF or Toslink optical, via push-button
Analogue Output Level for FSD:	Selectable +12dBu, +18dBu or +24dBu output level, ref FSD, via D/A SOURCE push-button
<b>Equipment Type</b>	
RB-ADDA2:	Combined A/D and D/A converter, 24 bit 192kHz
<b>Physical Specification</b>	
Dimensions (Raw):	48cm (W) x 15.8cm (D*) x 4.2cm (H) (1U) 19" (W) x 6.2" (D*) x 1.7" (H) (1U)
(Boxed):	59cm (W) x 27.5cm (D*) x 11cm (H) 23.2" (W) x 10.8" (D*) x 4.3" (H)
Weight:	Nett: 1.6kg Gross: 2.3kg Nett: 3.5lbs Gross: 5lbs
* Note that this product is deeper than standard Redboxes.	



## RB-SC1 Sample Rate Converter



**Category:** Digital Audio Converters.

**Description:** Sample Rate Converter (24 bit, 96kHz Capable).

**Product Function:** Transferring digital audio between digital equipment.

**Typical Applications:** Converting an audio library from 44.1kHz to 48kHz, transferring digital audio from a recorder at 48kHz to a digital mixer at 96kHz.

Ideal for the transfer of digital audio between different digital equipment, the RB-SC1 sample rate converter standardises the sample rate of a digital audio signal to one of 32kHz, 44.1kHz, 48kHz or 96kHz, or to a synchronising input.

Both audio inputs and outputs have push-button switches to select either AES/EBU or S/PDIF. The synchronising input can be selected from one of AES/EBU, S/PDIF or TTL word clock.

There are four modes of operation of the RB-SC1 dependent on how you want to synchronise the output to the input :

**Master Mode** - In this mode the digital output sample rate is simply set by, and locked to, the internal on-board clock generator. No sync signal is used or required.

**Auto Sync Mode** - In this mode the digital output sample rate follows the sync input. When the sync signal is not present the output sample rate will be set by, and locked to, the internal on-board clock generator at a frequency determined by the switch position.

**Auto Lock Mode** - In this mode no output will be generated until lock is achieved with a sync signal. The digital output sample rate now follows the sync input. If the sync signal is removed then the output sample rate will be

set by, and locked to, the internal on-board clock generator at the closest frequency available to the previous sync input.

**Slave Mode** - In this mode the digital output sample rate follows the sync input. When the sync signal is not present the digital output is turned off.

There are also switches available to define the content of the channel status bits embedded within the digital audio stream. The channel status bits will be forced to Professional Mode for sample rates above 48kHz as they are not supported by the Consumer Mode. For sample rates of 32kHz, 44.1kHz and 48kHz, the status bits can be

either set to follow the input signal type, or can be forced to either Professional or Consumer Mode.

As well as indicating that power is present on the unit, the LED on the front panel has a secondary role to indicate the status of the digital inputs. Fast flashing between red and amber indicates a loss of a digital input signal and slow flashing between red and amber indicates the absence of a synchronising input when not in Master Mode.

**Specification For RB-SC1**

**Audio Specification**

Dynamic Range:	120dB
Distortion and Noise:	-114dB THD + N at 1kHz, ref 0dB FS
Input Impedance:	75Ω S/PDIF inputs 110Ω AES/EBU input 50Ω BNC TTL word clock input
Sample Frequency Range:	Master rates of 32kHz, 44.1kHz, 48kHz or 96kHz, or can synchronise to incoming 32kHz to 100kHz sample rate
Bit Depth:	Up to and including 24 bit

**Rear Panel Connections and Controls**

Inputs:	2 x AES/EBU XLR 3 pin female (audio and sync) 2 x S/PDIF RCA phono (audio and sync) 1 x TTL BNC female (sync)
Outputs:	1 x AES/EBU XLR 3 pin male 1 x S/PDIF RCA phono
Input Select:	Push-button switch between AES/EBU and S/PDIF

Output Select:	Push-button switch between AES/EBU and S/PDIF
Sync Select:	Push-button switch between AES/EBU and S/PDIF, with DIP switch selection between TTL and the other two inputs.
Operational Modes:	Master mode, auto sync mode, auto lock mode and slave mode, set via rotary switch
Status Bits:	Forced to consumer mode, professional mode, or set to follow input with DIP switch selection.
Mains Input:	Filtered IEC, continuously rated 85-264VAC @ 47-63Hz, max 10W
Fuse Rating:	Anti-surge fuse 100mA 20 x 5mm (230VAC) Anti-surge fuse 250mA 20 x 5mm (115VAC)

**Equipment Type**

RB-SC1:	Sample rate converter
---------	-----------------------

**Physical Specification**

Dimensions (Raw):	28cm (W) x 10.8cm (D) x 4.2cm (H) (1U) 11" (W) x 4.3" (D) x 1.7" (H) (1U)
Dimensions (Boxed):	36cm (W) x 20.5cm (D) x 6cm (H) 14.2" (W) x 8" (D) x 2.4" (H)
Weight:	Nett: 1.0kg Gross: 1.4kg Nett: 2.2lbs Gross: 3.1lbs

RB-SC1 Sample Rate Converter Flowchart.

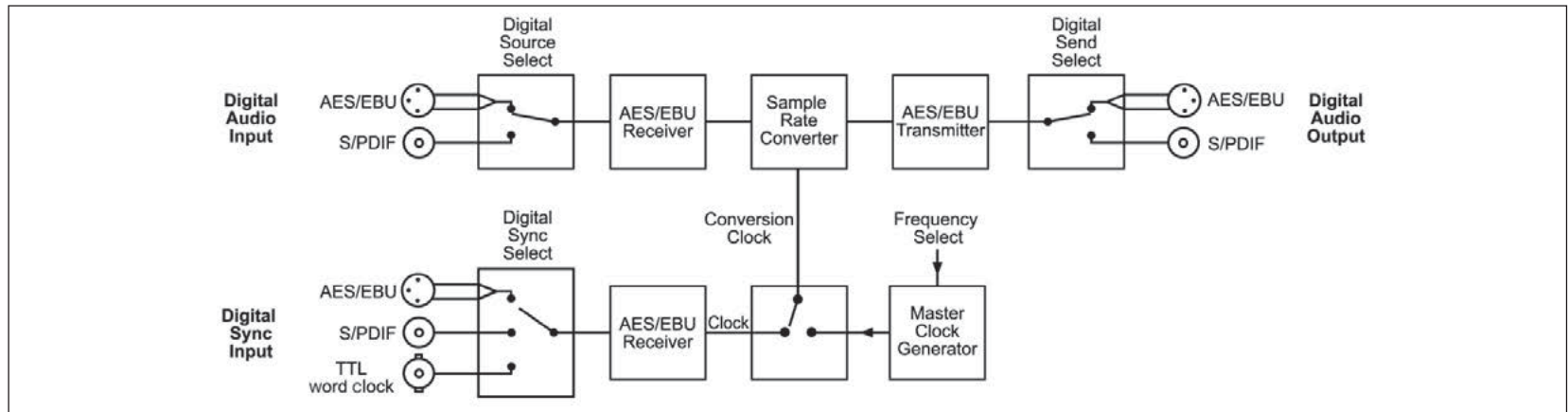



## RB-SC2 Dual Sample Rate Converter



**Category:** Digital Audio Converters.

**Description:** Dual Sample Rate Converter (24 bit, 192kHz Capable).

**Product Function:** Transferring digital audio between digital equipment.

**Typical Applications:** Converting an audio library from 44.1kHz to 48kHz, transferring digital audio from a recorder at 48kHz to a digital mixer at 192kHz.

The RB-SC2 sample rate converter is a 1U rack-mount which produces AES/EBU, S/PDIF and Toslink optical level digital audio outputs from a balanced AES/EBU, S/PDIF and Toslink optical level digital audio inputs. The sample rate of the outputs can be set by an internal clock or from various external synchroniser sources.

The RB-SC2 is a high performance, enhanced version of the RB-SC1 providing the following additional features:

- It supports higher sample frequency rates up to and including 176.4kHz and 192kHz.
- It has 2 independent sample rate converter circuits that use a common clock source to set the output sample rate.
- It has 2 optional video synchronising boards. These set the output sample rate to 48kHz that is synchronised to either an analogue video signal or SDI digital video signal (HD or SD).
- A special X-Lock mode allows the unit to function as a full bi-directional sample rate converter.
- It has Toslink optical digital audio inputs and outputs.
- It has front panel push-button switches for all the main settings. The buttons are arranged in sets, where pressing the button advances the current selection and LED indicator.

- A serial RS232 port is included so that the RB-SC2 settings can be controlled remotely. The front panel LED indicators alter automatically when using RS232 commands.

For the digital outputs, there are three push-button switches to select the sample frequency (FREQUENCY), channel status bit type (CSDATA), and sync source and mode of operation (SYNC).

The FREQUENCY button allows selection of the master sample frequency from one of 32kHz, 44.1kHz, 48kHz, 88.2kHz, 96kHz, 176.4kHz or 192kHz. The CS DATA button defines the content of the channel status bits embedded within the digital audio stream, and can be forced to either Professional Mode (PRO), Consumer Mode (CON) or to follow the mode of the input (FOLLOW).

The SYNC button is used to select the synchronisation input, from the AES/EBU sync input, the Wordclock input or, for X-Lock, the other digital input. The X-Lock synchronisation allows the unit to act as a bi-directional sample rate converter with the output of sample rate converter 1 syncing the input of sample rate converter 2 and vice versa so that they follow each other.

The application for the X-Lock mode is so that the RB-SC2 can be inserted between 2 digital devices which run at different sample rates, such as a PC recorder and a digital player. Using the RB-SC2 in X-Lock mode ensures that the 2 devices remain synchronised at all times regardless of the sample rate of the 2 devices.

The SYNC button will also select the operating mode of the unit as described below. If an optional video sync board is fitted then 2 sync LEDs light together to show the active video sync.

**Master Mode** - In this mode the unit receives a digital audio signal, which is passed to the sample rate converter and then re-formatted for the digital serial transmitter (IEC958). The sample rate converter clock signal is generated internally from an on board master clock at a selectable rate (32kHz, 44.1kHz, 48kHz, 88.2kHz, 96kHz, 176.4kHz or 192kHz).

**Slave Mode** - In this mode the unit is synchronised to an external source, using the digital audio sync, or to the TTL level Word Clock. The FREQUENCY LED will indicate the synchronised sample frequency and if no sync is present, no output will be generated.

**Auto Mode** - Here, the unit is synchronised to an external source, using the digital





RB-SC2 shown with optional synchronisation board.

audio sync, or to the TTL level Word Clock. If no sync signal is present the unit runs from the onboard master clock at a rate selected by the front panel control (32kHz, 44.1kHz, 48kHz, 88.2kHz, 96kHz, 176.4kHz or 192kHz).

**Auto Lock Mode** - This operates like the auto mode except that if no sync signal is present the unit will run at the closest master clock rate to the last locked incoming signal. The FREQUENCY LED will indicate the synchronised sample frequency.

When operating in sync modes, the SYNC button flashes whenever the unit is not synchronised to the incoming sync signal.

There are 2 further push-button switches (INPUT 1 & INPUT2) that are used to select the input connector used for each of the 2 sample rate converter circuits. These switches select between AES/EBU, S/PDIF and TosLink optical connectors.

A red LED indicates power to the RB-SC2.

### Specification For RB-SC2

#### Audio Specification

Dynamic Range:	138dB typical A-Weighted.
Distortion & Noise:	-134dB THD + N at 1kHz, ref 0 dBFS
Sample Freq Range:	32kHz – 196kHz
Input Sample Width:	Up to and including 24 Bits.
Output Sample Width:	24 Bits.

#### Connections

Digital Inputs:	2 x AES/EBU XLR 3 pin female 2 x S/PDIF RCA phono 2 x TosLink optical input
Digital Outputs:	2 x AES/EBU XLR 3 pin plug 2 x S/PDIF RCA phono socket 2 x TosLink optical output
Sync Inputs:	1 x AES/EBU XLR 3 pin female 1 x Word Clock BNC 1 x Video Input (optional)

Video Sync Specs:	The Digital video sync board will accept 270Mbps SD-SDI and HD-SDI signals covered by SMPTE-259-M-C (SD) and SMPTE-292M (HD). The Analogue video sync board
-------------------	--

will accept a composite signal of NTSC (525), PAL (625) & SECAM (625) signals covered by SMPTE-170-M (NTSC) and ITU-R BT.470-6 (PAL & SECAM).

#### Operational Controls

Master Frequency Select:	32, 44.1, 48, 88.2, 96, 176.4 or 192kHz via FREQUENCY push-button
Channel Status Bits:	Consumer mode, professional mode or follow input, via CS DATA push-button
Digital Select:	AES/EBU, S/PDIF or TosLink Input optical, via INPUT1 or INPUT2 push-buttons
Sync Input Select:	AES/EBU, Word Clock, X-Lock or Video, via SYNC push-button
Sync Mode Select:	Master, slave, auto or auto lock, via SYNC push-button

#### Other Connections

Main Input:	Universal filtered IEC, continuously rated 85-264VAC @47-63Hz, max 10W
Fuse Rating:	Anti-surge fuse 1A 20 x 5mm
Serial Port:	RS232 9 Pin D-type socket

#### Equipment Type

RB-SC2:	Dual Stereo Sample Rate Converter, 24 bit 192kHz
---------	--

#### Physical Specifications

Dimensions (Raw):	48cm (W) x 10.8cm (D*) x 4.2cm (H) (1U) 19" (W) x 4.3" (D*) x 1.7" (H) (1U)
Dimensions (Boxed):	59cm (W) x 27.5cm (D) x 11cm (H) 23.2" (W) x 10.8" (D) x 4.3" (H)
Weight:	Nett: 1.4kg Gross: 2.0kg Nett: 3.1lb Gross: 4.4lb

#### Accessories

RB-SYA:	Analogue video sync board (NTSC, PAL & SECAM)
RB-SYD:	Digital video sync board (SD-SDI & HD-SDI)
RB-RK3:	1U Rear panel rack kit for large Redboxes

Note that this product is deeper than standard Redboxes



## RB-DAC1 Digital To Analogue Converter



**Category:** Digital Audio Converters.

**Product Function:** Converts a digital audio signal to an analogue signal.

**Typical Applications:** To connect the output of a CD player to an analogue amplifier, or the program output of a digital mixer to a pair of powered speakers.

**Features:** AES/EBU & S/PDIF digital inputs, headphone amplifier, configurable full-scale settings.

Using 24 bit, 96kHz capable devices, the RB-DAC1 D/A Converter is a 1U rack-mount which produces a stereo balanced XLR or unbalanced phono output from an incoming AES/EBU or S/PDIF digital input signal. There is also a headphone output with volume control for monitoring purposes.



The analogue outputs have an output level control, allowing full-scale settings selectable from +12dBu, +18dBu or +24dBu. The RCA phono outputs have a further 8.5dBu attenuation incorporated.

There is a button to select either the AES/EBU or S/PDIF input for the D/A converter, which is located on the rear panel.

Additionally, if de-emphasis is selected, the RB-DAC1 will decode 50/15µs emphasis when indicated by certain channel status bits in the incoming digital audio data.

When operating, the front panel power LED flashes whenever the unit is not synchronised to the incoming digital signal.

### Specification For RB-DAC1

#### Audio Specification

Maximum Output Level:	+24dBu balanced, +14dBu unbalanced +12dBu headphone
Output Impedance:	<50Ω balanced, <75Ω unbalanced
Dynamic Range:	>100dB
Gain Range:	Selectable 12dBu, 18dBu or 24dBu output level, ref FSD
Headphone Output:	Drives 150mW into 32Ω to 600Ω professional headphones
Distortion & Noise:	<0.01% THD + N @1kHz, ref 0dBu
Sample Freq. Range:	30kHz - 100kHz

#### Operational Controls

Digital Input Select:	AES/EBU or S/PDIF, via push-button
Gain Select:	DIP switch
De-emphasis On/Off:	DIP switch

#### Connections

Digital Inputs:	1 x AES/EBU XLR 3 pin female 1 x S/PDIF RCA phono
Analogue Outputs:	2 x XLR 3 pin male (balanced) 2 x RCA phono (unbalanced)
Headphone Output:	1 x ¼" (6.35mm) A/B-gauge 3-pole stereo jack sockets
Mains Input:	Filtered IEC, 110V-120V, or 220-240V, fused, 10W max
Fuse Rating:	Anti-surge fuse 100mA 20 x 5mm (230VAC) Anti-surge fuse 250mA 20 x 5mm (115VAC)

#### Equipment Type

RB-DAC1:	Digital to analogue converter
----------	-------------------------------

#### Physical Specification

Dimensions (Raw):	48cm (W) x 10.8cm (D) x 4.2cm (H) (1U) 19" (W) x 4.3" (D) x 1.7" (H) (1U)
Dimensions (Boxed):	58.5cm (W) x 22.5cm (D) x 7cm (H) 23" (W) x 8.9" (D) x 2.8" (H)
Weight	Nett: 1.4kg Gross: 2.0kg Nett: 3.1lbs Gross: 4.4lbs



## Synchronisation Add-On Boards

There are four optional synchronisation boards which can be used with the RB-SC2 and RB-TGHD(B & X) to synchronise the outputs to analogue video (RB-SYA), digital video (RB-SYD), AES/EBU audio (RB-SYE) and word clock (RB-SYW) respectively.

### RB-SYA Analogue Video Sync Board

The Analogue video sync board will accept a composite signal of NTSC (525), PAL (625) & SECAM (625) signals covered by SMPTE-170-M (NTSC) and ITU-R BT.470-6 (PAL & SECAM).



RB-SYA Analogue Video Sync Board For RB-SC2 (PAL, NTSC, SECAM).

### RB-SYD Digital Video Sync Board

The Digital video sync board will accept 270Mbps SD-SDI and HD-SDI signals covered by SMPTE-259-M-C (SD) and SMPTE-292M (HD).



RB-SYD Digital Video Sync Board For RB-SC2 (HD-SDI, SD-SDI).

### RB-SYE Audio Sync Board

The AES/EBU sync board can be used to synchronise the outputs of the RB-TGHD(B & X) and can accept a digital audio input signal with a sample frequency between 32kHz and 192 kHz. When using the RB-SYE sync board, the Channel Status information that is encoded in the input data signal is copied to all digital output channels on the RB-TGHD.



RB-SYE AES/EBU Sync Board.

### RB-SYW Word Clock Sync Board

The Word Clock sync board will accept a distributed clock running at the desired sample frequency between 32 kHz and 192 kHz. The signal can be differential or single ended TTL level.



RB-SYW Word Clock Sync Board For RB-TGHD.



**Category:** Synchronisation Add-On Boards.

**Product Function:** Allows the RB-SC2 and RB-TGHD(B & X) to be synchronised to various inputs.

**Typical Applications:** To sync the products to an analogue video sync input, or AES/EBU, or Word Clock.



## RB-DS2R Remote Switch Panel For RB-DS2



**Category:** Synchronisers, Delays & Silence Detectors.

**Product Function:** Remote control unit

for up to 4 x RB-DS2 units.

**Typical Applications:** Remote control of multiple RB-DS2 units from another location, where quick delay time changes are needed.

**Features:** Quick and simple control of delay times in frames from 0 to 7

The RB-DS2R is a remote panel for controlling up to 4 separate RB-DS2 units from a single 1U 19" rack-mount panel.

The unit has 4 rotary switches, each with 8 available selections numbered 0 to 7, used for selecting the delay time in frames.

On the rear of the unit are 4 x 15-way D-type connectors used for connecting directly to the remote input of 4 x RB-DS2 units.

The RB-DS2R is a passive unit, i.e. there is no power supply.

### Specification For RB-DS2R

#### Audio Specification

#### Rear Panel Connections

Remote I/O Port: 4 x 15-way 'D'-type socket, 8 GPI outputs

#### Front Panel Controls

Selector Switches: 4 x 8 way rotary selectors

#### Equipment Type

RB-DS2R: Remote switch panel for 4 x RB-DS2

#### Physical Specification

Dimensions (Raw): 48cm (W) x 10.8cm (D) x 4.2cm (H) (1U)  
19" (W) x 4.3" (D) x 1.7" (H) (1U)

Dimensions (Boxed): 58.5cm (W) x 22.5cm (D) x 7cm (H)  
23" (W) x 8.9" (D) x 2.8" (H) Weight

Weight: Nett: 1.2kg Gross: 1.6kg  
Nett: 2.6lbs Gross: 3.5lbs







## RB-DS2 Stereo Delay Synchroniser & Time-Zone Delay



**Typical Applications:** In the broadcast chain to remove lip-sync errors, post production to synchronize audio when monitoring video signals, time zone delay to provide +1 hour programme feed.

**Features:** Analogue and digital I/O. Can be used as a fixed delay or for correction on the fly. Memory expansion option offers delay times in excess of 4 hours. 8 GPI's offer remote access/switching of pre-set delays.

**Category:** Synchronisers, Delays & Silence Detectors.

**Product Function:** Resynchronisation of audio to video (lip-sync) following conversion, transmission delay & network delays.

The RB-DS2 is a stereo audio delay synchroniser used for resynchronising audio to video following delay processes such as standards conversion, transmission delay, logo insertion, video aspect ratio conversion and network delays.

It can be used for fixed installations to correct a permanent audio delay, or on an intermittent basis to provide occasional correction, for example for live links.

Accepting digital audio signals up to 96kHz, 24 bit, the sonic quality of the RB-DS2 is superb and silent switching is used to provide the smoothest, cleanest audio delay available.

The RB-DS2 has both balanced analogue and AES/EBU digital audio inputs and outputs on 3 pin XLR connectors. It can act as a combined A/D and D/A unit meaning that analogue inputs can be delayed and output as AES/EBU or vice-versa. It is a stereo delay, but can also be used as a dual mono delay, to process each audio path separately, or as a mono delay only.

As standard the RB-DS2 can provide up to 10.5 seconds of delay at 96kHz sampling, 24 bit (42 secs at 48kHz, 16 bit). An internal Compact Flash™ expansion allows up to 2GB of memory to be accessed providing delay times of over 4 hours, for example, to delay a programme output across different time-zones, or to shift a broadcast programme by 1 hour for a satellite rebroadcast. Delay times can be selected in samples, fields, frames, metres, milliseconds and with the Compact Flash™ expansion, in hh:mm:ss. Frame and field definitions can be for PAL (25 frame) or NTSC (30 frame) signals.

A front panel blue vacuum fluorescent display with rotary controller is used for selecting the various settings of the delay, which include the source (analogue or digital), channels, sample rate, sample bit width, format (PAL or NTSC), delay units and the delay itself. Additionally, input peak

digits can be selected from +12dBu, +18dBu and +24dBu for FSD and two left and right pre-set potentiometers on the rear panel allow the input gain range to be altered by ±3dB around the selected peak digits.

The analogue output gain range can be altered in software from -6dBu to +24dBu output level, ref FSD.

Both analogue and digital outputs can be separately muted and a front panel Bypass button disengages electro-mechanical relays to divert both analogue and digital inputs to their outputs. This is also disengaged automatically when a power-fail occurs.

All of the settings in the unit can be saved to one of 8 configuration settings. These Configs can be viewed, edited, saved and loaded, and also remotely loaded by using one of the 8 GPI contacts, meaning that any setting, such as delay time or Bypass, can be altered instantaneously using a GPI signal.

The RB-DS2 also has an RS232 serial port for remotely controlling the unit and there are 4 remote outputs which can be used for signalling. The front panel controls can be locked-out for situations where remote control is being used to run the unit, or where physical security is required.

### Specification For RB-DS2

#### Audio Specification

A/D Specification	
Maximum Input Level:	+28dBu
Input Impedance:	> 10kΩ bridging
Analogue & Digital Input Levels:	Selectable +12dBu, +18dBu, +24dBu for FSD
Analogue Pre-set Input Gain Range:	Adjustable 3dB loss to 3dB gain (L & R adjust)
Signal to Noise:	Better than -101dBFS (RMS A-weighted at 24bit)
Dynamic Range:	> 110dB
Distortion & Noise:	> 96dB THD + N at 1kHz

#### D/A Specification

Maximum Output Level:	+24dBu
Output Impedance:	< 50Ω
Dynamic Range:	> 100dB
Analogue Output Gain Range:	Selectable -6dBu to +24dBu output level, ref FSD
Sampling Frequency:	Selectable 32kHz, 44.1kHz, 48kHz, 64kHz, 88.2kHz or 96kHz
Sample Width:	Selectable 16bit or 24bit
Channels:	Stereo or dual mono
Format (Fields & Frames):	PAL, NTSC
Delay Units:	Samples, fields, frames, milliseconds, hh:mm:ss, (with CF expansion)
Maximum Delay:	10.5 seconds @ 96kHz, 24bit, stereo (excluding memory expansion)

#### Rear Panel Connections

Analogue Inputs:	2 x XLR 3 pin female (balanced) (L & R)
Analogue Outputs:	2 x XLR 3 pin male (balanced) (L & R)
Digital Inputs:	1 x AES/EBU XLR 3 pin female
Digital Outputs:	1 x AES/EBU XLR 3 pin male
Remote I/O Port:	15-way 'D'-type plug, 8 GPI inputs, 4 GPI outputs
Serial Comms Port:	9-way 'D'-type plug
Memory Expansion:	Internal Compact Flash™ storage card supporting up to 2GB. CF cards must be PIO Type 4 or higher.
Mains Input:	Filtered IEC, continuously rated 85-264 VAC, 47-63Hz, fused, 60W peak, 30W average

Fuse Rating: Anti-surge fuse 2A 20 x 5mm

#### Front Panel Controls

Display:	Vacuum fluorescent display
System Navigation:	Rotary selector with integral push-switch
Audio Bypass:	Via push-button

#### Equipment Type

RB-DS2:	Stereo delay synchroniser & time-zone delay
---------	---

#### Physical Specification

Dimensions (1U)	48cm (W) x 15.8cm (D*) x 4.2cm (H)
(Raw):	19" (W) x 6.2" (D*) x 1.7" (H) (1U)
Dimensions (Boxed):	59cm (W) x 27.5cm (D*) x 11cm (H)
(Boxed):	23.2" (W) x 10.8" (D*) x 4.3" (H)
Weight:	Nett: 1.6kg Gross: 2.3kg Nett: 3.5lbs Gross: 4.8lbs

\* Note that this product is deeper than standard Redboxes



## RB-PD2 Stereo Profanity Delay



**Category:** Synchronisers, Delays & Silence Detectors.

**Product Function:** To introduce an audio delay into a program output allowing unsuitable or profane program material to be removed instantly.

**Typical Applications:** Radio and TV phone in programs and chat shows where content needs to be censored.

**Features:** Both analogue and digital audio I/O, automatic audio stretch algorithm allows seamless building of the delay, no pitch changes, up to 55 seconds of delay, Drop and Dump buttons, Dump via jingle playout or dropping of audio, GPI control of buttons, GPIO can follow current delay time.

The RB-PD2 is a stereo audio profanity delay used for live broadcast programs to prevent unwanted or obscene material from being transmitted. It features an automatic audio stretch algorithm that allows between 2 and 55 (\*) seconds of delay to be built up live whilst "on air", whilst maintaining the correct pitch. The delay can also be acquired whilst playing a pre-selected audio file on a Compact Flash™ memory card. When the program is complete, the audio stretch algorithm seamlessly reduces the delay to zero.

The RB-PD2 has both balanced analogue and AES/EBU digital audio inputs and outputs on 3 pin XLR connectors and provides sample rates up to 48kHz at 24 bit. It can act as a combined A/D and D/A unit meaning that analogue inputs can be output as AES/EBU or vice-versa.

The delay can be initiated by pressing the BUILD DELAY button on the front panel. A front panel display shows the amount of delay being built-up, up to the amount initially selected.

There are several ways to make sure that any unwanted material is removed from the audio at the outputs. A COUGH function, activated from a dedicated front panel button, allows locally generated sounds being presented at the inputs, such as the presenter coughing or equipment switching noises, to be discarded.

The DUMP function, which is also activated from a front panel button, has 2 different modes. The first DUMP mode removes a section of audio that has already been buffered, by a pre-selected amount. The second DUMP mode plays a pre-selected audio file on the Compact Flash™ memory card. When the file has finished playing, the delay is then equal to the duration of the file. The DUMP button can be used multiple times to use up the built-up delay and once used, the unit automatically starts to rebuild the original delay time.

As a last resort, all the buffered audio can be discarded by pressing and holding the DUMP button which activates the DROP function.

At the end of a radio show when you want to broadcast live, the delay can be ramped down by pressing the front panel EXIT DELAY button.

A dedicated record mode allows audio presented at either the analogue or digital inputs to be recorded to a linear WAV file on a Compact Flash™ memory card. Additionally, the card format used is PC readable, allowing pre-recorded linear WAV

files to be transferred easily from a PC or other such device.

A front panel blue vacuum fluorescent display with rotary controller is used for selecting the various settings of the profanity delay, which include the start delay and dump modes, safe period, source (analogue or digital), sample rate and sample bit width as well as the required delay time. The current delay value, in seconds, is permanently displayed as is the current status of the unit. Additionally, input peak digits can be selected from +12dBu, +18dBu and +24dBu for FSD and two left and right pre-set potentiometers on the rear panel allow the input gain range to be altered by ±3dB around the selected peak digits. The analogue output gain range can be altered in software from -6dBu to +24dBu output level, ref FSD. Both analogue and digital outputs can be separately muted and a front panel Bypass button disengages electro-mechanical relays to divert both analogue and digital inputs to their outputs. This is also disengaged automatically when a power-fail occurs.

The RB-PD2 features a remote port supplying 8 inputs and 6 outputs, all of which are freely assignable. The inputs can be used to trigger any of the unit's functions such as build delay, activate cough or enter record mode and start a new recording. The outputs can provide external signalling to indicate when certain events have occurred such as the delay reaching the required value or the outputs being muted. Also,

the 6 remote outputs can optionally be made to follow 6 of the inputs with the current programme delay inserted between actuation on the input and actuation on the output. This can be useful for timed events that need to account for the delay built up by the RB-PD2.

Because playback from a Compact Flash™ card can be triggered remotely, the RB-PD2 can also be used at transmitter sites to play an emergency audio file via GPI in the event of silence detection.

The front panel controls can be locked-out for situations where remote control is being used to run the unit, or where physical security is required.

A red LED indicates when power to the RB-PD2 is on.

\* At 32kHz 16bit

### Specification For RB-PD2

A/D Specification	
Maximum Input Level:	+28dBu
Input Impedance:	> 10kΩ bridging
Analogue & Digital Levels:	Selectable +12dBu, +18dBu, Input +24dBu for FSD
Analogue Pre-set Input Gain Range:	Adjustable 3dB loss to 3dB gain (L & R adjust)
Signal to Noise:	Better than -101dBFS (RMS A-weighted at 24bit)
Dynamic Range:	> 110dB
Distortion & Noise:	> 96dB THD + N at 1kHz
D/A Specification	
Maximum Output Level:	+24dBu
Output Impedance:	< 50Ω
Dynamic Range:	> 100dB
Analogue Output Gain Range:	Selectable -6dBu to +24dBu output level, ref FSD

Sampling Frequency:	Selectable 32kHz, 44.1kHz or 48kHz
Sample Width:	Selectable 16bit or 24bit
Channels:	Stereo
Minimum Delay:	2 seconds
Maximum Delay:	Dependent on sample and bit rates selected: <b>32kHz:</b> 16 bit - 55 seconds 24 bit - 27.5 seconds <b>44.1kHz:</b> 16 bit - 40 seconds 24 bit - 20 seconds <b>48kHz:</b> 16 bit - 37 seconds 24 bit - 18.5 seconds

Rear Panel Connections	
Analogue Inputs:	2 x XLR 3 pin female (balanced) (L & R)
Analogue Outputs:	2 x XLR 3 pin male (balanced) (L & R)
Digital Inputs:	1 x AES/EBU XLR 3 pin female
Digital Outputs:	1 x AES/EBU XLR 3 pin male
Remote I/O Port:	15-way 'D'-type plug, 8 GPI inputs, 6 GPI outputs
Serial Comms Port:	9-way 'D'-type plug
Mains Input:	Filtered IEC, continuously rated 85 - 264VAC, 47 - 63Hz, fused, 60W peak, 30W average
Fuse Rating:	Anti-surge fuse 2A 20 x 5mm

Front Panel Controls	
Display:	Vacuum fluorescent display
Direct Control Push-Buttons:	Build Delay, Exit Delay, Cough, Audio Bypass & Dump/Drop
System Navigation:	Rotary selector with integral push-switch
Removable Audio Storage Device:	Compact Flash™ memory card port (supporting up to 2GB) CF™ card used must be PIO type 4 or higher

Equipment Type	
RB-PD2:	Stereo profanity delay
Physical Specification	
Dimensions (Raw):	48cm (W) x 15.8cm (D*) x 4.3cm (H) (1U) 19" (W) x 6.2" (D*) x 1.7" (H)(1U)
Dimensions (Boxed):	59cm (W) x 27.5cm (D*) x 11cm (H) 23.2" (W) x 10.8" (D*) x 4.3" (H)
Weight :	Nett: 1.7kg Gross: 2.3kg Nett: 3.7lbs Gross: 5lbs

\* Note that this product is deeper than standard Redboxes





## RB-DD4 4 Channel Digital Audio Delay



**Typical Applications:** In the broadcast chain to remove lip-sync errors, post production to synchronize audio when monitoring video signals, time zone delay to provide +1 hour programme feed.

**Category:** Synchronisers, Delays & Silence Detectors.

**Product Function:** Resynchronisation of audio to video (lip-sync) following conversion, transmission delay & network delays.

**Features:** Digital I/O as AES/EBU, S/PDIF or TOSlink; delays 4 channels independently, front panel headphone monitoring, audio presence display, remote operation with SCi software, passive signal path and can be used as a fixed delay or for correction on the fly.

The RB-DD4 4 channel digital audio delay allows you to delay 4 mono channels of audio independently or together. Each channel delay is user selectable from multiples of common video frame rates, or a user defined value set via the serial interface. The unit is perfect for synchronizing audio to video which has been delayed by processing latency.

Using a front panel button, you can select which channel needs to be delayed. There is also an 'ALL' option which allows the selected delay to be applied to all channels. Then using another front panel button you

can select the length of one frame of delay and the multiple of frames to delay by.

The connectivity is incredibly flexible, allowing three different types of connection to each input and output including AES/EBU, S/PDIF and TOSLink. All three different types of output can be used simultaneously. There is a monitor socket on the front panel which allows you to listen to each mono channel, by front panel selection. Pairs of channels can be monitored (1 & 2 or 3 & 4) using a rear panel stereo option. There is also an option to attenuate the monitor by 12dB selectable by rear panel DIPswitch. Audio presence is detected and displayed for each channel



RB-DD4 4 Channel Digital Audio Delay (With RB-SYD Video Sync Board).





around the INPUTS 1 & 2 and INPUTS 3 & 4 buttons.

The flexibility continues with many audio synchronization options. The digital audio output can be synchronized to either input, an additional AES/EBU reference input, a TTL wordclock BNC input or an analogue/SDI video feed if used with an additional RB-SYA or RB-SYD board. Also the output can be synchronized to an on-board master clock, with a selectable frame rate. There are warning indicators on the front panel for loss of lock on both inputs and for the selected external synchronization. Selectable synchronization modes are as follows:

**Master Mode** - In this mode the digital output sample rate is simply set by, and locked to, the internal on-board clock generator. No sync signal is used or required.

**Auto Sync Mode** - In this mode the digital output sample rate follows the selected sync input. When the sync signal is not present the output sample rate will be set by, and locked to, the internal on-board clock generator at the selected output frequency.

**Auto Lock Mode** - The digital output sample rate follows the sync input. If the sync signal is removed then the output sample rate will be set by, and locked to, the internal on-board clock generator at the closest frequency available to the previous sync input.

**Slave Mode** - In this mode the digital output sample rate follows the sync input. When the sync signal is not present the digital output is turned off.

A powerful feature of the RB-DD4 is that by using the Sonifex SCI serial software, the unit can be programmed for different delay durations, levels and switching functions so that you can program the unit for your specific application. A rear panel DIPswitch configures the unit to be controlled serially. Contact Sonifex for further information if you have a particular requirement that isn't catered for by the RB-DD4 as standard.

The RB-DD4 has been designed to have a passive signal path through the main input, so if power to the unit fails, signal inputs 1 & 2 are routed to outputs 1 & 2 and signal inputs 3 & 4 are routed to outputs 3 & 4. This is essential for applications such as installation at transmitter sites, where a power failure to the unit should not prevent the audio input signal from being output to the transmitter. Please note that this is not true for the TOSLink outputs which are muted.

### Specification For RB-DD4

Audio Specification	
Dynamic Range:	>138dB
Distortion and Noise:	<-137dB THD + N at 1kHz, ref 0dB FS
Input & Output Impedances:	110Ω ±20% AES/EBU balanced I/O 75Ω ±5% S/PDIF unbalanced I/O 75Ω ±5% TOSlink unbalanced I/O 50Ω BNC TTL word clock input
Signal Level:	Balanced: 3V/10V peak to peak min max Unbalanced: Min 0.5V±20% peak to peak
Sample Freqs:	32, 44.1, 48, 88.2, 96, 176.4 or 192kHz
Bit Depth:	Up to and including 24 bit
Max Delay:	8 secs per mono channel at 32kHz 1.33 secs per mono channel at 192kHz
Frame Rates (Front Panel):	23.98fps, 24fps, 25fps, 29.97fps, 30fps, 50fps, 59.94fps, 60fps
Frame Rates (SCI Software):	525/29.97, 625/25, 720/60p, 720/59.94p, 720/50p, 720/30p, 720/29.97p, 720/25p, 720/24p, 720/23.98p, 1035/60i, 1035/59.94i, 1080/60i, 1080/59.94i, 1080/50i, 1080/30p, 1080/29.97p, 1080/25p, 1080/24p, 1080/23.98p, 1080/30p5F, 1080/29.97p5F, 1080/25p5F, 1080/24p5F, 1080/23.98p5F, 1080/60p, 1080/59.94p, 1080/50p
Delay Settable:	1 to 19 frames (front panel controls) Frames, lines, fields, milliseconds and samples up to total delay time (SCI software)
Front Panel Operational Controls & Indicators	
Digital Input Select:	AES/EBU, S/PDIF or TOSlink optical via INPUTS 1 & 2 or INPUTS 3 & 4 push-buttons
Delay Control:	Delay time selection system via front panel push button
Monitor Select Control:	Headphone monitor channel select
Indicators:	Input presence indicators via bicolour LEDs around each push button
Rear Panel Operational Controls	
Master Select:	32, 44.1, 48, 88.2, 96, 176.4 or 192kHz Frequency via rear panel DIPSwitches
Sync Source Select:	INPUTS 1&2, INPUTS 3&4, AES Sync, Word Clock, Video Sync via rear panel DIPSwitches

Sync Mode Select:	Master, Auto Sync, Auto Lock, Slave via rear panel DIPSwitches
Stereo Features:	Stereo monitor outputs via rear panel DIPSwitches
Monitor Attenuation:	12dB monitor attenuation via rear panel DIPSwitches
Serial Mode:	Enter serial control mode via rear panel DIPSwitches
Boot Mode:	Boot up base code or firmware via rear panel DIPSwitches
Connections	
Digital Inputs:	2 x AES/EBU XLR 3 pin female 2 x S/PDIF RCA phono 2 x TOSLink optical input
Digital Outputs:	2 x AES/EBU XLR 3 pin plug 2 x S/PDIF RCA phono socket 2 x TOSLink optical output
Sync Inputs:	1 x AES/EBU XLR 3 pin female 1 x Word Clock BNC 1 x Video Input (optional)
Remote I/O Port:	15 way D-type plug
Serial Port:	RS232, 9 pin D-type socket
Mains Input:	Universal filtered IEC, continuously rated 85-264VAC@47- 63Hz, max 10W
Fuse Rating:	Anti-surge fuse 2A 20 x 5mm
Equipment Type	
RB-DD4:	4 channel digital audio delay
Physical Specifications	
Dimensions (Raw):	48cm (W) x 10.8cm (D*) x 4.2cm (H) (1U) 19" (W) x 4.3" (D*) x 1.7" (H) (1U)
Dimensions (Boxed):	59cm (W) x 27.5cm (D*) x 11cm (H) 23.2" (W) x 10.8" (D*) x 4.3" (H)
Weight:	Nett: 1.4kg Gross: 2.0kg Nett: 3.1lb Gross: 4.4lb
Accessories	
RB-SYA:	Analogue video sync board (NTSC, PAL & SECAM)
RB-SYD:	Digital video sync board (SD-SDI & HD-SDI)
RB-RK3:	1U Rear panel rack kit for large Redboxes

\* Note that this product is deeper than standard Redboxes



## RB-AEC Acoustic Echo Celler



**Category:** Synchronisers, Delays & Silence Detectors.

**Product Function:** Remove acoustic echo in a presenter's earpiece caused by microphones picking up audio from loudspeakers in delay.

**Typical Applications:** In a TV production environment where presenters are fed a signal which has some form of acoustic delay or echo. Any situation where adaptive echo cancellation is required.

**Features:** Built-in web server interface, analogue and digital I/O, automatic operation once configured.

The RB-AEC 1U rack-mount is an acoustic echo canceller primarily designed for the benefit of studio personnel for television and radio. When a studio presenter's microphone signal is played out through a monitor speaker in the control room, it can be picked up by the control room microphone(s) and returned to the presenter's earpiece as an undesirable echo.

In circumstances where green screen video processing is taking place, the delay can be greater than 200ms. Additionally, the dimensions, occupancy and distance between mouth and microphone can further

influence the echo. The RB-AEC is used to remove the entire control room monitor speaker output from the presenter's feed by adapting to the environment in which the control room microphones are placed. Although acoustic echo cancellation is more commonly implemented in telephony systems, the Sonifex RB-AEC is designed to produce broadcast quality cancellation.

Much like during a conference call configuration between two rooms, each room has a microphone and speaker to conduct a conversation. When an occupant of one room speaks, it takes a certain length of time before it is received in the

second room. Without a suitable solution this 'delayed' signal can then be captured by the microphone in the second room and returned back to the first room as an echo.

In the particular example of TV production, as well as the processing/transmission delay, sound reflections from the control room monitor speaker into the control room microphone(s) cause the studio earpiece to suffer further delay. The sound reflections in the control room vary with the contents of the room including any personnel present. Also, different frequencies produce varying reflections across various types of surfaces and magnitudes within the room. For a 15m distance between speaker and microphone the delay is as much as 40ms. The DSP solution offered by the RB-AEC can dynamically compensate for varying configurations.

### Operation of the RB-AEC

The post-processed transmission output program from the studio (A) is sent to the RB-AEC as an analogue or digital audio signal (the stereo input is auto-sensing) which acts as a mix-minus to the input signal (B) from the Control Room. The RB-AEC removes the unwanted acoustic echoes so that the audio sent to the presenter's earpiece (C) is free of echoes and reflection artifacts.

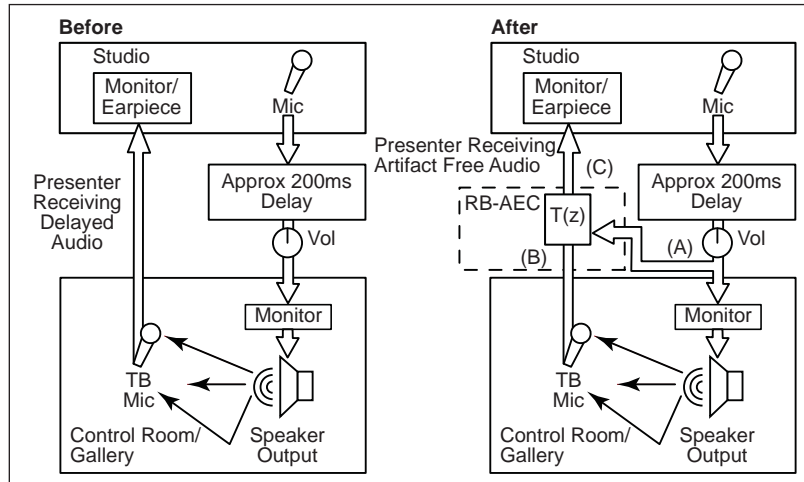



### Specification For RB-AEC

#### Audio Specification

Audio Input (Program):	1 x mono analogue or AES/ EBU digital on XLR 3-pin female (autoselecting)
Audio Input (From Control Room):	1 x mono analogue or AES/EBU digital on XLR 3-pin female (autoselecting)
Max Level (0dB Input Gain):	+18dBu (analogue)/0dBFS (digital)
CMRR:	>60dB typical
Input Impedance:	20kΩ (analogue) 110Ω (digital with termination switchable)
AES/EBU Input:	32kHz to 192kHz
Input Gain:	0, +6, +12 or +18dB digital gain (switchable)
Audio Outputs (Analogue):	2 x mono analogue on XLR 3-pin male
Audio Outputs (AES/EBU):	1 x stereo digital AES/EBU on XLR 3-pin male

Maximum Output Level:	+18dBu (analogue)/0dBFS (digital)
Output Impedance:	<50Ω (analogue)/110Ω (digital)
AES/EBU Output Sample Rates:	Selectable 32kHz - 192kHz
Distortion:	<0.02% (1kHz, +8dBu output)
Noise:	-84dB RMS, unity gain ref +8dBu output
Frequency Response:	20Hz-12kHz +/-0.5dB
Rejection Ratio (Input to Output):	Typically 20dB on complex waveforms, reference peak level of 0dB
Remote I/O Port:	9 way D-Type socket
Ethernet Port:	1 x RJ45 with status LEDs
Mains Input:	Filtered IEC, continuously rated 85 264VAC @ 47-63Hz, 10W max
Fuse Rating:	Anti-surge fuse 1A 20 x 5mm

#### Controls

Configuration:	1 x Ethernet port and 1 x rear panel 4-way dipswitch
Reset:	1 x front panel recessed button

#### Equipment Type

RB-AEC:	Acoustic echo canceller
---------	-------------------------

#### Physical Specification

Dimensions (Raw):	48cm (W) x 10.8cm (D) x 4.2cm (H) (1U) 19" (W) x 4.3" (D) x 1.7" (H) (1U)
Dimensions (Boxed):	58.5cm (W) x 22.5cm (D) x 7cm (H) 23" (W) x 8.9" (D) x 2.8" (H)
Weight:	Nett: 1.5kg Gross: 2.0kg Nett: 3.3lbs Gross: 4.4lbs



## RB-SD1 Silence Detection Unit



**Category:** Synchronisers, Delays & Silence Detectors.

**Product Function:** To detect silence in an analogue audio signal and switch to a second source.

**Typical Applications:** At a radio transmitter site, before the input to the transmitter. A local audio source will become the secondary input in case silence is detected from the studio source. At a radio studio in case of failure of broadcast playout server, it can switch in an emergency playback system.

**Features:** Adjustable silence detect threshold level and silence duration, passive signal path, switching of external equipment on silence detection, automatic or manual operation, mono or stereo operation, front panel LED indications of alarm status.

The RB-SD1 silence detection unit is a 1U rack-mount device used to monitor an unattended stereo studio feed and in the event of the signal going “quiet” after a given period the unit will switch through an alternative stereo audio signal. This signal could be a recorded message (e.g. “normal service will be resumed”, etc), a feed from a CD player or minidisc machine, or an alternative recorded programme. Controls are provided to start external equipment and to provide remote status indication.

It has 2 balanced stereo audio inputs with the maximum input level being +28dBu. Each input is user-defined as either the main source or auxiliary source and both sources are monitored for failure, each having a remote failure alarm. In the event of the main source dropping below a pre-set level for a pre-determined amount of time, the unit will automatically switch through to the auxiliary signal.

The silence detect level is adjustable between -60dBu and -15dBu in 3dB steps via a 16 position rotary switch on the rear panel. The silence interval can be adjusted between 2 seconds to 30 seconds in 2 second steps, or, alternatively, set to 2 minutes 5 seconds also via a 16 position rotary switch on the rear panel. The audio outputs use stereo professional balanced XLR-3 male connectors.

The unit can operate in 2 modes - automatic or manual. In both modes it will automatically switch over to the auxiliary source on detecting silence. When the main signal is again detected it will either return to the main signal automatically or manually depending on the mode chosen. The RB-SD1 has a number of remote operational features. Remote outputs provide separate relay contact closures for failure of the main and auxiliary inputs. You can also control remotely all of the front panel switches for source selection, mode selection and signal Restore. You can remotely start and stop another piece of equipment on alarm failure and main signal Restore respectively. Also, the longest silence time (2min 5sec) can be set remotely, which is useful if you are expecting to broadcast a long silence.

The unit can be configured to alarm when either the left or right channel of the main input source fails, or if the whole stereo signal fails. There are also options to set the remote start output as momentary or latched, to disable switching to the auxiliary input on alarming and to increase the gain on the auxiliary input so that an unbalanced input can be used, for example, from a domestic minidisc player.

Front panel LED indicators show individually left and right programme and alarm

conditions for both the main and auxiliary inputs. The status of the source, mode and alarm state are also shown on the front panel with LED indicators.

Additionally, the RB-SD1 can be programmed for specific applications which can be defined on power-up of the unit. Contact Sonifex for further information if you have a particular requirement. (Refer to the handbook on the website for information on current configurations).

The RB-SD1 has been designed to have a passive signal path through the main input, so if power to the unit fails, the signal input will still be routed through to the output. This is essential for applications such as installation at transmitter sites, where a power failure to the unit should not prevent the audio input signal from being output to the transmitter.



### Specification For RB-SD1

#### Audio Specification

Maximum Input Level:	+28dBu
Maximum Output Level:	+28dBu
Frequency Response:	20Hz - 20kHz ±0.1dB
Gain:	+8dB (for unbal input B - optional)
Distortion:	As input for balanced input, <0.05% ref +8dBu output for unbalanced input
Input Impedance:	>100kΩ balanced
Output Impedance:	As input, except when using unbalanced auxiliary input where output impedance <50Ω
Noise:	<-87dB, unity gain, ref +8dBu output for unbal input

#### Rear Panel Connections and Controls

Inputs (Main & Auxiliary):	4 x XLR 3 pin female (balanced, auxiliary can be unbalanced)
Output:	2 x XLR 3 pin male (balanced)
Remotes:	15 way D-type plug
Alarm Threshold:	-15dBu to -60dBu in 3dB steps via rotary switch
Silence Detect Duration:	2 - 30 seconds in 2 second intervals & 125 second option via rotary switch
Detection Type:	Mono or stereo, via DIP switch
Silence Switch Defeat:	Disable/enable silence switching, via DIP switch
Remote Start:	Latched or momentary, via DIP switch
Mains Input:	Filtered IEC, switchable 110-120V, or 220-240V, fused, 9W max
Fuse Rating:	Anti-surge fuse 100mA 20 x 5mm (230VAC) Anti-surge fuse 250mA 20 x 5mm (115VAC)

#### Front Panel Controls and Indicators

Controls (With Indicators):	Source select, mode select and restore
Indicator:	Program and alarm indicators for left and right source for both main and auxiliary channels

#### Equipment Type

RB-SD1:	Silence detection unit
---------	------------------------

#### Physical Specification

Dimensions (Raw):	48cm (W) x 10.8cm (D) x 4.2cm (H) (1U) 19" (W) x 4.3" (D) x 1.7" (H) (1U)
Dimensions (Boxed):	58.5cm (W) x 22.5cm (D) x 7cm (H) 23" (W) x 8.9" (D) x 2.8" (H)
Weight:	Nett: 1.4kg Gross: 2.0kg Nett: 3.1lbs Gross: 4.4lbs





## RB-SD1IP Silence Detection Unit With Ethernet & USB



**Category:** Synchronisers, Delays & Silence Detectors.

**Product Function:** To detect silence in an analogue audio signal and switch to a second source, or third USB source.

**Typical Applications:** At a radio transmitter site, before the input to the transmitter. A local audio source can become the secondary input in case silence is detected and if this fails, USB audio can play. At a radio studio in case of failure of broadcast playout server, it can switch in an emergency playback system.

**Features:** IP Enabled with web browser control interface, SNMP V1 compatible, trap generation for non-networked hardware via GPIO port, USB playback functionality, adjustable silence detect threshold level and silence duration, passive signal path, switching of external equipment on silence detection, automatic or manual operation, mono or stereo operation, front panel LED indications of alarm status.

The RB-SD1IP silence detection unit is an upgraded version of the existing RB-SD1. The unit is a 1U rack mount device used to monitor an unattended stereo studio feed and in the event of the signal going “quiet” after a given period the unit will switch through an alternative stereo audio signal.

This signal could be a recorded message (e.g. “Normal service will be resumed”, etc), a feed from a flashcard player, audio from a connected USB flash drive or an alternative recorded program. Controls are provided to start external equipment and to provide remote status indication.

### New Features:

The RB-SD1IP offers all of the functionality of the standard RB-SD1 with several extra capabilities. Ethernet connectivity provides the ability to set up and control the unit via a browser based GUI. The network capabilities allow the user to more finely control silence level (-60dBu to 0dBu in 3dBu steps) and silence duration (1 second to 24 hours). You can also remotely lock/unlock the front panel controls on the unit and opt to use either the hardware configured settings or web based settings. In addition to the front panel LEDs the GUI home page offers a real time view of signal levels and alarm statuses.

Using the new browser GUI, left and right channels can be treated independently and remote relay triggers can be configured as one of many events including the new GPIO pins. You can also choose to lock/unlock the use of the remote pins to control the unit and firmware updates can also be performed using the web GUI.

SNMP V1 is implemented so that the unit can be controlled by existing network management systems. The addition of 6 extra GPIO pins to the rear panel allows customisable functionality, including the use of the RB-SD1IP network interface to generate SNMP Traps on behalf of other, non-networked, hardware.

The RB-SD1IP has been fitted with a USB interface on the front panel and can act as a host in two ways. Firstly the USB port can be used to upgrade the firmware on the unit from a USB flash drive. Secondly, such a drive can hold a pre-recorded message which the unit can play out in the event that both main and auxiliary signals fall silent.



RB-SD1IP Home Page.



RB-SD1IP Levels Page.

**Specification For RB-SD11P**

**Audio Specification**

Maximum Input Level:	+28dBu
Input Impedance:	>100kΩ balanced
Maximum Output Level:	+28dBu
Output Impedance:	As input, except when using unbalanced auxiliary input where output impedance <50Ω
Frequency Response:	20Hz - 20kHz ±0.1dB
Gain:	+8dB (for unbal input B-optional)
Noise:	<-93dB, unity gain, ref +8dBu output for unbal input
Distortion:	As input for balanced input, <0.02% @ 1kHz ref +8dBu output for unbalanced input

**Rear Panel Connections and Controls**

Inputs (Main & Auxiliary):	4 x XLR 3 pin female (balanced, auxiliary can be unbalanced)
Output:	2 x XLR 3 pin male (balanced)
Remotes:	15 way D-Type plug
GPIO:	9 way D-Type socket
Alarm Threshold:	-15dBu to -60dBu in 3dB steps via rotary switch 0dBu to -60dBu in 3dB steps via web GUI
Silence Detect Duration:	2 - 30 seconds in 2 second intervals & 125 second option via rotary switch 1 second - 24 hours using web GUI
Detection Type:	Mono or Stereo, via DIP switch Mono, Stereo, or dual mono via web GUI

Silence Switch Defeat:	Disable/enable silence switching, via DIP switch or GUI
Remote Start:	Latched or momentary, via DIP switch or GUI
Ethernet:	10/100Mbps on 1xRJ45 socket with status LEDs
Mains Input:	Filtered IEC, continuously rated 85-264VAC @47-63Hz 10W max
Fuse Rating:	Anti-surge fuse 1A 20 x 5mm (250VAC)
<b>Front Panel Controls and Indicators</b>	
Controls (With Indicators):	Source Select, Mode Select and Restore
Indicator:	Program and Alarm indicators for left and right source for both Main and Auxiliary channels, power indicator
Reset:	Recessed push button
USB Port:	1 x USB A socket

**USB**

The RB-SD11P can act as a host for low powered USB Mass Storage devices in order to playback Audio files as an emergency backup system for when both Main and Auxiliary sources fail.

File System(s):	FAT & FAT32
Supported Audio:	.wav extension (16 bit Stereo PCM @ 48KHz, 24KHz, 12KHz, 44.1KHz, 22.050KHz, 11.025KHz, 32KHz, 16KHz, 8KHz)

Note: Additional Audio support may be added in future updates

**Equipment Type**

RB-SD11P:	Silence Detection Unit With Ethernet & USB
-----------	--

**Physical Specification**

Dimensions (Raw):	48cm (W) x 10.8cm (D) x 4.2cm (H) (1U) 19" (W) x 4.3" (D) x 1.7" (H) (1U)
Dimensions (Boxed):	58.5cm (W) x 22.5cm (D) x 7cm (H) 23" (W) x 8.9" (D) x 2.8" (H)
Weight:	Nett: 1.4kg Gross: 2.0kg Nett: 3.1lbs Gross: 4.4lbs





## RB-DSD1 Digital Silence Detection Unit



**Category:** Synchronisers, Delays & Silence Detectors.

**Product Function:** To detect silence in a digital audio signal and switch to a second source.

**Typical Applications:** At a radio transmitter site, before the input to the transmitter. A local audio source can become the secondary input in case silence is detected.

**Features:** Multiple digital audio I/O formats, adjustable silence detect threshold level and silence duration, passive signal path, switching of external equipment on silence detection, automatic or manual operation, front panel LED indications of alarm status.

The RB-DSD1 digital silence detection unit works in a similar way to the Sonifex RB-SD1 analogue silence detection unit, but has AES/EBU, S/PDIF and Toslink inputs and outputs instead of analogue inputs and output respectively. Designed to switch from one input to another in the event of loss of audio, the unit is ideal at transmitter sites, or after the master output of a studio, to switch in another audio source, or simultaneous broadcast, should a master source fail.

The unit can switch:

- On loss of level of the main input.
- On loss of level on one channel of the main input.
- On loss of synchronisation lock of the main input.

The RB-DSD1 has 2 x digital stereo audio inputs, each one selectable via front panel MAIN and AUX push buttons, from either AES/EBU balanced XLRs, S/PDIF unbalanced phonos or Toslink unbalanced optical inputs. Sample rate converters on each

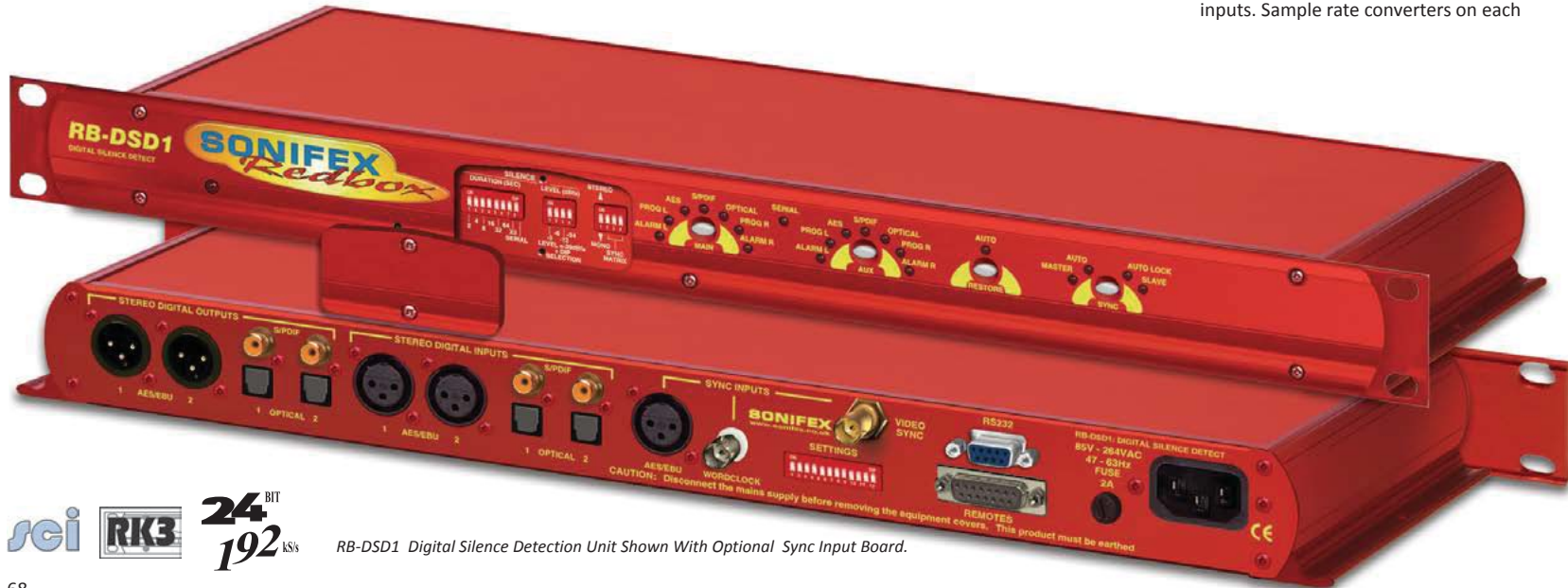

RB-DSD1 Digital Silence Detection Unit Shown With Optional Sync Input Board.

input mean that sources of different sample rates can be used with the output sample rate being defined independently. Each input is user-defined as either the main source or auxiliary source and both sources are monitored for failure, each having a remote failure alarm. The colour of the MAIN and AUX push-buttons indicate which input is the main (green) and auxiliary (red) input, with a flashing LED indicating loss of synchronisation.

In the event of the main source dropping below a pre-set level for a pre-determined amount of time, the unit will automatically switch through to the auxiliary signal. The silence detect level is adjustable between -39dBfs and -84dBfs in 3dBfs steps via front panel DIPswitches. The silence interval can be adjusted between 0 seconds and 252 seconds in 2 second steps via another front panel DIPswitch block. A small cover panel can be screwed in place to obscure the DIPswitches to prevent tampering of the settings.

There are 2 stereo outputs to allow for distribution of the selected input to multiple outputs. Each output is available as simultaneous AES/EBU balanced XLRs, S/PDIF unbalanced phonos or Toslink unbalanced optical outputs. The output sample rates are selectable via rear panel

DIPswitches from one of 32kHz, 44.1kHz, 48kHz, 88.2kHz, 96kHz, 176.4kHz or 192kHz.

The unit has TTL wordclock BNC and AES/EBU XLR synchronising inputs as standard and optionally, the RB-SYA and RB-SYD synchronisation boards can be fitted to synchronise the unit to analogue or digital video signals. A front panel DIPswitch block is used to decide whether the unit is synchronised to Input1, Input2, the AES/EBU sync input, the wordclock sync input or an optional video sync board. A front panel SYNC button selects the synchronisation mode of the unit and the button flashes whenever the unit is not synchronised to an incoming sync signal. Selectable sync modes are as follows:

**Master Mode** - In this mode the digital output sample rate is simply set by, and locked to, the internal on-board clock generator. No sync signal is used or required.

**Auto Sync Mode** - In this mode the digital output sample rate follows the selected sync input. When the sync signal is not present the output sample rate will be set by, and locked to, the internal on-board clock generator at the selected output frequency.

**Auto Lock Mode** - The digital output sample rate follows the sync input. If the sync signal is removed then the output sample rate will be set by, and locked to, the internal on-board clock generator at the closest frequency available to the previous sync input.

**Slave Mode** - In this mode the digital output sample rate follows the sync input. When the sync signal is not present the digital output is turned off.

The unit can operate in 2 modes - automatic or manual, selectable using a rear panel DIPswitch. In both modes it will automatically switch over to the auxiliary source on detecting silence. When the main signal is again detected it will either return to the main signal automatically or manually depending on the mode chosen. In manual mode, the front panel RESTORE button is used to return to the main signal.

The RB-DSD1 has a number of remote operational features. Remote outputs provide separate relay contact closures for failure of the main and auxiliary inputs. You can also remotely select between auto and manual mode (with tally output), action the signal RESTORE, set the silence detection delay to be 2mins 5 seconds and define which input is the main input (with tally output). You can remotely start and

stop another piece of equipment on alarm failure and there is an option to set the remote start output as either momentary or latched.

The unit can be configured to alarm when either the left or right channel of the main input source fails, or if the whole stereo signal fails. Additionally, if one channel of a stereo signal is lost, you can define whether to mute the lost channel, or whether to mix the remaining channel to the lost side, effectively creating a mono signal. If the main source synchronisation is lost, you can define whether the unit switches to the auxiliary input immediately, or whether to treat the signal as silence to be detected and then switched based on the unit's silence detection settings.

Front panel LED indicators by the MAIN and AUX buttons show individually left and right programme and alarm conditions for both the main and auxiliary inputs.

A powerful feature of the RB-DSD1 is that by using the Sonifex SCi serial software, the unit can be programmed for different delay durations, levels and switching functions so that you can programme the unit for your specific application. A front panel DIPswitch configures the unit to be controlled serially

and a front panel LED indicates serial operation. Contact Sonifex for further information if you have a particular requirement that isn't catered for by the RB-DSD1 as standard.

The RB-DSD1 has been designed to have a passive signal path through the main input, so if power to the unit fails, signal input 1 is routed to output 1 and signal input 2 is routed to output 2. This is essential for applications such as installation at transmitter sites, where a power failure to the unit should not prevent the audio input signal from being output to the transmitter.



SCI Indicator Page.



SCI Miscellaneous Page.

## Specification For RB-DSD1

### Audio Specification

Dynamic Range:	>138dB
Distortion and Noise:	<-137dB THD + N at 1kHz, ref 0dB FS
Input & Output Impedances:	110Ω ±20% AES/EBU balanced I/O 75Ω ±5% S/PDIF unbalanced I/O 75Ω ±5% TOSlink unbalanced I/O 50Ω BNC TTL word clock input
Signal Level:	Balanced: 3V/10V peak to peak min/max Unbalanced: Min 0.5V±20% peak to peak
Sample Frequencies:	32, 44.1, 48, 88.2, 96, 176.4 or 192kHz
Bit Depth:	Up to and including 24 bit

### Front Panel Operational Controls & Indicators

Digital Input Select:	AES/EBU, S/PDIF or TOSlink optical via INPUT 1 or INPUT 2 push-buttons
Sync Input Select:	AES/EBU, wordclock, INPUT 1, INPUT 2 or video board, via front panel DIPswitch
Sync Mode Select:	Master, slave, auto or auto lock, via SYNC push-button
Alarm Threshold:	-39dBfs to -84dBfs in 3dBfs steps via front panel DIPswitches
Silence Detect Duration:	0 - 252 seconds in 2 second intervals via front panel DIPswitches
Detection Type:	Mono or stereo, via front panel DIPswitch
Restore Control:	Manual restore button & mode indication LED
Indicators:	Program and alarm indicators for left and right sources for both main and auxiliary inputs

### Rear Panel Operational Controls

Master Frequency Select:	32, 44.1, 48, 88.2, 96, 176.4 or 192kHz via rear panel DIPswitches
Input Select:	Main input from INPUT 1 or INPUT 2 via DIPswitch
Restore Mode:	Automatic or manual, via DIPswitch

Remote Start:	Latched or momentary, via DIPswitch
Channel Loss:	Mute channel or mix remaining, via DIPswitch
Sync Loss:	Switch immediately or treat as silence delay, via DIPswitch

### Connections

Digital Inputs:	2 x AES/EBU XLR 3 pin female 2 x S/PDIF RCA phono 2 x TOSlink optical input
Digital Outputs:	2 x AES/EBU XLR 3 pin plug 2 x S/PDIF RCA phono socket 2 x TOSlink optical output
Sync Inputs:	1 x AES/EBU XLR 3 pin female 1 x Word Clock BNC 1 x Video Input (optional)
Remote I/O Port:	15 way D-type plug
Serial Port:	RS232, 9 way D-Type
Mains Input:	Universal filtered IEC, continuously rated 85-264VAC @47- 63Hz, max 10W

Fuse Rating:	Anti-surge fuse 2A 20 x 5mm
--------------	-----------------------------

### Equipment Type

RB-DSD1:	Digital silence detection unit
----------	--------------------------------

### Physical Specifications

Dimensions (Raw):	48cm (W) x 10.8cm (D*) x 4.2cm (H) (1U) 19" (W) x 4.3" (D*) x 1.7" (H) (1U)
Dimensions (Boxed):	59cm (W) x 27.5cm (D*) x 11cm (H) 23.2" (W) x 10.8" (D*) x 4.3" (H)
Weight:	Nett: 1.4kg Gross: 2.0kg Nett: 3.1lb Gross: 4.4lb

### Accessories

RB-SYA:	Analogue video sync board (NTSC, PAL & SECAM)
RB-SYD:	Digital video sync board (SD-SDI & HD-SDI)
RB-RK3:	1U Rear panel rack kit for large Redboxes

\* Note that this product is deeper than standard Redboxes





## RB-DSD8 8 Channel Silence Switcher



**Category:** Synchronisers, Delays & Silence Detectors.

**Product Function:** A multi channel (4 stereo) silence detector which supports both analogue and digital signals and can switch between multiple 5.1 or 4 x stereo inputs on silence detection.

**Typical Applications:** At a radio transmitter site, as a quad stereo silence input detector and switcher. Two separate 5.1/7.1 mixer outputs can be connected and one switched to the other in the event of failure of the primary system.

**Features:** Analogue and digital I/O, very flexible configuration via front panel or Ethernet, channels can switch independently or can be linked to act together, adjustable silence detect threshold level and silence duration, passive signal path, switching of external equipment on silence detection, automatic or manual operation, mono or stereo operation, front panel LED indications of alarm status, dual redundant power supplies.

The RB-DSD8 8 channel silence switcher works in a similar way to the Sonifex RB-SD1 and RB-DSD1 but allows for 4 stereo channels of audio. These stereo audio channels can be either analogue or digital and can be used independently to give 4 stereo silence detectors or they can be linked to handle multichannel audio inputs, e.g. for 5.1 and 7.1 surround systems. Designed to switch from one input (or set of inputs) to another in the event of loss of audio, the unit is ideal at transmitter sites, or after the master output of a studio, to switch in another audio source, or simultaneous broadcast, should a master source fail.

The unit can switch:

- On loss of level of the main input.
- On loss of level on one channel of the main input.
- On loss of synchronisation lock of a main digital input.

The 2 x 8 channel audio inputs can accept both digital and analogue connections, with the unit automatically recognising a digital input. For the 8 channel outputs, by setting the appropriate DIPswitches, each stereo output can be designated as either an analogue pair or as a digital output, thus making the RB-DSD8 incredibly flexible and suitable for many different applications.

The unit level settings are in dBFS but when using analogue signals the equivalent full scale value can be set to +24dBu, +18dBu, or +12dBu by DIPswitches.

Each stereo pair has individual settings and controls and when stereo signals are linked, the foremost pair determines the switching characteristics and controls to be used. Each stereo pair has an AES LED that shows the status of the digital audio on that channel and a Selection LED to show that input is currently being sent to each respective output. Two Presence LEDs for the left and right inputs of each stereo pair indicate the input level of the channels.

The unit can switch between sources manually or automatically at the push of a button. If switching manually, silence detection is disabled and the user chooses when to switch using the main or backup buttons. If switching automatically, the unit switches between the two sources automatically upon the detection of silence. Each pair can be set to switch manually or automatically and the current setting is indicated by the Mode LED. Link/Select buttons are used to group channels together to access multichannel operation and switch simultaneously. Each pair has a Link/Select button which illuminates blue when active. Pressing and holding the first Link/Select

button with any other Link/Select button causes all inputs up to that point to be selected.

The RB-DSD8 has a 'slave mode' that allows you to connect two RB-DSD8 units and control them simultaneously from one unit.

The silence detect level is adjustable between -39dBFS and -84dBFS in 3dBFS steps via DIPswitches and this level is compared to peak signals. The silence interval can be adjusted between 2 seconds and 254 seconds in 2 second steps via DIPswitches.

A powerful feature of the RB-DSD8 is that by using the Sonifex SCI serial software, the unit can be programmed for different delay durations, levels and switching functions so that you can set up the unit for your specific application. A DIPswitch configures the unit to be controlled serially which is indicated by a front panel LED. You can control the unit remotely using either USB or Ethernet.

The RB-DSD8 has been designed with dual redundant power supplies. This means that if either power supply fails, the other is ready to take over. In the extremely unlikely event that both fail, the unit has been designed with a passive signal path through the main input. This is essential for applications such as installation at



transmitter sites, where a power failure to the unit should not prevent the audio input signal from being output to the transmitter.

Contact Sonifex for further information if you have a particular requirement that isn't catered for by the RB-DSD8 as standard.

### Clocking & Synchronisation

All digital input signals are routed to a sample rate converter allowing mixed incoming sample rates to be used. The output sample rates are selectable from a

predefined master clock of 32kHz, 44.1kHz, 48kHz, 88.2kHz, 96kHz, 176.4kHz or 192kHz or the clock can be derived from a sync input. When analogue inputs are selected, the analogue to digital converters are also clocked at that sample rate.

DIPSwitches choose the synchronisation mode and the sync source from TTL wordclock or AES/EBU through the dual-purpose synchronising input as standard. A front panel indicator shows

the status of the synchronisation input. Selectable sync modes are as follows:

**Master Mode** - In this mode the digital output sample rate is simply set by, and locked to, the internal on-board clock generator. No sync signal is used or required.

**Auto Lock Mode** - In this mode no output is generated until lock is achieved with a sync signal. The digital output sample rate now follows the sync input. If the sync signal is removed then the output sample rate is

set by, and locked to, the internal on-board clock generator at the closest frequency available to the previous sync input.

**Slave Mode** - Here the digital output sample rate follows the sync input. When the sync signal is not present the digital output is turned off.



Channel Specific Settings Webpage.

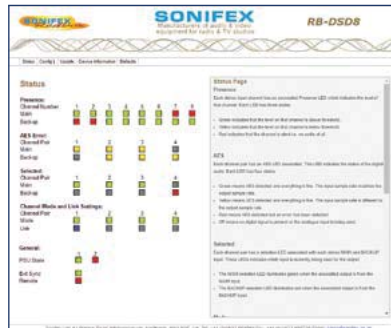

Status Webpage.

### Specification For RB-DSD8

#### Audio Specification - Digital

Dynamic Range:	>138dB
Distortion & Noise:	<-137dB THD + N at 1kHz, ref 0dBFS
Input & Output Impedances:	110Ω ± 20% AES/EBU balanced I/O 50Ω BNC TTL word clock input
Signal Level:	Balanced: 3V/10V peak to peak min/max
Sample Rates:	32, 44.1, 48, 88.2, 96, 176.4 or 192kHz
Bit Depth:	Up to and including 24 bit

#### Audio Specification - Analogue

Maximum Input Level:	+24dBu
Input Impedance:	>20kΩ bridging balanced
Dynamic Range:	>110dB
Distortion & Noise:	>82dB THD + N at 1kHz
Common Mode Rejection:	>60dB , ref 0dBu

#### Front Panel Operational Controls

Switch Mode Select:	Via AUTO, MANUAL or SLAVE push-buttons
Manual Source Select:	Via MAIN and BACKUP push-buttons
Group Selection :	Via LINK/SELECT push-buttons

#### Front Panel Indicators

Presence LEDs:	For all input channels
Link LEDs:	Show which channels are controlled concurrently
Mode LEDs:	Indicate the current mode selected for each group
Selection LEDs:	Indicate whether MAIN or BACKUP is selected
AES LEDs:	Show the state of the digital input to each group
PSU LEDs:	Show the state of each power supply
Remote Control LED:	Show if remote control is selected
External Sync LED:	Show the state of any sync inputs used.

#### Rear Panel - Operational Controls

Silence Threshold:	-39dBfs to -84dBfs in 3dBfs steps, via rear panel DIPswitches
Silence Duration:	0 - 254 seconds in 2 second intervals duration, via rear panel DIPswitches
Stereo/Mono Switching:	Stereo or mono, via rear panel DIPswitch
Master Select:	32, 44.1, 48, 88.2, 96, 176.4 or 192kHz Output sample rate, via rear panel DIPswitches

Ignore Silence:	Each channel can be set to ignore silences, via rear panel DIPswitches
Remote Control Enable:	Enabled or disabled, via rear panel DIPswitch
Sync Mode & Source Select:	Sync in master mode or sync from MAIN input1, AES or wordclock sync input in auto or slave mode, via rear panel DIPswitches

Remote Start:	Latched or momentary, via DIPswitch
Input Lock Loss:	Switch immediately or treat as silence delay, via rear panel DIPswitch

Digital or Analogue Output:	Digital or analogue, via rear panel DIPswitches
Full Scale Line Up:	24, 18 or 12 dBu = 0dBFS, via rear panel DIPswitches

Boot Mode:	Boot in boot or normal via rear panel DIPswitch
------------	---

#### Connections

Digital/Analogue Inputs:	2 x 8 channel inputs on 2 x 25 pin D-type male
Digital/Analogue Outputs:	1 x 8 channel outputs on 1 x 25 pin D-type female
Sync Inputs:	1 x BNC (Wordclock or AES)
Remote I/O Port:	25 way D-type female
SCi port:	USB or ethernet
Main Input:	2 x Universal filtered IEC, continuously rated 85-264VAC @47- 63Hz, max 60W
Fuse Rating:	2 x Anti-surge fuse 2A 20 x 5mm

#### Equipment Type

RB-DSD8:	8 channel silence switcher
----------	----------------------------

#### Physical Specifications

Dimensions (Raw):	48cm(W) x 22cm(D) x 4.2cm(H) 1U
Dimensions (Boxed):	19" (W) x 8.7" (D) x 1.7" (H) 1U
Weight:	55cm(W) x 28cm(D) x 17cm(H) 21.7" (W) x 11" (D) x 6.7" (H)
	Nett: 2.3kg Gross: 3.8kg
	Nett: 5.1lb Gross: 8.4lb

\* Note that this product is deeper than standard Redboxes

#### Accessories

RB-RK3:	1U Rear panel rack kit for large Redboxes
---------	---



## RB-FS42 Audio Failover Switcher, 4 Main I/O, 2 Standby I/O



**Category:** Synchronisers, Delays & Silence Detectors.

**Product Function:** To route the source audio signals in to a standby encoder in event of encoder fail. Or to route the destination audio signals from a standby decoder in event of decoder fail.

**Typical Applications:** As a failover switcher for multi channel audio transport over E1 or IP, typically as performed by APT Oslo, Prody's Nureus, where a N+1 topology is adopted.

**Features:**

- Relay based switching.
- Dual DC, or AC, power supplies (select when ordering).
- Encoder site (Set via IP): 4 stereo

program inputs, 4 + 2 stereo program outputs where each program input/ Output carries: analogue L/R, stereo AES/EBU & RS232.

- Encoder site: Each program output has an alarm detect GP input.
- Decoder Site (Set via IP): 4 +2 stereo program inputs, 4 program outputs where each program input carries: analogue L/R, stereo AES/EBU & RS232.
- Decoder Site: Each program input has an alarm detect GP input.
- AES/EBU transparent (for Dolby E transport).
- Passive throughput in event of power outage.
- GPO output for signalling RB-FS42 alarm conditions: PSU 1/2 fail, Standby 1/2 active, Summary Alarm.
- Automatic or Manual reversion modes.
- LED indicators on front panel.
- IP control, including Web GUI and SNMP.

The RB-FS42 4 + 2 audio failover switcher is a smaller channel count version of the RB-FS82, offering a lower number of inputs and outputs. It is a more cost effective solution where failover is needed for a smaller number of sources/destinations and supports all of the features of the RB-FS82.

The device has 4 main + 2 standby, stereo analogue audio, AES/EBU digital audio and RS232 connections (both inputs and outputs) and can be configured via Ethernet for two main operational applications:

1. For switching of program sources to a standby destination in the event of a destination failure ('Standbys to outputs'). Typically this would be audio encoders at a program distribution head end (for audio over IP, E1 or other bearer networks), with "N" x programs feeding "N" x encoders. If an encoder fails the audio destined for that encoder gets routed to a standby encoder so ensuring the continuity of audio to network transport.
2. Switching of program sources, including standby sources, to destinations in the event of source failure ('Standbys to inputs'). Typically this would be audio decoders at a transmission site with "N" x programs and "N" x decoders feeding "N" x transmitters. If a decoder fails, the audio from a standby decoder, or other audio source such as an mp3 player, overrides the signal path to the transmitter so ensuring continuity on air.

The RB-FS42 supports any configuration of up to 4 main program signal paths ( $N \leq 4$ ) and there are 2 standby program signal paths, in either mode of operation. Each program path simultaneously switches analogue L/R audio, AES/EBU digital audio and RS232 data. Each of these signals is wired on D-Type connectors on the rear panel.

All signal paths are passive and therefore completely transparent utilising relay based switching. This has the benefit of a "straight wire" topology during normal (alarm free) operation and also during any power outage to the device. An additional benefit of the passive signal path is AES/EBU bit transparency allowing throughput of AES/EBU AC3 Dolby E TM signals.

To ensure the passive nature of the device, switching is determined by alarm (General Purpose) inputs, with this alarm signalling in turn being normally provided by the encoder or decoders (or other devices) at site. Recognising the mission critical nature of the system, a high grade of relay is used in the RB-FS42.

The passive design ensures continuity of audio in the event of any power outage. However the RB-FS42 also includes dual redundant power supplies (85V-264V AC with a 12V 1A DC backup as standard). The RB-FS42-DC model accepts two DC power inputs (24 - 48V DC) via locking 2.5mm pin power connectors and both power supplies are monitored by the unit. This means that if either power supply fails, the other is ready to take over. In the extremely unlikely event that both fail, the unit's passive signal path ensures a straight wire connection for all 4 program feeds (analogue, AES/EBU &



RS232). This is essential for applications such as installation at transmitter sites, where a power failure to the unit will not prevent the audio input signal from being output to each of the supported 4 transmitters.

Please see the RB-FS82 description (Page 84) for more information on LED indicators, GPIO functions, Main and Standby routing, alarm clearing and SNMP management features - the RB-FS42 is identical in this respect.

Contact Sonifex for further information if you have a particular requirement that isn't catered for by the RB-FS42 as standard.

### Specification For RB-FS42

#### Audio Specification - Digital

The RB-FS42 uses passive fixed switching relays which don't affect the overall audio performance

#### Audio Specification - Analogue

Crosstalk: >86dB

#### Front Panel Operational Controls

Manual Switching: Via Restore 1 & Restore 2 push-buttons

#### Front Panel Indicators

Power LEDs: 2 x Power indicators  
 Channel Status LEDs: 8 x Standby status indicators, 2 per channel  
 Standby Restore LEDs: 2 x illuminated buttons

#### Rear Panel Connections

Analogue Inputs: 4 x differential stereo inputs across 1 x 25 way D-type female  
 Digital Inputs: 4 x inputs on 1 x 25 way D-type female

Analogue Outputs: 4 x outputs on 1 x 25 way D-type female  
 Digital Outputs: 4 x outputs on 1 x 25 way D-type female  
 RS232 Inputs: 4 x RS232 communication lines on 1 x 25 way D-type female  
 RS232 Outputs: 4 x RS232 communication lines on 1 x 25 way D-type female  
 GPIO: 6 Inputs & 5 outputs on 1 x 25 pin D-type female  
 Standby & 2 Inputs: 2 x Analogue differential stereo inputs  
 2 x Stereo digital inputs  
 2 x RS232 communication line pairs on 1 x 25 way D-type female  
 Ethernet Port: 10/100Mbps on 1 x RJ45 socket for IP control, SNMP and web GUI  
 Mains Input (AC): 1 x Universal filtered IEC, continuously rated 85-264VAC @47-63Hz, max 20W, plus 1 x 12V 1A DC supply, 2.5mm locking socket fused.  
 or (Dual DC): 2 x 18V-50V 20W max, DC supply, 2.5mm locking socket fused.

Fuse Rating (AC): 1 x Anti-surge fuse 2A 20 x 5mm  
**Equipment Type**  
 RB-FS42: Audio failover switcher, 4 + 2 inputs  
 RB-FS42DC: Audio failover switcher, 4 + 2 inputs, 2 x DC inputs  
**Physical Specifications**  
 Dimensions (Raw): 48cm(W) x 22cm(D) x 4.2cm(H) 1U  
 19" (W) x 8.7" (D) x 1.7" (H) 1U  
 Dimensions (Boxed): 55cm(W) x 28cm(D) x 17cm(H)  
 21.7" (W) x 11" (D) x 6.7"  
 Weight: Nett: 2.1kg Gross: 3.5kg  
 Nett: 4.6lb Gross: 7.7lb  
 \* Note that this product is deeper than standard Redboxes  
**Accessories**  
 RB-RK3: 1U Rear panel rack kit for large Redboxes





## RB-FS82 Audio Failover Switcher, 8 Main I/O, 2 Standby I/O



**Category:** Synchronisers, Delays & Silence Detectors.

**Product Function:** To route the source audio signals in to a standby encoder in event of encoder fail. Or to route the destination audio signals from a standby decoder in event of decoder fail.

**Typical Applications:** As a failover switcher for multi channel audio transport over E1 or IP, typically as performed by APT Oslo, Prody's Nureus, where a N+1 topology is adopted.

**Features:**

- Relay based switching.
- Dual DC, or AC, power supplies (select when ordering).
- Encoder site (Set via IP): 8 stereo

program inputs, 8 + 2 stereo program outputs where each program input/ Output carries: analogue L/R, stereo AES/EBU & RS232.

- Encoder site: Each program output has an alarm detect GP input.
- Decoder Site (Set via IP): 8 + 2 stereo program inputs, 8 program outputs where each program input carries: analogue L/R, stereo AES/EBU & RS232.
- Decoder Site: Each program input has an alarm detect GP input.
- AES/EBU transparent (for Dolby E transport).
- Passive throughput in event of power outage.
- GPO output for signalling RB-FS82 alarm conditions: PSU 1/2 fail, Standby 1/2 active, Summary Alarm.
- Automatic or Manual reversion modes.
- LED indicators on front panel.
- IP control, including Web GUI and SNMP.

The RB-FS82 8 + 2 audio failover switcher is an important tool in many critical areas in telecommunications and broadcast chains. The device has 8 main + 2 standby, stereo analogue audio, AES/EBU digital audio and RS232 connections (both inputs and outputs) and can be configured via Ethernet for two main operational applications:

1. For switching of program sources to a standby destination in the event of a destination failure ('Standbys to outputs'). Typically this would be audio encoders at a program distribution head end (for audio over IP, E1 or other bearer networks), with "N" x programs feeding "N" x encoders. If an encoder fails the

audio destined for that encoder gets routed to a standby encoder so ensuring the continuity of audio to network transport.

2. Switching of program sources, including standby sources, to destinations in the event of source failure ('Standbys to inputs'). Typically this would be audio decoders at a transmission site with "N" x programs and "N" x decoders feeding "N" x transmitters. If a decoder fails, the audio from a standby decoder, or other audio source such as an mp3 player, overrides the signal path to the transmitter so ensuring continuity on air.

The RB-FS82 supports any configuration of up to 8 main program signal paths ( $N \leq 8$ ) and there are 2 standby program signal paths, in either modes of operation. Each program path simultaneously switches analogue L/R audio, AES/EBU digital audio and RS232 data. Each of these signals is wired on D-type connectors on the rear panel.

All signal paths are passive and therefore completely transparent utilising relay based switching. This has the benefit of a "straight wire" topology during normal (alarm free) operation and also during any power outage to the device. An additional benefit

of the passive signal path is AES/EBU bit transparency allowing throughput of AES/EBU AC3 Dolby E (TM) signals.

To ensure the passive nature of the device, switching is determined by alarm (General Purpose) inputs, with this alarm signalling in turn being normally provided by the encoder or decoders (or other devices) at site. Recognising the mission critical nature of the system, a high grade of relay is used in the RB-FS82.

The passive design ensures continuity of audio in the event of any power outage. However the RB-FS82 also includes dual redundant power supplies (AC with a DC backup as standard, or dual DC by ordering RB-FS82DC). This means that if either power supply fails, the other is ready to take over. In the extremely unlikely event that both fail, the unit's passive signal path ensures a straight wire connection for all 8 program feeds (analogue, AES/EBU & RS232). This is essential for applications such as installation at transmitter sites, where a power failure to the unit will not prevent the audio input signal from being output to each of the supported 8 transmitters.

A row of LEDs on the front panel confirm the unit status, with each individual program path indicated as being in alarm with



either Standby 1 or Standby 2 programs clearly confirmed as actively over-riding the failed signal. Alarm LEDs on the front panel are also indicated for power supply 1 failure and power supply 2 failure and these are also mirrored by the device's own General Purpose Outputs so facilitating easy interfacing of the device with the addition of a summary alarm status GPO. In the event of alarm clearing, the unit will automatically revert to normal operation, but a manual reversion mode is also provided, allowing for engineering investigation without the unit 'hunting' between different signal paths. Two buttons on the front panel, RESTORE 1 and RESTORE 2, allow manual restoration of the previously failed signal paths, away from Standby 1 and Standby 2 respectively

and these can be remotely controlled over Ethernet.

To facilitate integration with site management systems the RB-FS82 supports SNMP control and is configured by a simple web based GUI.

Contact Sonifex for further information if you have a particular requirement that isn't catered for by the RB-FS82 as standard.

### Specification For RB-FS82

#### Audio Specification - Digital

The RB-FS82 uses passive fixed switching relays which don't affect the overall audio performance

#### Audio Specification - Analogue

Crosstalk: >86dB

#### Front Panel Operational Controls

Manual Switching: Via Restore 1 & Restore 2 push-buttons

#### Front Panel Indicators

Power LEDs:	2 x Power indicators
Channel Status LEDs:	16 x Standby status indicators, 2 per channel
Standby Restore LEDs:	2 x illuminated buttons

#### Rear Panel Connections

Analogue Inputs:	8 x differential stereo inputs across 2 x 25 way D-types female
Digital Inputs:	8 x inputs on 1 x 25 way D-type female
Analogue Outputs:	8 x inputs on 1 x 25 way D-type female
Digital Outputs:	8 x outputs on 1 x 25 way D-type female
RS232 Inputs:	8 x RS232 communication lines on 1 x 25 way D-type female
RS232 Outputs:	8 x RS232 communication lines on 1 x 25 way D-type female
GPI/O:	10 Inputs & 5 outputs on 1 x 25 pin D-Type female
Standby 1&2 Inputs:	2 x Analogue differential stereo inputs 2 x Stereo digital inputs 2 x RS232 communication line pairs on 1 x 25 way D-type female

Ethernet Port:	10/100Mbps on 1 x RJ45 socket for IP control, SNMP and web GUI
Mains Input (AC):	1 x Universal filtered IEC, continuously rated 85-264VAC @47- 63Hz, max 20W, plus 1 x 12V 1A DC supply, 2.5mm locking socket fused.
or (Dual DC):	2 x 18V-50V 20W max, DC supply, 2.5mm locking socket fused.
Fuse Rating (AC):	1 x Anti-surge fuse 2A 20 x 5mm

#### Equipment Type

RB-FS82:	Audio failover switcher, 8 + 2 inputs
RB-FS82DC:	Audio failover switcher, 8 + 2 inputs, 2 x DC inputs

#### Physical Specifications

Dimensions (Raw):	48cm(W) x 22cm(D) x 4.2cm(H) 1U
Dimensions (Boxed):	55cm(W) x 28cm(D) x 17cm(H) 21.7" (W) x 11" (D) x 6.7"
Weight:	Nett: 2.2kg Gross: 3.6kg Nett: 4.8lb Gross: 8.0lb

\* Note that this product is deeper than standard Redboxes

#### Accessories

RB-RK3:	1U Rear panel rack kit for large Redboxes
---------	---



## RB-UL1 Single Stereo Unbalanced To Balanced Converter



**Category:** Matching Converters.

**Product Function:** Converting unbalanced audio signals to balanced audio signals.

**Typical Applications:** Interfacing domestic unbalanced audio devices e.g. a CD player or ipod to balanced audio equipment.

**Features:** Pre-set left and right gain controls, Neutrik XLR output connectors.

The RB-UL1 is a single stereo unit for interfacing domestic or semi-professional unbalanced equipment, such as a CD player, to professional balanced line levels.

The two RCA unbalanced inputs have an impedance of 10kΩ and are routed to two balanced XLR-3 outputs with an output impedance of <math><50\Omega</math>.

The output gain can be individually adjusted for left and right channels by using pre-set potentiometers accessible through the rear panel.

### Specification For RB-UL1

#### Audio Specification

Maximum Input Level:	+28dBu
Input Impedance:	>10kΩ
Maximum Output Level:	+28dBu
Output Impedance:	<math><50\Omega</math>
Distortion:	0.01% THD @ 1kHz, ref +8dBu output
Noise:	-100dB, unity gain, ref +8dBu output
Frequency Response:	20Hz to 20kHz $\pm 0.1$ dB (600Ω load, ref 1kHz)
Gain Range:	Balanced output : -15dBu to +15dBu, ref -15dBu into unbalanced RCA input

#### Connections

Inputs:	2 x RCA phono (Unbalanced)
Outputs:	2 x XLR 3 pin male (Balanced)

Mains Input:	Filtered IEC, switchable 110-120V, or 220-240V, fused, 6W max
Fuse Rating:	Anti-surge fuse 100mA 20 x 5mm (230VAC) Anti-surge fuse 250mA 20 x 5mm (115VAC)

#### Equipment Type

RB-UL1:	Single stereo unbalanced to balanced converter
---------	--

#### Physical Specification

Dimensions (Raw):	28cm (W) x 10.8cm (D) x 4.2cm (H) (1U) 11" (W) x 4.3" (D) x 1.7" (H) (1U)
Dimensions (Boxed):	36cm (W) x 20.5cm (D) x 6cm (H) 14.2" (W) x 8" (D) x 2.4" (H)
Weight:	Nett: 1.00kg Gross: 1.45kg Nett: 2.2lbs Gross: 3.2lbs



## RB-UL2 Dual Stereo Unbalanced To Balanced Converter



**Category:** Matching Converters.

**Product Function:** Converting unbalanced audio signals to balanced audio signals for two stereo channels.

**Typical Applications:** Interfacing domestic unbalanced audio devices e.g. a CD player or ipod to balanced audio equipment.

**Features:** Pre-set left and right gain controls, Neutrik XLR output connectors.

The RB-UL2 is a dual stereo unit for interfacing domestic or semi-professional unbalanced equipment to professional balanced line levels.

All connections are on the rear panel. Four RCA unbalanced inputs have an impedance of 10kΩ and are routed to four balanced XLR-3 outputs with an output impedance of <50Ω.

The output gain can be individually adjusted for left and right channels by using pre-set potentiometers accessible through the rear panel, allowing you to feed both balanced and unbalanced equipment.

### Specification For RB-UL2

#### Audio Specification

Maximum Input Level:	+28dBu
Input Impedance:	>10kΩ
Output Impedance:	<50Ω
Maximum Output Level:	+28dBu
Distortion:	0.01% THD @ 1kHz, ref +8dBu output
Noise:	-100dB, unity gain, ref +8dBu output
Frequency Response:	20Hz to 20kHz ±0.1dB (600Ω load, ref 1kHz)
Gain Range:	Balanced output : -15dBu to +15dBu, ref -15dBu into unbalanced RCA input

#### Connections

Inputs:	4 x RCA phono (Unbalanced)
Outputs:	4 x XLR 3 pin male (Balanced)
Mains Input:	Filtered IEC, switchable 110-120V, or 220-240V, fused, 6W max
Fuse Rating:	Anti-surge fuse 100mA 20 x 5mm (230VAC) Anti-surge fuse 250mA 20 x 5mm (115VAC)

#### Equipment Type

RB-UL2:	Dual stereo unbalanced to balanced converter
---------	--

#### Physical Specification

Dimensions (Raw):	28cm (W) x 10.8cm (D) x 4.2cm (H) (1U) 11" (W) x 4.3" (D) x 1.7" (H) (1U)
Dimensions (Boxed):	36cm (W) x 20.5cm (D) x 6cm (H) 14.2" (W) x 8" (D) x 2.4" (H)
Weight:	Nett: 1.05kg Gross: 1.5kg Nett: 2.3lbs Gross: 3.3lbs



## RB-UL4 Quad Stereo Unbalanced To Balanced Converter



**Category:** Matching Converters.

**Product Function:** Converting unbalanced audio signals to balanced audio signals for four stereo channels.

**Typical Applications:** Interfacing domestic unbalanced audio devices e.g. a CD player or ipod to balanced audio equipment.

**Features:** Pre-set left and right gain controls, Neutrik XLR output connectors.

The RB-UL4 is a 1U rack-mount quad stereo unit for interfacing domestic or semi-professional unbalanced equipment to professional balanced line levels.

All connections are on the rear panel. The eight RCA unbalanced inputs have an impedance of 10kΩ and are routed to eight balanced XLR-3 outputs with an output impedance of <math><50\Omega</math>.

The output gain can be individually adjusted for left and right channels by using pre-set potentiometers accessible through the rear panel.

### Specification For RB-UL4

Audio Specification For RB-UL4	
Maximum Input Level:	+28dBu
Maximum Output Level:	+28dBu
Input Impedance:	>10kΩ
Output Impedance:	<math><50\Omega</math>
Distortion:	0.01% THD @ 1kHz, ref +8dBu output
Noise:	-100dB, unity gain, ref +8dBu output
Frequency Response:	20Hz to 20kHz $\pm 0.1$ dB (600Ω load, ref 1kHz)
Gain Range:	Balanced output : -15dBu to +15dBu, ref -15dBu into unbalanced RCA input

### Connections

Inputs:	8 x RCA phono (Unbalanced)
Outputs:	8 x XLR 3 pin male (Balanced)
Mains Input:	Filtered IEC, switchable 110-120V, or 220-240V, fused, 6W max
Fuse Rating:	Anti-surge fuse 100mA 20 x 5mm (230VAC) Anti-surge fuse 250mA 20 x 5mm (115VAC)

### Equipment Type

RB-UL4:	Quad stereo unbalanced to balanced converter
---------	--

### Physical Specification

Dimensions (Raw):	48cm (W) x 10.8cm (D) x 4.2cm (H) (1U) 19" (W) x 4.3" (D) x 1.7" (H) (1U)
Dimensions (Boxed):	58.5cm (W) x 22.5cm (D) x 7cm (H) 23" (W) x 8.9" (D) x 2.8" (H)
Weight:	Nett: 1.3kg Gross: 1.9kg Nett: 2.9lbs Gross: 4.2lbs







## RB-LU4 Quad Stereo Balanced To Unbalanced Converter

The RB-LU4 is a 1U rack-mount quad stereo unit for interfacing professional balanced line levels to domestic or semi-pro unbalanced equipment, e.g. for connecting a pro satellite receiver to a consumer hi-fi system.

All connections are on the rear panel. The eight balanced XLR-3 inputs have an impedance of 20k $\Omega$  and are routed to eight unbalanced RCA outputs with an output impedance of <50 $\Omega$ .

The output gain can be individually adjusted for left and right channels by using pre-set potentiometers accessible through the rear panel.

A LED power indicator on the front panel displays the power supply connection.

### Specification For RB-LU4

#### Audio Specification

Maximum Input Level:	+28dBu
Input Impedance (XLR):	>20k $\Omega$ balanced bridging
Output Impedance (RCA):	<50 $\Omega$
Maximum Output Level:	+22dBu
Distortion:	0.01% THD @ 1kHz, ref +8dBu output
Noise:	-100dB, unity gain, ref +8dBu output
Common Mode Rejection:	>66dB typically
Frequency Response:	20Hz to 20kHz $\pm$ 0.1dB (600 $\Omega$ load, ref 1kHz)
Gain Range:	Unbalanced Output : -28dBu to 0dBu, ref 0dBu into balanced XLR input

#### Connections

Inputs:	8 x XLR 3 pin female (Balanced)
Outputs:	8 x RCA phono (Unbalanced)
Mains Input:	Filtered IEC, switchable 110-120V, or 220-240V, fused, 6W max
Fuse Rating:	Anti-surge fuse 100mA 20 x 5mm (230VAC) Anti-surge fuse 250mA 20 x 5mm (115VAC)

#### Equipment Type

RB-LU4:	Quad stereo balanced to unbalanced converter
---------	--

#### Physical Specification

Dimensions (Raw):	48cm (W) x 10.8cm (D) x 4.2cm (H) (1U) 19" (W) x 4.3" (D) x 1.7" (H) (1U)
Dimensions (Boxed):	58.5cm (W) x 22.5cm (D) x 7cm (H) 23" (W) x 8.9" (D) x 2.8" (H)
Weight:	Nett: 1.3kg Gross: 1.9kg Nett: 2.9lbs Gross: 4.2lbs

**Category:** Matching Converters.

**Product Function:** Converting balanced audio signals to unbalanced audio signals for four stereo channels.

**Typical Applications:** Interfacing a professional satellite receiver to an unbalanced hi-fi system.

**Features:** Pre-set left and right output gain controls, Neutrik XLR input connectors.





## RB-BL2 Single Stereo Bi-Directional Matching Converter



**Category:** Matching Converters.

**Product Function:** Converting unbalanced audio signals to balanced audio signals and vice-versa for one stereo channel.

**Typical Applications:** Providing bi-directional matching conversion between an unbalanced and balanced piece of equipment, typically between an unbalanced portable recorder & balanced USB or flashcard playback device.

**Features:** Pre-set left and right output gain controls, Neutrik XLR input and output connectors.



The RB-BL2 is a bi-directional stereo unit for interfacing domestic or semi-pro unbalanced equipment to professional balanced line levels, and vice-versa.

The two XLR-3 electronically balanced inputs have an impedance of 20kΩ bridging and are routed to two unbalanced RCA (phono) outputs with an output impedance of <50Ω.

The two RCA unbalanced inputs have an impedance of 20kΩ and are routed to two balanced XLR-3 outputs with an output impedance of <50Ω. All connections are on the rear panel.

The output gain can be adjusted for left and right channels by using pre-set potentiometers accessible through the rear panel.

### Specification For RB-BL2

#### Audio Specification

Maximum Input Level:	+28dBu
Maximum Output Level:	+28dBu
Input Impedance (RCA):	>10kΩ unbalanced
Input Impedance (XLR):	>20kΩ balanced bridging
Output Impedance (RCA):	<50Ω
Output Impedance (XLR):	<50Ω
Distortion:	0.01% THD @ 1kHz, ref +8dBu output
Noise:	-100dB, unity gain, ref +8dBu output
Common Mode Rejection:	>66dB typically
Frequency Response:	20Hz to 20kHz ±0.1dB (600Ω load, ref 1kHz)
Gain Range:	Unbalanced Output : -28dBu to 0dBu, ref 0dBu into balanced XLR input Balanced Output : -15dBu to +15dBu, ref -15dBu into unbalanced RCA input

#### Connections

Inputs:	2 x RCA phono (Unbal), 2 x XLR 3 pin female (Bal)
Outputs:	2 x XLR 3 pin male (Bal), 2 x RCA phono (Unbal)
Mains Input:	Filtered IEC, switchable 110-120V, or 220-240V, fused, 6W max
Fuse Rating:	Anti-surge fuse 100mA 20 x 5mm (230VAC) Anti-surge fuse 250mA 20 x 5mm (115VAC)

#### Equipment Type

RB-BL2:	Single stereo bi-directional matching converter
---------	---

#### Physical Specification

Dimensions (Raw):	28cm (W) x 10.8cm (D) x 4.2cm (H) (1U) 11" (W) x 4.3" (D) x 1.7" (H) (1U)
Dimensions (Boxed):	36cm (W) x 20.5cm (D) x 6cm (H) 14.2" (W) x 8" (D) x 2.4" (H)
Weight:	Nett: 1.0kg Gross: 1.4kg Nett: 2.2lbs Gross: 3.1lbs



## RB-BL4 Dual Stereo Bi-Directional Matching Converter

The RB-BL4 is a dual bi-directional stereo unit for interfacing domestic or semi-pro unbalanced equipment to professional balanced line levels, and vice versa.

The four XLR-3 electronically balanced inputs have an impedance of 20kΩ bridging and are routed to four unbalanced RCA (phono) outputs with an output impedance of <50Ω.

The four RCA unbalanced inputs have an impedance of 20kΩ and are routed to four balanced XLR-3 outputs with an output impedance of <50Ω. All connections are on the rear panel.

The output gain can be adjusted for left and right channels by using pre-set potentiometers accessible through the rear panel.

### Specification For RB-BL4

#### Audio Specification

Maximum Input Level:	+28dBu
Maximum Output Level:	+28dBu
Input Impedance (RCA):	>10kΩ unbalanced
Input Impedance (XLR):	>20kΩ balanced bridging
Output Impedance (RCA):	<50Ω
Output Impedance (XLR):	<50Ω
Distortion:	0.01% THD @ 1kHz, ref +8dBu output
Noise:	-100dB, unity gain, ref +8dBu output
Common Mode Rejection:	>66dB typically

Frequency Response:	20Hz to 20kHz ±0.1dB (600Ω load, ref 1kHz)
Gain Range:	Unbalanced Output : -28dBu to 0dBu, ref 0dBu into balanced XLR input Balanced Output : -15dBu to +15dBu, ref -15dBu into unbalanced RCA input

#### Connections

Inputs:	4 x RCA phono (Unbal), 4 x XLR 3 pin female (Bal)
Outputs:	4 x XLR 3 pin male (Bal), 4 x RCA phono (Unbal)
Mains Input:	Filtered IEC, switchable 110-120V, or 220-240V, fused, 6W max
Fuse Rating:	Anti-surge fuse 100mA 20 x 5mm (230VAC) Anti-surge fuse 250mA 20 x 5mm (115VAC)

#### Equipment Type

RB-BL4:	Dual stereo bi-directional matching converter
---------	---

#### Physical Specification

Dimensions (Raw):	48cm (W) x 10.8cm (D) x 4.2cm (H) (1U) 19" (W) x 4.3" (D) x 1.7" (H) (1U)
Dimensions (Boxed):	58.5cm (W) x 22.5cm (D) x 7cm (H) 23" (W) x 8.9" (D) x 2.8" (H)
Weight:	Nett: 1.3kg Gross: 1.9kg Nett: 2.9lbs Gross: 4.2lbs



**Category:** Matching Converters.

**Product Function:** Converting unbalanced audio signals to balanced audio signals and vice-versa for two stereo channels.

**Typical Applications:** Providing bi-directional matching conversion between an unbalanced and balanced piece of equipment, typically between an unbalanced portable recorder & balanced USB or flashcard playback device.

**Features:** Pre-set left and right output gain controls, Neutrik XLR input and output connectors.





## RB-PA2 Dual Stereo RIAA Phono Amplifier



**Category:** Matching Converters.  
**Description:** Dual Stereo RIAA Phono Amplifier.  
**Product Function:** A record player/turntable pre-amp providing RIAA equalisation.  
**Typical Applications:** Specifically for use with record decks/DJ turntables e.g. for vinyl transfers.  
**Features:** Superbly transparent signal, powerful bass response, Neutrik XLR connectors, adjustable output gain.

The RB-PA2 is a dual stereo RIAA equalised phono amplifier. This record player preamp amplifies the small signal from your pick up cartridge (either moving magnet or high output moving coil magnetic) and provides the necessary RIAA equalisation required for vinyl records, to match it to a line input of your mixer, or amplifier. It uses a clean RIAA response making it ideal for use with broadcast turntables and DJ decks and where vinyl records are being archived to CD for high quality transfers, or for converting albums to mp3.



It operates with phono cartridges with a nominal output of 1mV to 25mV and has been specifically tested to work with the Technics SL-1200™ and 1210™ range of turntables. Quality high specification components have been used together with low noise, fast acting operational amplifiers to produce a superbly transparent signal path. Additionally, the RB-PA2 runs without a rumble filter to produce a powerful bass response.

The RB-PA2 is a dual stereo unit to interface up to two turntables. The inputs are phono connectors with Neutrik XLR connectors for the balanced outputs, which may be wired unbalanced if required. Output gain is individually adjustable for left and right channels in the range 35dB to 65dB by using

pre-set potentiometers. Frequency response is held within 0.5dB of the RIAA curve and noise is typically better than -84dB RMS A weighted at 40dB gain.

### Specification For RB-PA2

Audio Specification	
Input Impedance:	>47kΩ
Input Sensitivity Range:	1mV to 31mV (ref 1kHz)
Maximum Output Level:	+28dBu
Output impedance:	<50Ω
Output Gain Range:	Adjustable 28dB to 60dB gain via 4 multi-turn pots
Crosstalk:	Better than -80dBu at 1kHz
Frequency Response:	10Hz-15kHz (-3dB)
RIAA Accuracy:	Within 0.5dB of RIAA curve
Distortion:	0.01% THD @ 1kHz, ref +8dBu output
Noise:	-77dB (CCIR Q-Pk, 20Hz-20kHz)

Headroom:	27dB for 3mV input
Dynamic Range:	90dB
Connections	
Analogue Inputs:	4 x RCA Phono sockets.
Analogue Outputs:	4 x XLR 3 pin male (balanced) (L & R)
Earth Tag:	Grounding turret tag
Mains Input:	Filtered IEC, switchable 110-120V, or 220-240V, fused, 6W max.
Fuse Rating:	Anti-surge fuse 100mA 20 x 5mm (230VAC) Anti-surge fuse 250mA 20 x 5mm (115VAC)
Equipment Type	
RB-PA2:	Dual stereo RIAA phono amplifier
Physical Specification	
Dimensions (Raw):	28cm (W) x 10.8cm (D) x 4.2cm (H) (1U) 11" (W) x 4.3" (D) x 1.7" (H) (1U)
Dimensions (Boxed):	36cm (W) x 20.5cm (D) x 6cm (H) 14.2" (W) x 8" (D) x 2.4" (H)
Weight:	Nett: 1.1kg Gross: 1.5kg Nett: 2.4lbs Gross: 3.3lbs





## RB-LI2 Stereo Line Isolation Unit



**Category:** Matching Converters.

**Product Function:** Used to isolate audio signals from inter-area ground hum loops.

**Typical Applications:** To reduce earth hum problems, especially when the equipment at each end of your cable run is powered for either different mains power supplies or different phases of the same supply. To create an isolated distribution point, or if you need to take a feed from somewhere that doesn't have a distribution amplifier.

**Features:** Transformer isolation, loop-through output, output gain control.

The RB-LI2 stereo line isolation unit is used to isolate audio signals from inter-area ground hum loops, which could be caused by equipment being powered by different mains power supplies, or different phases on the same supply.

The input and output are connected together through a transformer, which has internal jumpers allowing the outputs to be balanced about ground.

There is also a loop-through output, so that the RB-LI2 can be inserted into a line, forming a transformer balanced distribution point.

The isolated outputs can be individually adjusted using pre-set potentiometers,

accessible through the rear panel. The gain range of the stereo line isolation unit is -15dB to +13.5dB (28.5dB).

This unit is useful where audio is required to be driven over a relatively long length of cable. By isolating the signal using transformers, ground loop currents that can be present in non-isolated signals, are eradicated completely.

### Specification For RB-LI2

#### Audio Specification

Output impedance:	<150Ω
Distortion:	0.5% THD @ 40Hz, ref +17dBu output
Common Mode Rejection:	<64dB typically
Frequency Response:	10Hz to 36kHz ±0.5dB

Output Gain Range: -15dB to +13.5dB

#### Connections

Inputs:	2 x XLR 3 pin female (Balanced)
Isolated Outputs:	2 x XLR 3 pin male (Balanced)
Loop Outputs:	2 x XLR 3 pin male (Balanced)
Mains Input:	Filtered IEC, switchable 110-120V, or 220-240V, fused, 6W max
Fuse Rating:	Anti-surge fuse 100mA 20 x 5mm (230VAC) Anti-surge fuse 250mA 20 x 5mm (115VAC)

#### Equipment Type

RB-LI2: Stereo line isolation unit

#### Physical Specification

Dimensions (Raw):	28cm (W) x 10.8cm (D) x 4.2cm (H) (1U) 11" (W) x 4.3" (D) x 1.7" (H) (1U)
Dimensions (Boxed):	36cm (W) x 20.5cm (D) x 6cm (H) 14.2" (W) x 8" (D) x 2.4" (H)
Weight:	Nett: 1.1kg Gross: 1.5kg Nett: 2.4lbs Gross: 3.3lbs







## RB-PLI6 6 Way Mono Passive Line Isolation Unit



**Category:** Matching Converters.

**Product Function:** Used to isolate audio signals from inter-area ground hum loops for 6 mono or 3 stereo channels

**Typical Applications:** To reduce earth hum problems, especially when the equipment at each end of your cable run is powered for either different mains power supplies or different phases of the same supply. OB trucks where multiple isolated audio feeds are required to different locations on the broadcast.

**Features:** Passive unit so no power is required and it eliminates ground hum.

The RB-PLI6 passive line isolation unit is used to isolate audio signals from inter-area ground hum loops, which could be caused by equipment being powered by different mains power supplies or phases on the same supply.

The input and output are connected together through a transformer, and the unit has internal jumpers allowing the inputs and/or outputs to be balanced about ground. The unit requires no mains power for operation.

This unit is useful where audio is required to be driven over a relatively long length of cable. By isolating the signal using transformers, ground loop currents which can be present in non-isolated signals, are eradicated completely.

### Specification For RB-PLI6

#### Audio Specification

Output impedance:	<150Ω
Distortion:	0.5% THD @ 40Hz, ref +17dBu output
Common Mode Rejection:	>64dB typically
Frequency Response:	10Hz to 36kHz ±0.5dB

#### Connections

Inputs:	6 x XLR 3 pin female (Balanced)
Outputs:	6 x XLR 3 pin male (Balanced)

#### Equipment Type

RB-PLI6:	6 way mono passive line isolation unit
----------	--

#### Physical Specification

Dimensions (Raw):	48cm (W) x 10.8cm (D) x 4.2cm (H) (1U) 19" (W) x 4.3" (D) x 1.7" (H) (1U)
Dimensions (Boxed):	58.5cm (W) x 22.5cm (D) x 7cm (H) 23" (W) x 8.9" (D) x 2.8" (H)
Weight:	Nett: 1.5kg Gross: 1.9kg Nett: 3.3lbs Gross: 4.2lbs





## RB-DA6 6 Way Stereo Distribution Amplifier

The RB-DA6 is a 1U rack-mount high performance 6 way stereo distribution amplifier for splitting a source into a number of different outputs.

The RB-DA6 has 1 stereo input and 6 stereo outputs. It can also be configured so that 1 mono input can be distributed to 12 outputs by use of a switch which is recessed on the front panel to prevent it being accidentally knocked.

The XLR-3 inputs and outputs are electronically balanced and can be wired unbalanced. Each output is individually buffered so that a short circuit on one output won't affect the others.

The left and right input gain controls (normalising) are pre-set potentiometers accessible through the front panel.

The output gain may be varied from -8dB to 18dB which is useful for normalising consumer and professional signals to give outputs of -15dBu and 0dBu respectively.



**Category:** Audio Distribution Amplifiers.  
**Product Function:** Audio distribution to multiple destinations.

**Typical Applications:** Distribute line level signals to multiple reporters in a broadcast centre, distribute main programme output from a mixer to other studios.

**Features:** Input level adjustment, mono/stereo switch, Neutrik XLR audio connectors.

### Specification For RB-DA6

Audio Specification	
Maximum Input Level:	+28dBu
Maximum Output Level:	+28dBu
Frequency Response:	20Hz to 20kHz ±0.1dB (600Ω load, ref 1kHz)
Gain Range:	Adjustable 8dB loss to 18dB gain (L & R adjust)
Common Mode Rejection:	>66dB typically
Input impedance:	>20kΩ bridging
Output impedance:	<50Ω
Distortion:	0.01% THD @ 1kHz, ref +8dBu output
Noise:	-100dB unity gain, ref +8dBu output

Connections	
Inputs:	2 x XLR 3 pin female (balanced, can be unbalanced)
Outputs:	12 x XLR 3 pin male (balanced, can be unbalanced)
Mains Input:	Filtered IEC, switchable 110-120V, or 220-240V, fused, 6W max
Fuse Rating:	Anti-surge fuse 100mA 20 x 5mm (230VAC) Anti-surge fuse 250mA 20 x 5mm (115VAC)
Equipment Type	
RB-DA6:	6 way stereo distribution amplifier
Physical Specification	
Dimensions (Raw):	48cm (W) x 10.8cm (D) x 4.2cm (H) (1U) 19" (W) x 4.3" (D) x 1.7" (H) (1U)
Dimensions (Boxed):	58.5cm (W) x 22.5cm (D) x 7cm (H) 23" (W) x 8.9" (D) x 2.8" (H)
Weight:	Nett: 1.3kg Gross: 1.9kg Nett: 2.9lbs Gross: 4.2lbs





## RB-DA6G 6 Way Stereo Distribution Amplifier With Output Gain Control



**Typical Applications:** Distribute line level signals to multiple reporters in a broadcast centre, distribute main programme output from a mixer to other studios, create multiple feeds of a recorded signal at different output levels.

**Category:** Audio Distribution Amplifiers.  
**Product Function:** Audio distribution to multiple destinations.

**Features:** Output level adjustment, mono/stereo switch, Neutrik XLR audio connectors.

The RB-DA6G is a 1U rack-mount high performance 6 way stereo distribution amplifier for splitting a source into a number of different outputs. It is identical to the RB-DA6 with the addition of individual output gain adjustment, instead of global stereo gain adjustment.

### Specification For RB-DA6G

#### Audio Specification

Maximum Input Level:	+28dBu
Maximum Output Level:	+28dBu
Frequency Response:	20Hz to 20kHz $\pm 0.1$ dB (600 $\Omega$ load, ref 1kHz)
Gain Range:	Adjustable 8dB loss to 18dB gain (12 adjustable pots)
Common Mode Rejection:	>66dB typically
Input impedance:	>20k $\Omega$ bridging

Output impedance:	<50 $\Omega$
Distortion:	0.01% THD @ 1kHz, ref +8dBu output
Noise:	-88dB unity gain, ref +8dBu output
<b>Connections</b>	
Inputs:	2 x XLR 3 pin female (balanced, can be unbalanced)
Outputs:	12 x XLR 3 pin male (balanced, can be unbalanced)
Mains Input:	Filtered IEC, switchable 110-120V, or 220-240V, fused, 6W max
Fuse Rating:	Anti-surge fuse 100mA 20 x 5mm (230VAC) Anti-surge fuse 250mA 20 x 5mm (115VAC)
<b>Equipment Type</b>	
RB-DA6G:	6 way stereo distribution amplifier with output gain control
<b>Physical Specification</b>	
Dimensions (Raw):	48cm (W) x 10.8cm (D) x 4.2cm (H) (1U) 19" (W) x 4.3" (D) x 1.7" (H) (1U)
Dimensions (Boxed):	58.5cm (W) x 22.5cm (D) x 7cm (H) 23" (W) x 8.9" (D) x 2.8" (H)
Weight:	Nett: 1.3kg Gross: 1.9kg Nett: 2.9lbs Gross: 4.2lbs





## RB-DA6P 6 Way Stereo Distribution Amplifier With Phoenix Connectors

The RB-DA6P is a version of the RB-DA6 audio distribution amplifier which uses Neutrik Phoenix style connectors instead of XLR inputs and outputs. Each unit is shipped with the mating connectors so that wires can be simply terminated using a small flat-blade screwdriver.

The inputs and outputs are electronically balanced and can be wired unbalanced. Each output is individually buffered so that a short circuit on one output won't affect the others.

The left and right input gain controls (normalising) are pre-set potentiometers accessible through the front panel.

The output gain may be varied from -8dB to 18dB which is useful for normalising consumer and professional signals to give outputs of -15dBu and 0dBu respectively.



**Category:** Audio Distribution Amplifiers.  
**Product Function:** Audio distribution to multiple destinations.

**Typical Applications:** Distribute line level signals to multiple reporters in a broadcast centre, distribute main programme output from a mixer to other studios.

**Features:** Input level adjustment, mono/stereo switch, Neutrik Phoenix style audio connectors.

### Specification For RB-DA6P

Audio Specification	
Maximum Input Level:	+28dBu
Maximum Output Level:	+28dBu
Frequency Response:	20Hz to 20kHz $\pm 0.1$ dB (600 $\Omega$ load, ref 1kHz)
Gain Range:	Adjustable 8dB loss to 18dB gain (L & R adjust)
Common Mode Rejection:	>66dB typically
Input impedance:	>20k $\Omega$ bridging
Output impedance:	<50 $\Omega$
Distortion:	0.01% THD @ 1kHz, ref +8dBu output
Noise:	-100dB unity gain, ref +8dBu output

### Connections

Inputs:	2 x Phoenix 3 pin (balanced, can be unbalanced)
Outputs:	12 x Phoenix 3 pin (balanced, can be unbalanced)
Mains Input:	Filtered IEC, switchable 110-120V, or 220-240V, fused, 6W max
Fuse Rating:	Anti-surge fuse 100mA 20 x 5mm (230VAC) Anti-surge fuse 250mA 20 x 5mm (115VAC)

### Equipment Type

RB-DA6P: 6 way stereo distribution amplifier with Phoenix connectors

### Physical Specification

Dimensions (Raw):	48cm (W) x 10.8cm (D) x 4.2cm (H) (1U) 19" (W) x 4.3" (D) x 1.7" (H) (1U)
Dimensions (Boxed):	58.5cm (W) x 22.5cm (D) x 7cm (H) 23" (W) x 8.9" (D) x 2.8" (H)
Weight:	Nett: 1.3kg Gross: 1.9kg Nett: 2.9lbs Gross: 4.2lbs







## RB-DA6R 6 Way Stereo Distribution Amplifier With RJ45 Connectors



**Category:** Audio Distribution Amplifier.

**Product Function:** Audio distribution to multiple destinations over CAT5 cabling.

**Typical Applications:** Distribute line levels signals to multiple reporters in a broadcast centre, distribute main programme output from a mixer to

other studios using a pre-wired CAT5 infrastructure, create multiple feeds of a recorded signal.

**Features:**

- Input level adjustment (RB-DA6R).
- Individual output gain adjustment for each channel (RB-DA6RG).
- Mono/stereo switch.
- Multiple input connections.
- Fast wiring using RJ45 connectors and Cat 5 cabling

The RB-DA6R is a 1U rack-mount high performance 6 way stereo distribution amplifier for splitting a source into a number of different outputs. The amplifier provides multiple balanced audio outputs using RJ45 connectors wired to the StudioHub+™ standard \*.

By using RJ45 outputs, it allows simpler CAT5 cabling to be used to connect the amplifier to other products.

The RB-DA6R has one stereo input which is switchable via a rear panel push switch between paralleled balanced inputs (2 x XLR sockets or 1 x stereo input on RJ45) and unbalanced inputs (1 pair of stereo phono sockets).

The unit has 6 stereo outputs on 6 x RJ45 connectors. The unit can also be configured so that 1 mono input can be distributed to 12 outputs by use of a switch which is recessed on the front panel to prevent it being accidentally knocked.

The inputs and outputs are electronically balanced and can be wired unbalanced. Each output is individually buffered so that a short circuit on one output won't affect the others. The left and right input gain controls (normalising) are pre-set potentiometers accessible through the front panel.

The output gain may be varied from -8dB to 18dB which is useful for normalising consumer and professional signals to give outputs of -15dBu and 0dBu respectively.



\* StudioHub+™ is a registered trademark of Radio Systems Inc





## RB-DA6RG 6 Way Stereo Distribution Amplifier With RJ45 Connectors & Output Gain Control



The RB-DA6RG is a 1U rack-mount high performance 6 way stereo distribution amplifier for splitting a source into a number of different outputs.

It is identical to the RB-DA6R with the addition of individual output gain adjustment, instead of global stereo gain adjustment.

\* StudioHub+™ is a registered trademark of Radio Systems Inc

### Specification For RB-DA6R & RB-DA6RG

#### Audio Specification

Maximum Input Level:	+28dBu
Maximum Output Level:	+28dBu
Frequency Response:	20Hz to 20kHz ±0.1dB (600Ω load, ref 1kHz)
Gain Range (RB-DA6R):	Adjustable 8dB loss to 18dB gain (L & R adjust)
Gain Range (RB-DA6RG):	Adjustable 8dB loss to 18dB gain (12 adjustable pots)
Common Mode Rejection:	>66dB typically
Input impedance:	>20kΩ bridging (balanced) >10kΩ (unbalanced)

Output impedance:	<50Ω
Distortion:	0.01% THD @ 1kHz, ref +8dBu output
Noise:	-100dB unity gain, ref +8dBu output
<b>Connections</b>	
Inputs:	2 x XLR 3 pin female, 1 x RJ45 socket (balanced) 2 x phono sockets (unbalanced)
Outputs:	6 x RJ45 sockets (all balanced, can be unbalanced)
Mains Input:	Filtered IEC, switchable 110-120V, or 220-240V, fused, 6W max
Fuse Rating:	Anti-surge fuse 100mA 20 x 5mm (230VAC) Anti-surge fuse 250mA 20 x 5mm (115VAC)

#### Equipment Type

RB-DA6R:	6 way stereo distribution amplifier with RJ45 connectors
RB-DA6RG:	6 way stereo distribution amplifier with RJ45 connectors & output gain control

#### Physical Specification

Dimensions (Raw):	48cm (W) x 10.8cm (D) x 4.2cm (H) (1U) 19" (W) x 4.3" (D) x 1.7" (H) (1U)
Dimensions (Boxed):	58.5cm (W) x 22.5cm (D) x 7cm (H) 23" (W) x 8.9" (D) x 2.8" (H)
Weight:	Nett: 1.3kg Gross: 1.9kg Nett: 2.9lbs Gross: 4.2lbs

#### Accessories

RB-RK3:	1U Rear panel rack kit for large Redboxes
---------	---



## RB-DA4x5 4 Input, 4 x 5 Output Distribution Amplifier/Mixer



**Category:** Audio Distribution Amplifier.

**Product Function:** Mixing & distribution of 4 mono analogue audio inputs to 4 sets of 5 mono outputs.

**Typical Applications:** Distribute line level signals to multiple reporters in a broadcast centre, at a radio station to distribute a PC automation output to up to 5 studios, to distribute a main programme output from a mixer to other studios, to create multiple mix minus feeds or to create multiple stereo to mono outputs.

**Features:**

- 4 input, 20 output distribution amplifier.
- Audio presence LED's for inputs or outputs.
- Balanced I/O that can be wired unbalanced.
- Outputs a 1kHz test tone e.g to check transmission lines.
- Front panel cover to secure settings.
- Input and output gain adjustment.

The RB-DA4x5 is a 1U rack-mount combined distribution amplifier and mixer. It has 4 mono analogue audio inputs on female XLR and 4 groups of 5 outputs on 15 way D-type connectors.

Each output group has a five way front-panel DIP switch assigned to it which is used to select the input(s) to send to the output group. This enables each of the four inputs, or a 1kHz OdBu tone, to be mixed to the output group.



The inputs and outputs are electronically balanced and can be wired unbalanced. Each input has adjustable gain using a pre-set potentiometer, providing a gain range of -8dB to +18dB.

Each output is individually buffered so that a short circuit on one output won't affect

the others. The output gain of each group can similarly be adjusted between -8dB and +18dB using pre-set potentiometers.

The DIP switch settings and gain controls are recessed beneath a front-mounting screw-on cover so that settings can not be accidentally altered, for secure applications.

Four bright front-panel signal present LEDs show the levels of either the inputs or the output groups by pressing the AUDIO PRESENCE button. The LEDs will show green illumination from -12db through to 0db, amber from 0db through to +6db and red for inputs and outputs at +6db and over.

**Specification For RB-DA4X5**

Audio Specification	
Maximum Input Level:	+28dBu
Maximum Output Level:	+28dBu
Frequency Response:	20Hz to 20kHz ±0.1dB (600Ω load, ref 1kHz)
Input Gain Range:	Adjustable 8dB loss to 18dB gain (channel 1-4 adjust)
Output Gain Range:	Adjustable 8dB loss to 18dB gain (group 1-4 adjust)
Input impedance:	>20kΩ bridging
Output impedance:	<50Ω
Distortion:	0.01% THD @ 1kHz, ref +8dBu output
Noise:	-100dB unity gain, ref +8dBu output
Common Mode Rejection:	>66dB typically
Connections	
Inputs (4 x Mono):	4 x XLR 3 pin female (balanced, can be unbalanced)
Outputs (20 x Mono):	4 x 15 way D-type male plug (balanced, can be unbalanced)
Mains Input:	Filtered IEC, switchable 110-120V, or 220-240V, fused, 9W max
Fuse Rating:	Anti-surge fuse 100mA 20 x 5mm (230VAC) Anti-surge fuse 250mA 20 x 5mm (115VAC)
Equipment Type	
RB-DA4x5:	4 Input, 4 x 5 output distribution amplifier/mixer
Physical Specification	
Dimensions (IU)	48cm (W) x 15.8cm (D*) x 4.2cm (H) (1U)
(Raw):	19" (W) x 6.2" (D*) x 1.7 (H) (1U)
Dimensions (Boxed):	59cm (W) x 27.5cm (D*) x 11cm (H) (23.2" (W) x 10.8" (D*) x 4.3" (H)
Weight:	Nett: 1.6kg Gross: 2.2kg Nett: 3.5lbs Gross: 4.8lbs

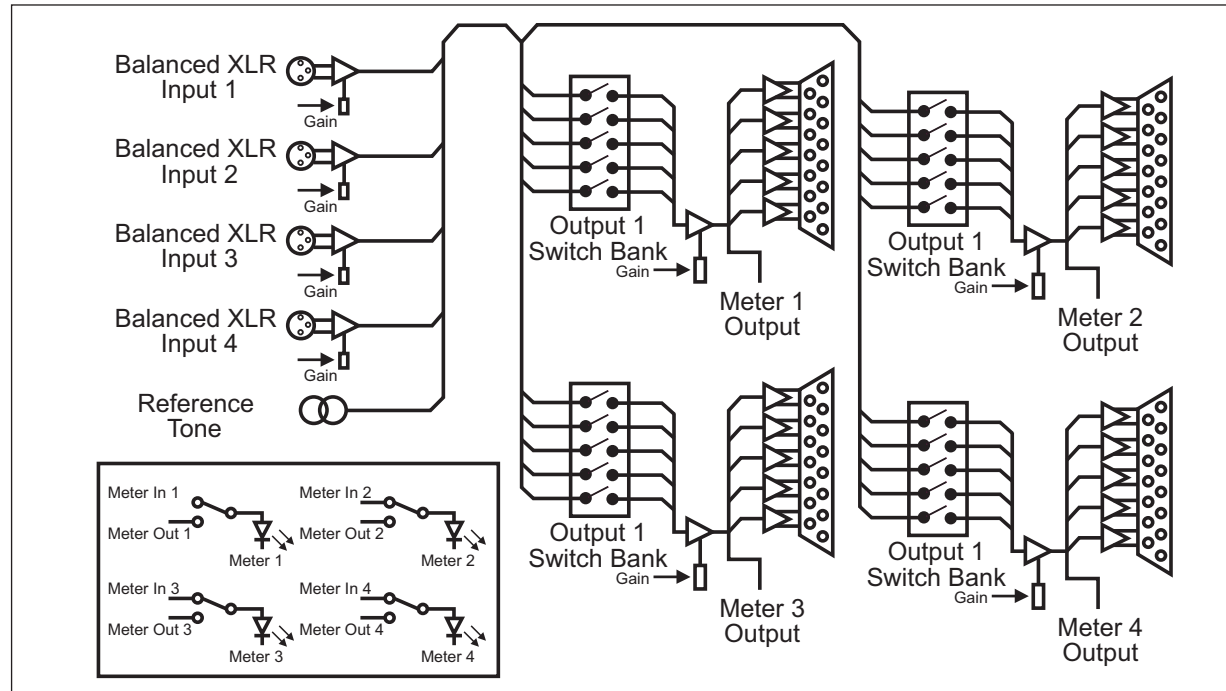

RB-DA4x5 Block Diagram.



## RB-DDA6A 6 Way Stereo AES/EBU Digital Distribution Amplifier



24<sup>BIT</sup>  
96<sup>kHz</sup>



**Category:** Audio Distribution Amplifiers.

**Product Function:** 1 input, 6 output AES/EBU digital audio distribution amplifier.

**Typical Applications:** Distribution of audio from a digital mixing desk to multiple digital recorders, or feeding multiple studios with an output from a flashcard player.

**Features:** Neutrik XLR input and output connectors, sample rates up to 96kHz.

The RB-DDA6A digital distribution amplifier is used for distributing digital audio data in AES/EBU format, repeating both the audio data and the status information of the input whilst re-normalising to standard digital audio levels.

It has a single XLR-3 female AES/EBU audio input which is distributed to 6 XLR-3 male AES/EBU outputs.

Applications include distributing audio from a digital mixing desk to multiple digital recorders, or feeding multiple studios with an output from a flashcard player.

It can accept input sample rates in the range of 30kHz - 100kHz, and bit rates of 16, 20 and

24 bit. So, it can be used for standard CD signal distribution at 16 bit 44.1kHz, as well as for high quality 24 bit 96kHz recording.

### Specification For RB-DDA6A

#### Audio Specification

Input Impedance: 110Ω ±20% balanced

Output Impedance: 110Ω ±20% balanced

Sample Freq Range: 30-100kHz (i.e. including 32kHz, 44.1kHz, 48kHz, 64kHz, 88.2kHz & 96kHz)

Signal Level: 2V/7V peak to peak min/max

#### Connections

Input: 1 x AES/EBU XLR 3 pin female (Balanced)

Outputs: 6 x AES/EBU XLR 3 pin male (Balanced)

Mains Input: Filtered IEC, switchable 110-120V, or 220-240V, fused, 6W max

Fuse Rating: Anti-surge fuse 100mA 20 x 5mm (230VAC)  
Anti-surge fuse 250mA 20 x 5mm (115VAC)

#### Equipment Type

RB-DDA6A: 6 way stereo AES/EBU digital distribution amplifier

#### Physical Specification

Dimensions (Raw): 28cm (W) x 10.8cm (D) x 4.2cm (H) (1U)  
11" (W) x 4.3" (D) x 1.7" (H) (1U)

Dimensions (Boxed): 36cm (W) x 20.5cm (D) x 6cm (H)  
14.2" (W) x 8" (D) x 2.4" (H)

Weight: Nett: 0.95kg Gross: 1.4kg  
Nett: 2.1lbs Gross: 3.2lbs





## RB-DDA6A-2P 6 Way Stereo AES/EBU Digital Distribution Amplifier with Dual Power Supplies

The RB-DDA6A-2P digital distribution amplifier is used for distributing digital audio data in AES/EBU format, repeating both the audio data and the status information of the input whilst re-normalising to standard digital audio levels.

It has a single XLR-3 female AES/EBU audio input which is distributed to 6 XLR-3 male AES/EBU outputs.

Applications include distributing audio from a digital mixing desk to multiple digital

recorders, or feeding multiple studios with an output from a flashcard player.

It can accept input sample rates in the range of 30kHz - 100kHz, and bit rates of 16, 20 and 24 bit. So, it can be used for standard CD signal distribution at 16 bit 44.1kHz, as well as for high quality 24 bit 96kHz recording.

The unit provides redundancy protection by using two power supply units that can be supplied from separate mains feeds. The

unit automatically load shares between the two supplies so that if either supply should fail the unit will continue to work correctly. If both supplies fail the input is connected directly to output 1.

The condition of the two supplies is indicated on the front panel by two red LEDs which illuminate to indicate the correct function of the supply. On the alarm output connector there is a changeover relay to indicate the status of each supply. This is normally closed to indicate power fail and once the supply is working correctly the relay activates to make a normally open contact.

### Specification For RB-DDA6A-2P

#### Audio Specification

Input Impedance:	110Ω ±20% balanced
Output Impedance:	110Ω ±20% balanced
Sample Freq Range:	30-100kHz (i.e. including 32kHz, 44.1kHz, 48kHz, 64kHz, 88.2kHz and 96kHz)
Signal Level:	2V/7V peak to peak min/max

#### Connections

Audio Inputs:	1 x AES/EBU XLR 3 pin female (balanced)
Audio Outputs:	6 x AES/EBU XLR 3 pin male (balanced)
Alarm Outouts:	2 x Relay output indicators on 1 x 9 pin D-Type socket
Mains Input:	2 x Filtered IEC, 85-264V switchable, fused, 6W max
Fuse Rating:	2 x Anti-surge fuse 1A 20 x 5mm

#### Equipment Type

RB-DDA6A-2P:	6 way AES/EBU stereo digital distribution amplifier with dual power supplies
--------------	--

#### Physical Specification

Dimensions (Raw):	48cm (W) x 10.8cm (D) x 4.2cm (H) (1U) 19" (W) x 4.3" (D) x 1.7" (H)(1U)
Dimensions (Boxed):	58.5cm (W) x 22.5cm (D) x 7cm (H) 23" (W) x 8.9" (D) x 2.8" (H)
Weight:	Nett: 1.5kg Gross: 2.0kg Nett: 3.3lbs Gross: 4.4lbs







## RB-DDA6S 6 Way Stereo S/PDIF Digital Distribution Amplifier



**Category:** Audio Distribution Amplifiers.

**Product Function:** 1 input, 6 output S/PDIF digital audio distribution amplifier.

**Typical Applications:** Audio distribution at 16 bit 44.1kHz from a consumer CD player to multiple digital recorders, distribution of high quality 24 bit 96kHz signals from digital mixing desks to recorders and connection of the output of, say, a BluRay player to multiple studios.

**Features:** Fully buffered outputs, sample rates up to 96kHz.



The RB-DDA6S digital distribution amplifier is similar to the RB-DDA6A except that it is used for distributing digital audio data in S/PDIF format.

It has a single S/PDIF audio input which is distributed to 6 x S/PDIF audio outputs at the same level and condition as the input signal. It can accept input sample rates in the range of 30kHz - 100kHz, and bit rates of 16, 20 and 24 bit.

Uses include audio distribution at 16 bit 44.1kHz from a consumer CD player to multiple digital recorders, distribution of high quality 24 bit 96kHz signals from digital mixing desks to recorders and connection of the output of, say, a BluRay player to multiple studios.

### Specification For RB-DDA6S

#### Audio Specification

Input Impedance:	75Ω ±5% unbalanced
Output Impedance:	75Ω ±5% unbalanced
Sample Freq. Range:	30-100kHz (i.e. including 32kHz, 44.1kHz, 48kHz, 64kHz, 88.2kHz & 96kHz)
Signal Level:	Balanced min 0.5V ±20% peak to peak

#### Connections

Input:	1 x S/PDIF RCA phono (unbalanced)
Outputs:	6 x S/PDIF RCA phono (unbalanced)
Mains Input:	Filtered IEC, switchable 110-120V, or 220-240V, fused, 6W max
Fuse Rating:	Anti-surge fuse 100mA 20 x 5mm (230VAC) Anti-surge fuse 250mA 20 x 5mm (115VAC)

#### Equipment Type

RB-DDA6S:	6 way stereo S/PDIF digital distribution amplifier
-----------	--

#### Physical Specification

Dimensions (Raw):	28cm (W) x 10.8cm (D) x 4.2cm (H) (1U)
Dimensions (Boxed):	11" (W) x 4.3" (D) x 1.7" (H) (1U)
Dimensions (Boxed):	36cm (W) x 20.5cm (D) x 6cm (H)
Dimensions (Boxed):	14.2" (W) x 8" (D) x 2.4" (H)
Weight :	Nett: 0.9kg    Gross: 1.35kg Nett: 2lbs    Gross: 3lbs



## RB-DDA6W 6 Way Word Clock Distribution Amplifier



**Category:** Audio Distribution Amplifiers.

**Product Function:** 1 input, 6 output TTL word clock distribution amplifier.

**Typical Applications:** Distribution of word clock signal from a master generator to other studio equipment to keep them synchronised.

**Features:** Fully buffered outputs.

The RB-DDA6W word clock distribution amplifier distributes a word clock BNC input signal to 6 word clock BNC outputs re-conditioned. It is used to distribute reference clocks for digital audio systems.

It has a single female BNC audio input which is distributed to 6 female BNC outputs.

The units primary application is to distribute a master TTL word clock source to multiple pieces of equipment that need to be synchronised from the master.

### Specification For RB-DDA6W

Audio Specification	
Input	50Ω
Impedance:	
Output	<50Ω
Impedance:	
Connections	
Input:	1 x BNC female
Outputs:	6 x BNC female
Mains Input:	Filtered IEC, switchable 110-120V, or 220-240V, fused, 6W max
Fuse Rating:	Anti-surge fuse 100mA 20 x 5mm (230VAC) Anti-surge fuse 250mA 20 x 5mm (115VAC)

Equipment Type	
RB-DDA6W:	6 way word clock distribution amplifier
Physical Specification	
Dimensions (Raw):	28cm (W) x 10.8cm (D) x 4.2cm (H) (1U) 11" (W) x 4.3" (D) x 1.7" (H) (1U)
Dimensions (Boxed):	36cm (W) x 20.5cm (D) x 6cm (H) 14.2" (W) x 8" (D) x 2.4" (H)
Weight:	Nett: 0.9kg Gross: 1.35kg Nett: 2lbs Gross: 3lbs



## RB-DDA6W-2P 6 Way Word Clock Distribution Amplifier with Dual Power Supplies



Category: Audio Distribution Amplifiers.  
Product Function: 1 input, 6 output TTL

word clock distribution amplifier.

**Typical Applications:** Distribution of word clock signal from a master generator to other studio equipment to keep them synchronised.

**Features:** Fully buffered outputs, dual IEC mains inputs.

The RB-DDA6W-2P word clock distribution amplifier distributes a word clock BNC input signal to 6 word clock BNC outputs re-conditioned. It is used to distribute reference clocks for digital audio systems.

It has a single female BNC audio input which is distributed to 6 female BNC outputs. The units primary application is to distribute a master TTL word clock source to multiple pieces of equipment that need to be synchronised from the master.

The unit provides redundancy protection by using two power supplies that can be supplied from separate mains feeds. The unit automatically load shares between the two supplies so that if either supply should fail, it will continue to work correctly. If both supplies fail, the input is connected directly to output 1.

The condition of the two supplies is indicated on the front panel by two red LEDs which illuminate to indicate the correct function of the supply. On the alarm output connector there is a changeover relay to indicate the status of each supply. This is normally closed to indicate power fail and once the supply is working correctly the relay activates to make a normally open contact.

### Specification For RB-DDA6W-2P

<b>Audio Specification</b>	
Input impedance:	50Ω
Output impedance:	<50Ω
<b>Connections</b>	
Audio Inputs:	1 x BNC female
Audio Outputs:	6 x BNC female
Alarm Outputs:	2 x Relay output indicators on 1 x 9 pin D-Type socket
Mains Input:	2 x Filtered IEC, 85-264V switchable, fused, 6W max
Fuse Rating:	2 x Anti-surge fuse 1A 20 x 5mm
<b>Equipment Type</b>	
RB-DDA6W-2P:	6 way word clock distribution amplifier with dual power supplies
<b>Physical Specification</b>	
Dimensions (Raw):	48cm (W) x 10.8cm (D) x 4.2cm (H) (1U)
	19" (W) x 4.3" (D) x 1.7" (H) (1U)
Dimensions (Boxed):	58.5cm (W) x 22.5cm (D) x 7cm (H)
	23" (W) x 8.9" (D) x 2.8" (H)
Weight:	Nett: 1.5kg Gross: 2.0kg
	Nett: 3.3lbs Gross: 4.4lbs





## RB-DDA6A3 6 Way Stereo AES3ID Digital Audio Distribution Amplifier



24<sup>BIT</sup>  
96<sup>kHz</sup>



**Category:** Audio Distribution Amplifiers.

**Product Function:** 1 input, 6 output AES3id digital audio distribution amplifier.

**Typical Applications:** Distribution of audio from a BluRay player to recorders, or feeding multiple studios with an output from a master clock.

**Features:** Fully buffered outputs, sample rates up to 96kHz.

The RB-DDA6A3 digital distribution amplifier is used for distributing AES3id digital audio, repeating both the audio data and the status information of the input whilst re-normalising to standard digital audio levels. It has a single BNC AES3id audio input which is distributed to 6 BNC AES3id audio outputs.

Applications include distributing audio from a BluRay player to recorders, or feeding multiple studios with an output from a master clock.

It can accept input sample rates in the range of 30kHz - 100kHz, and bit rates of 16, 20 and 24 bit.

### Specification For RB-DDA6A3

Technical Specification	
<b>Audio Specification</b>	
Input impedance:	75Ω
Output impedance:	75Ω
Sample Freq Range:	30-100kHz (i.e. including 32kHz, 44.1kHz, 48kHz, 64kHz, 88.2kHz & 96kHz)
Signal Level:	1V ±20% peak to peak (output 1.17V to drive long cable lengths)
<b>Connections</b>	
Inputs:	1 x BNC female
Outputs:	6 x BNC female
Mains Input:	Filtered IEC, switchable 110-120V, or 220-240V, fused, 6W max
Fuse Rating:	Anti-surge fuse 100mA 20 x 5mm (230VAC) Anti-surge fuse 250mA 20 x 5mm (115VAC)

Equipment Type	
RB-DDA6A3:	6 way stereo AES3ID digital audio distribution amplifier
Physical Specification	
Dimensions (Raw):	28cm (W) x 10.8cm (D) x 4.2cm (H) (1U) 11" (W) x 4.3" (D) x 1.7" (H) (1U)
Dimensions (Boxed):	36cm (W) x 20.5cm (D) x 6cm (H) 14.2" (W) x 8" (D) x 2.4" (H)
Weight:	Nett: 0.95kg    Gross: 1.4kg Nett: 2.1lbs    Gross: 3.2lbs



## RB-DDA22 Digital Audio Distribution Amplifier With Multiple Outputs

The RB-DDA22 is a multiple input and multiple output digital audio distribution amplifier designed to accept one of 5 different digital inputs and output to 22 digital audio outputs of 5 different connector types.

It is used for distributing digital audio data in many formats, repeating both the audio data and the status information of the input whilst re-clocking the data and re-normalising to the appropriate standard digital audio levels.

### Input Signals:

- 1 x XLR-3 female AES/EBU digital audio input
- 1 x BNC AES-3id digital audio input
- 1 x RJ45 AES/EBU digital audio input
- 1 x RCA Phono S/PDIF input
- 1 x TosLink digital audio optical input

### Output Signals:

- 6 x XLR-3 male AES/EBU digital audio outputs
- 6 x BNC AES-3id digital audio outputs
- 6 x RJ45 AES/EBU digital audio outputs
- 2 x RCA Phono S/PDIF outputs
- 2 x TosLink optical outputs

The RJ-45 connectors are wired to be StudioHub+ compatible, a format defined by Radio Systems Inc.

Applications include distributing audio from a digital mixing desk to multiple digital

recorders, or feeding multiple studios with an output from a USB audio player.

It can accept input sample rates in the range of 30kHz - 200kHz, and bit rates of 16, 20 and 24 bit. So, it can be used for standard CD signal distribution at 16 bit 44.1kHz, as well as for high quality 24 bit 96kHz or 192kHz recording.

The front panel has an INPUT SELECT button and 7 indicator LEDs. The button is used to select the input to be used and shows the mode of operation of the unit. The LEDs will indicate, depending on the mode of operation, the input selected, valid signal presence, or the operational frequency.

In 'operating mode', the central button LED is unlit. The unit selects this mode when a valid input signal has been present and no button presses have been made for 8 seconds. The LEDs around the button illuminate amber to directly indicate the following frequencies 32, 44.1, 48, 88.2, 96, 176.4 & 192 kHz. If the input is at a non-standard frequency then the unit will indicate both the frequencies either side of the incoming frequency – e.g. if the input signal has a frequency of 64kHz then both the 48kHz and 88.2kHz LEDs will be illuminated. If the frequency is below 32kHz

or above 192kHz then the appropriate LED will flash.

Pressing the INPUT SELECT central button illuminates it red and allows you to select the required input. Pressing the button will step the selected input to the next input selection including auto mode.

In Input Select Mode the LEDs have the following states:

**Off** – Signal not selected & no valid signal.  
**Green** – Signal not selected & valid signal.  
**Red** – Signal selected & no valid signal.  
**Amber** – Signal selected & valid signal present or Auto Mode Selected.

**Note:** Input Select mode is chosen automatically when the selected input is not present.

In this special input select mode the unit will hunt through all the inputs until it finds a valid signal. If multiple signals are present you can force selection of the next input by holding the input select button down for 2 seconds, when the next valid input will be selected.



**Typical Applications:** Distribution of an AES/EBU output to many recorders with different digital inputs. General tool for studio digital audio distribution.

### Features:

- Multiple input formats.
- Multiple output formats.
- Sample rates up to 192kHz.
- Front panel input selection.

**Category:** Audio Distribution Amplifiers.  
**Product Function:** Multi input, multi output format, digital audio distribution amplifier.





**Specification For RB-DDA22**

Audio Specification	
Input & Output Impedances:	110Ω ±20% AES/EBU balanced I/O 75Ω ±5% S/PDIF unbalanced I/O
Signal Level:	Balanced: 3V/10V peak to peak min/max Unbalanced: Min 0.5V±20% peak to peak
Sample Frequencies:	32, 44.1, 48, 88.2, 96,176.4 or 192kHz
Bit Depth:	Up to and including 24 bit
Front Panel Operational Controls & Indicators	
Digital Input Select:	AES/EBU (XLR), AES/EBU (BNC), AES/EBU (RJ45), S/PDIF or TOSlink optical
Indicators:	Input presence indicators via tricolour LEDs around the input select button

Connections	
Digital Inputs:	1 x AES/EBU XLR 3 pin socket 1 x AES/EBU BNC 1 x AES/EBU RJ45 socket (StudioHub+™) 1 x S/PDIF RCA phono socket 1 x TOSLink optical input
Digital Outputs:	6 x AES/EBU XLR 3 pin plug 6 x AES/EBU BNC 6 x AES/EBU RJ45 socket (StudioHub+™) 2 x S/PDIF RCA phono socket 2 x TOSLink optical output
Mains Input:	Universal filtered IEC, continuously rated 85-264VAC@47- 63Hz, max 10W
Fuse Rating:	Anti-surge fuse 1A 20 x 5mm

Equipment Type	
RB-DDA22:	Digital audio distribution amplifier with multiple outputs
Physical Specification	
Dimensions (Raw):	48cm (W) x 10.8cm (D) x 4.2cm (H) (1U) 19" (W) x 4.3" (D) x 1.7" (H) (1U)
Dimensions (Boxed):	58.5cm (W) x 22.5cm (D) x 7cm (H) 23" (W) x 8.9" (D) x 2.8" (H)
Weight:	Nett: 1.4kg Gross: 2.0kg Nett: 3.0lbs Gross: 4.4lbs
Accessories	
RB-RK3:	1U Rear panel rack kit for large Redboxes

\* StudioHub+™ is a registered trademark of Radio Systems Inc



## RB-DA24MD 24 Way Mono Audio Distribution Amplifier



**Category:** Audio Distribution Amplifiers.

**Product Function:** Mixing & distribution of 2 mono analogue audio inputs to 24 mono outputs.

**Typical Applications:** Distribute mono emergency audio signals to multiple powered monitors, to distribute a mono

source (e.g. mic input converted to line) to many outputs, e.g. at a news conference.

**Features:**

- 2 input, 24 output distribution amplifier.
- Input gain adjustment.
- Balanced I/O that can be wired unbalanced.
- Use as a stereo pair, or 2 x mono inputs.
- High pass roll-off filter.
- Output protection against PoE & phantom power.
- Mixed output level adjustment.

The RB-DA24MD is a 1U rack mount high performance 24 way audio distribution amplifier. It has 2 inputs which can be each individually routed to 12 outputs, or mixed and routed to all 24 outputs.

The inputs can be configured as either dual mono, input 1 routed to outputs 1-12 and input 2 routed to outputs 13-24, or mixed-

mono, inputs 1 and 2 mixed at a pre-set level and routed to all 24 outputs.

When set to mixed-mono operation there are 3 different output mix level modes, enabled by altering internal jumpers, providing -6dB, -3dB or 0dB adjustment of the output.

The XLR inputs and D-type outputs are electronically balanced and can be wired unbalanced. Each output is individually buffered so that a short circuit on one won't affect the others.

Each output is also protected against connection to both POE (power over Ethernet) and phantom power circuits.

The RB-DA24MD has master gain controls for both input 1 and input 2 which are pre-set potentiometers accessible through the rear panel. These controls allow the gain to be adjusted from -15dB to +15dB, useful

for normalising consumer to professional signals and vice versa.

A 125Hz 6dB per octave roll off filter is activated by a push switch on the rear panel. When selected the filter is the applied to both inputs.

An LED power indicator on the front panel shows that the unit is powered.

### Specification For RB-DA24MD

Audio Specification	
Input impedance:	>20k $\Omega$ bridging (balanced)
Output impedance:	<50 $\Omega$
Maximum Input Level:	+28dBu
Maximum Output Level:	+28dBu
Frequency Response:	20Hz to 20kHz $\pm$ 0.1dB (600 $\Omega$ load, ref 1kHz)
Gain Range:	Adjustable -15dB loss to +15dB gain
Common Mode Rejection:	>66dB typically
LF Roll Off Filter:	125Hz at 6dB/octave
Distortion:	0.01%THD @ 1kHz, ref +8dBu output
Noise:	-100dB unity gain, ref +8dBu output

### Connections

Inputs:	2 x XLR 3 pin female (balanced)
Outputs:	2 x 25 way D-type plug (balanced, can be unbalanced)
Mains Input:	Filtered IEC, switchable 110-120V, or 220-240V, fused, 12W maximum
Fuse Rating:	Anti-surge fuse 100mA 20 x 5mm (230VAC) Anti-surge fuse 250mA 20 x 5mm (115VAC)

### Equipment Type

RB-DA24MD:	24 way mono distribution amplifier
------------	------------------------------------

### Physical Specification

Dimensions (Raw):	48cm (W) x 15.8cm (D) x 4.2 (H) (1U) 19" (W) x 6.2" (D) x 1.7" (H) (1U)
Dimensions (Boxed):	58.5cm (W) x 27.4cm (D) x 10.8cm (H) 23" (W) x 10.9" (D) x 4.3" (H)
Weight:	Nett: 1.6kg Gross: 2.2kg Nett: 3.5lbs Gross: 4.8lbs



## RB-AES4B3 Quad 3 Way Passive AES3ID Splitter BNC Connectors



**Category:** Audio Distribution Amplifiers.

**Product Function:** 4 sets of: 1 input, 3 output AES3id distribution amplifier.

**Typical Applications:** Distribution of AES3id source to 3 mixing consoles.

**Features:** No power needed, can apply 75Ω termination to unconnected outputs.

The RB-AES4B3 is a passive, quad “one-to-three” splitter housed in a 19” rack. Each bank is designed to split a single AES3ID digital audio source to up to three destinations, using female BNC connectors.

Particularly useful in a video production and broadcast environment, the RB-AES4B3 splits the input signal through high quality transformers.

75Ω termination can be applied, if desired, to unconnected outputs to maintain optimum carrier parameters.

The RB-AES4B3 requires no power to operate, ensuring your audio remains connected from source to destination(s) without interruption from power failures.

### Specification For RB-AES4B3

#### Audio Specification Cable Drive Capability

Cumulative cable drive capability of 100m of 75Ω coaxial cable at sample rates up to and including 96kHz.

#### Connections

Inputs: 4 x BNC female  
Outputs: 12 x BNC female

#### Equipment Type

RB-AES4B3 Quad 3 way passive AES3ID splitter with BNC connectors.

#### Physical Specification

Dimensions (Raw):	48cm (W) x 10.8cm (D) x 4.2cm (H) (1U)
Dimensions (Boxed):	58.5cm (W) x 22.5cm (D) x 7cm (H)
Weight:	Nett: 1.0kg Gross: 1.4kg Nett: 2.25lbs Gross: 3.0lbs







## RB-AES4X3 Quad 3 Way AES/EBU Splitter XLR Connectors

The RB-AES4X3 is a passive, quad “one-to-three” splitter housed in a 19” rack. Each bank is designed to split a single AES3 digital audio source to up to three destinations, using Neutrik XLR connectors.

The RB-AES4X3 provides solutions to a range of digital signal distribution problems, where correct termination is essential to

maintain signal integrity. The input signal is split through high quality transformers, and 110Ω termination can be applied, if desired, to unconnected outputs.

The RB-AES4X3 requires no power to operate, ensuring your audio remains connected from source to destination(s) without interruption from power failures.



Category: Audio Distribution Amplifiers.  
Product Function: 4 sets of: 1 input, 3

output AES3 distribution amplifier.  
**Typical Applications:** Distribution of AES3 source to 3 mixing consoles.  
**Features:** No power needed, can apply 110Ω termination to unconnected outputs, transformer based solution provides reliability.

### Specification For RB-AES4X3

#### Audio Specification Cable Drive Capability

The table below sets out the minimum signal amplitude required to drive 100m (cumulative) of 110Ω twisted pair cable, based on the sample rate of the digital audio:

Sample Rate	Minimum Signal Amplitude
32kHz	*2Vpk-pk
44.1kHz	*2Vpk-pk
48kHz	*2Vpk-pk
88.2kHz	5Vpk-pk
96kHz	5Vpk-pk

\* Minimum of 2Vpk-pk is defined by the AES3 format specification.

The table below sets out the minimum signal amplitude required to drive 30m (cumulative) of 110Ω twisted pair cable, based on the sample rate of the digital audio:

Sample Rate	Minimum Signal Amplitude
176.4kHz	3Vpk-pk
192kHz	3Vpk-pk

#### Connections

Inputs: 4 x XLR 3 pin female  
Outputs: 12 x XLR 3 pin male

#### Equipment Type

RB-AES4X3 Quad 3 way AES/EBU splitter with XLR connectors

#### Physical Specification

Dimensions (Raw):	48cm (W) x 10.8cm (D) x 4.2cm (H)(1U)
Dimensions (Boxed):	58.5cm (W) x 22.5cm (D) x 7cm (H)
Weight:	23" (W) x 8.9" (D) x 2.8" (H)
	Nett: 1.0kg Gross: 1.4kg
	Nett: 2.25lbs Gross: 3.0lbs







## RB-MS4X3 Quad 3 Way Passive Microphone Splitter



### Typical Applications:

To share microphones between radio/TV/production studios.

### Features:

- Passive transformer design.
- Ground lift switch.
- External or looped phantom power inputs.
- Line level -30dB pad.

**Category:** Audio Distribution Amplifiers.

**Product Function:** To split up to 4 microphone or line level signals to 3 independent outputs each.

The RB-MS4X3 is a passive, quad, “one-to-three” splitter housed in a 19” rack. Each bank is designed to split a single microphone or line source to up to three destinations, using Neutrik XLR connectors. Cable connections are located on the rear panel, with recessed controls and indicators available to the user on the front panel, allowing quick and easy access to setup parameters.

### Wide Signal Range Capability

The RB-MS4X3 uses high quality audio transformers that are capable of accepting input levels of up to +18dBu, making the splitter useful in both microphone and line level splitting applications. A 30dB pad can be applied to the input, allowing a line level signal to be interfaced into a microphone input with suitable levels and the correct termination.

### Versatile Phantom Powering Options

The RB-MS4X3 offers three methods of providing phantom power to a microphone connected to its input:



- From the external +48VDC power connector.
- From a microphone amplifier connected to output 1 (direct).
- From a microphone amplifier connected to output 2 (phantom loopback).

Controlling which method is used to provide phantom power is easy with front panel switches and indicators. It is possible to concurrently power a microphone using any two of the above methods without degrading audio performance, thus providing power supply redundancy.

### Ground Loop Hum Elimination

Ground loop hum problems can be quickly eliminated using the front panel toggle switches to lift pin 1 of the output connectors (output 2 and 3 only).

### Specification For RB-MS4X3

#### Audio Specification

Test	Conditions	Results
Frequency Response:	<ul style="list-style-type: none"> <li>• Ref. -6dBu, 1kHz</li> <li>• Source impedance = 150Ω</li> <li>• Load impedance = 10kΩ</li> </ul>	10Hz - 30kHz ±0.5dB
Total Harmonic Distortion:	<ul style="list-style-type: none"> <li>• Ref. +3dBu, 50Hz</li> <li>• Source impedance = 150Ω</li> <li>• Load impedance = 10kΩ</li> </ul>	0.02%
Total Harmonic Distortion 0.1%:	<ul style="list-style-type: none"> <li>• Ref. 0.1%THD+N, 50Hz</li> <li>• Source impedance = 150Ω</li> <li>• Load impedance = 10kΩ</li> </ul>	+13dBu
Total Harmonic Distortion 1%:	<ul style="list-style-type: none"> <li>• Ref. 1%THD+N, 50Hz</li> <li>• Source impedance = 150Ω</li> <li>• Load impedance = 10kΩ</li> </ul>	+18dBu
Common Mode Rejection Ratio:	<ul style="list-style-type: none"> <li>• Ref. 20kHz</li> <li>• Source impedance = 600Ω</li> <li>• Load impedance = 10kΩ</li> </ul>	>60dB

#### Connections

Inputs:	4 x XLR 3 pin female
Outputs:	12 x XLR 3 pin male
DC Phantom Power Input:	+48V DC, 2.5mm socket

#### Equipment Type

RB-MS4X3	Quad 3 way microphone splitter
----------	--------------------------------

#### Physical Specification

Dimensions (Raw):	48cm (W) x 10.8cm (D) x 4.2cm (H) (1U) 19" (W) x 4.3" (D) x 1.7" (H) (1U)
Dimensions (Boxed):	58.5cm (W) x 22.5cm (D) x 7cm (H) 23" (W) x 8.9" (D) x 2.8" (H)
Weight:	Nett: 1.5kg Gross: 1.9kg Nett: 3.3lbs Gross: 4.2lbs



## RB-MSP6 6 Way +48V Phantom Power Supply



**Category:** Phantom Power Supplies.

**Product Function:** Providing multiple +48V power outputs.

**Typical Applications:** Connecting to multiple RB-MSP6 microphone splitters to ensure phantom power redundancy for connected microphones.

**Features:**

- Dual redundant IEC power inlets.
- 6 x locking DC output connectors for +48V phantom power.

The RB-MSP6 is a 1U rack-mount phantom power supply, designed to be used in conjunction with up to six RB-MS4X3s,

providing mains input redundancy to ensure the target microphones remain powered in the event of a single mains failure.

Two mains AC inlets power separate 48V supplies that are diode fed to six locking DC connector outputs. Each output connector is individually protected with a resettable fuse rated at 50mA, so a fault on one output will not affect the others.

Should either of the 48V supplies fail, or if their AC power input is removed, the corresponding red front panel LED will extinguish, and a relay alarm output is provided on the rear panel D-Type.

### Specification For RB-MSP6

Mains Inputs:	2 x Filtered IEC, 90V-264V, 47-63Hz, fused, 20W maximum
Fuse Ratings:	2 x Anti-surge fuse 1A 20 x 5mm
Phantom Power Outputs:	6 x locking DC connectors, 2.5mm pin, 48V DC, 50mA maximum current, protected by resettable fuse.
<b>Equipment Type:</b>	
RB-MSP6:	6 way +48V phantom power supply
<b>Physical Specification:</b>	
Dimensions (Raw):	28cm (W) x 10.8cm (D) x 4.2cm (H) (1U) 11" (W) x 4.3" (D) x 1.7" (H) (1U)
Dimensions (Boxed):	36cm (W) x 20.5cm (D) x 6cm (H) 14.2" (W) x 8" (D) x 2.4" (H)
Weight:	Nett: 1.2kg Gross: 1.5kg Nett: 2.6lbs Gross: 3.3lbs
<b>Accessories:</b>	
RB-RK2:	1U rear panel rack kit for small Redbox range





## RB-HD1 Stereo Headphone Amplifier With VCA Volume Control

The RB-HD1 is a 1U rack-mount stereo headphone amplifier for driving up to two pairs of professional stereo headphones from a single stereo or mono input. One headphone socket is on the front panel with one on the rear.

The main stereo input uses electronically balanced XLR-3 connectors on the rear panel, which can be wired un-balanced. The output volume for the headphones can be controlled either by a pot situated on the front panel or a VCA signal supplied externally via the remote connector.

A mono input can be mixed into the main headphone feed, for example, for mixing in talkback to the headphones. This has an input level control via a recessed adjustable potentiometer. The mono mix input can also be controlled remotely.

A stereo/mono switch is recessed on the rear panel to prevent accidental knocking. With mono selected, audio is sent to both left and right ear pieces.

A LED power indicator on the front panel displays the power supply connection.



**Category:** Headphone Distribution Amplifiers.

**Product Function:** Provides a headphone output from a line level signal.

**Typical Applications:** Headphone monitoring for voice over booths, adding headphone output to mixer programme output.

**Features:**

- Front and rear headphone outputs.
- VCA remote level control.
- Stereo/mono selection.
- Mono talkback input.

### Specification For RB-HD1

Audio Specification	
Input Impedance:	>20kΩ balanced bridging (main)
Output Level:	Drives 150mW into 32Ω to 600Ω headphones
Mono Mix Input Gain Range:	22dBu
Max Input Level:	+28dBu
Volume Control:	-80dB to +11dB gain
Connections	
Main Stereo Inputs:	2 x XLR 3 pin female (balanced, can be unbalanced)
Mono Mix Input:	1 x XLR 3 pin female (balanced, can be unbalanced)

Outputs:	2 x ¼" (6.35mm) A-gauge 3-pole stereo jack sockets
Remote Control:	9-pin D-type socket
Mains Input:	Filtered IEC, switchable 110-120V, or 220-240V, fused, 9W max
Fuse Rating:	Anti-surge fuse 100mA 20 x 5mm (230VAC) Anti-surge fuse 250mA 20 x 5mm (115VAC)
Equipment Type	
RB-HD1:	Stereo headphone amplifier
Physical Specification	
Dimensions (Raw):	48cm (W) x 10.8cm (D) x 4.2cm (H) (1U) 19" (W) x 4.3" (D) x 1.7" (H) (1U)
Dimensions (Boxed):	58.5cm (W) x 22.5cm (D) x 7cm (H) 23" (W) x 8.9" (D) x 2.8" (H)
Weight:	Nett: 1.35kg Gross: 2.0kg Nett: 3lbs Gross: 4.4lbs







## RB-HD2 Dual Stereo Headphone Amplifier

The RB-HD2 is a high performance 2-way stereo headphone distribution amplifier for driving up to 2 pairs of professional stereo headphones from a single stereo or mono input.

A switch on the rear panel enables the distribution of a mono signal to all four outputs (i.e. both earpieces of a pair of stereo headphones) via the left channel input. The stereo/mono switch is located on the rear panel to prevent accidental knocking.

The XLR-3 inputs are electronically balanced and can be wired unbalanced. There are two pre-set controls on the rear panel that adjust the level of the master input signal to the outputs.

Each output is on a ¼" stereo jack socket and is designed to drive 150mW into 32 ohm to 600 ohm stereo headphones. The outputs are individually buffered with their own front panel volume control. A LED power indicator on the front panel displays the power supply connection.



Category: Headphone Distribution Amplifiers.

**Product Function:** Provides 2 headphone outputs from a line level signal.

**Typical Applications:** Adding headphone outputs to mixer programme output.

**Features:** Stereo/mono selection and input gain controls.

### Specification For RB-HD2

#### Audio Specification

Input Impedance:	>20kΩ balanced bridging (main)
Max Input Level:	+28dBu
Input Gain Range:	-12dB to +20dB gain (pre-set pots)
Output Level:	Drives 150mW into 32Ω to 600Ω headphones
Volume Controls:	-80dB to +11dB gain

#### Connections

Main Stereo Input:	2 x XLR 3 pin female (balanced, can be unbalanced)
--------------------	--

Outputs:	2 x ¼" (6.35mm) A-gauge 3-pole stereo jack sockets
Mains Input:	Filtered IEC, switchable 110-120V, or 220-240V, fused, 9W max
Fuse Rating:	Anti-surge fuse 100mA 20 x 5mm (230VAC) Anti-surge fuse 250mA 20 x 5mm (115VAC)
<b>Equipment Type</b>	
RB-HD2:	Dual stereo headphone amplifier
<b>Physical Specification</b>	
Dimensions (Raw):	48cm (W) x 10.8cm (D) x 4.2cm (H) (1U) 19" (W) x 4.3" (D) x 1.7" (H) (1U)
Dimensions (Boxed):	58.5cm (W) x 22.5cm (D) x 7cm (H) 23" (W) x 8.9" (D) x 2.8" (H)
Weight:	Nett: 1.35kg Gross: 2.0kg Nett: 3lbs Gross: 4.4lbs







## RB-HD6 6 Way Stereo Headphone Distribution Amplifier

The RB-HD6 headphone distribution amplifier is a 1U rack-mount which distributes stereo audio to up to 6 different sets of headphones, or can be used as 6 independent headphone amplifiers, each with their own input and volume control.

A typical application might be to provide common headphone feeds for guests in a radio studio, with a separately derived feed, perhaps including talk-back, for the presenter.

The main stereo input is on XLR-3 connectors on the rear panel which are electronically balanced and can be wired unbalanced. A stereo/mono input select switch on the rear panel sums left and right outputs to provide a mono feed to the headphones. The unit can receive an override audio signal via a jack socket for each output channel, allowing the unit to act as 6 single independent headphone amps. Plugging in the jack plug will divert the headphone output from the master audio signal to the audio present on the jack plug. The override audio inputs can also be individually configured as parallel outputs of

the front sockets, by setting internal jumpers.

The master volume control adjusts overall level of the 6 outputs and does not affect the level of channels using the override inputs. The master volume can be disabled by internal jumpers.

### Specification for RB-HD6

#### Audio Specification

Input Impedance:	>20kΩ balanced bridging, >10kΩ unbalanced override
Output Level:	Drives 150mW into 32Ω to 600Ω headphones
Individual Volume Control:	-60dB to +18dB gain
Max Input Level:	+28dBu
Override Inputs:	+3dBu for full volume at +18dB gain
Master Vol Control:	±10dB gain



Category: Headphone Distribution Amplifiers.

**Product Function:** Distributes a stereo line level signal to 6 x headphone outputs.  
**Typical Applications:** Provides multiple guest headphone outputs in a radio studio.  
**Features:** Individual & master volume controls, insert jacks on each output, paralleled outputs and mono/stereo switch.

#### Connections

Main Stereo Inputs:	2 x XLR 3 pin female (balanced, can be unbalanced)
Insert Inputs/ Parallel Outputs:	6 x ¼" (6.35mm) A-gauge 3-pole stereo jack sockets (unbalanced)
Outputs:	6 x ¼" (6.35mm) A-gauge 3-pole stereo jack sockets
Mains Input:	Filtered IEC, switchable 110-120V, or 220-240V, fused, 9W max
Fuse Rating:	Anti-surge fuse 100mA 20 x 5mm (230VAC) Anti-surge fuse 250mA 20 x 5mm (115VAC)

#### Equipment Type

RB-HD6:	6 way stereo headphone distribution amplifier
---------	---

#### Physical Specification

Dimensions (Raw):	48cm (W) x 10.8cm (D) x 4.2cm (H) (1U)
Dimensions (Boxed):	19" (W) x 4.3" (D) x 1.7" (H) (1U)
Dimensions (Raw):	58.5cm (W) x 22.5cm (D) x 7cm (H)
Dimensions (Boxed):	23" (W) x 8.9" (D) x 2.8" (H)
Weight:	Nett: 1.35kg Gross: 2.0kg Nett: 3lbs Gross: 4.4lbs





## RB-DHD6 Digital 6 Way Stereo Headphone Distribution Amplifier



Category: Headphone Distribution Amplifiers.

**Product Function:** Distributes a stereo digital line level signal to 6 x headphone outputs.

**Typical Applications:** Provides multiple guest headphone outputs from the digital output of a radio mixer or router matrix.

**Features:** Individual volume controls, AES/EBU or S/PDIF input switch.

The RB-DHD6 digital 6 way headphone distribution amplifier is a 1U rack-mount which receives a digital input signal, as either AES/EBU or S/PDIF and converts it to 6 individually buffered, jack-plug, headphone outputs, each with their own volume control.



Useful for connection to digital mixing desks, digital routers and matrices, the RB-DHD6 connects directly to an AES/EBU or S/PDIF output to provide the highest quality audio directly to the headphones.

The input connectors consist of a single balanced XLR-3 for the AES/EBU input and a single unbalanced phono connector for the S/PDIF input.

A button located on the rear panel is used to select either the AES/EBU, or S/PDIF, input and de-emphasis on the output can be controlled via dipswitch.

If de-emphasis is selected, the RB-DHD6 will decode 50/15µs emphasis when indicated by certain channel status bits in the incoming digital audio data.

When operating, the front panel power LED flashes red and amber whenever the unit is not synchronised to the incoming digital signal.

### Specification For RB-DHD6

#### Audio Specification

Output Level:	Drives 150mW into 32Ω to 600Ω headphones
Dynamic Range:	>100dB
Input Impedance:	110Ω ±20% AES/EBU 75Ω ±15% S/PDIF
Maximum Output Level:	+12dBu unbalanced
Headphone Gain Range:	-80dBu to +12dBu
Sample Frequency Range:	30kHz-100kHz
<b>Connections</b>	
Digital Inputs:	1 x AES/EBU XLR 3 pin female, 1 x S/PDIF RCA phono
Headphone Outputs:	6 x ¼" (6.35mm) A/B-gauge 3-pole stereo jack sockets
Mains Input:	Filtered IEC, 110V-120V, or 220-240V, fused, 10W max

Fuse Rating:	Anti-surge fuse 100mA 20 x 5mm (230VAC) Anti-surge fuse 250mA 20 x 5mm (115VAC)
--------------	--

#### Operational Controls

De-emphasis On/Off:	DIP switch selection
Digital Input Select:	AES/EBU or S/PDIF, via push-switch

#### Equipment Type

RB-DHD6:	Digital 6 way stereo headphone distribution amplifier
----------	---

#### Physical Specification

Dimensions (Raw):	48cm (W) x 10.8cm (D) x 4.2cm (H) (1U) 19" (W) x 4.3" (D) x 1.7" (H) (1U)
Dimensions (Boxed):	58.5cm (W) x 22.5cm (D) x 7cm (H) 23" (W) x 8.9" (D) x 2.8" (H)
Weight:	Nett: 1.6kg Gross: 2.2kg Nett: 3.5lbs Gross: 4.8lbs



## RB-SS10 10 Way Stereo Analogue Source Selector/Mixer



**Category:** Mixers, Source Selectors & Switchers.

**Product Function:** Mixes or routes up to 10 stereo inputs to one stereo output with front panel & remote button control.

**Typical Applications:** For monitoring multiple stereo audio sources, as a studio on-air switcher.

**Features:**

- Individual channel gain controls.
- Mix mode available.
- Optional channel selection through remote control.
- Front panel selection Inhibit.
- Headphone monitoring of output.
- Simultaneous routing of GPIO with audio.

The RB-SS10 10 way stereo analogue source selector/mixer is a 1U rack-mount unit that produces a stereo analogue audio output from 10 selectable stereo analogue sources. There are 10 illuminated front panel push-buttons, which select and indicate the current channel selection. The selection and indication is also available through a remote connector on the rear panel. To stop accidental front panel selection there is a remote input to inhibit the front panel buttons.

Two of the stereo inputs are on XLR so that you can hot-plug audio sources, e.g. portable recorders.

As well as being able to act as a source select module, the RB-SS10 can act as a mixer, by enabling the mix mode (using the remote input).

The gain for left and right inputs can be individually adjusted by using the pre-set potentiometers on the front panel.

As well as routing the selected audio signal, the unit will also route a remote signal input through the remote connector to the selected input source, for starting external audio equipment such as a CD player.

The front panel headphone output has its own volume control, which is independent of the level adjustment for the main outputs, and has a maximum output level of +12dBu.

The volume control can be made to also alter the output level of the main XLR outputs by using a switch on the rear panel to enable/disable this feature.

There is a designation strip on the front panel, useful for giving the buttons a meaningful description. The strip covers the input gain controls so that once configured, they can't easily be altered - ideal for installation work.

The LED on the front panel is used to indicate that power is present on the unit.

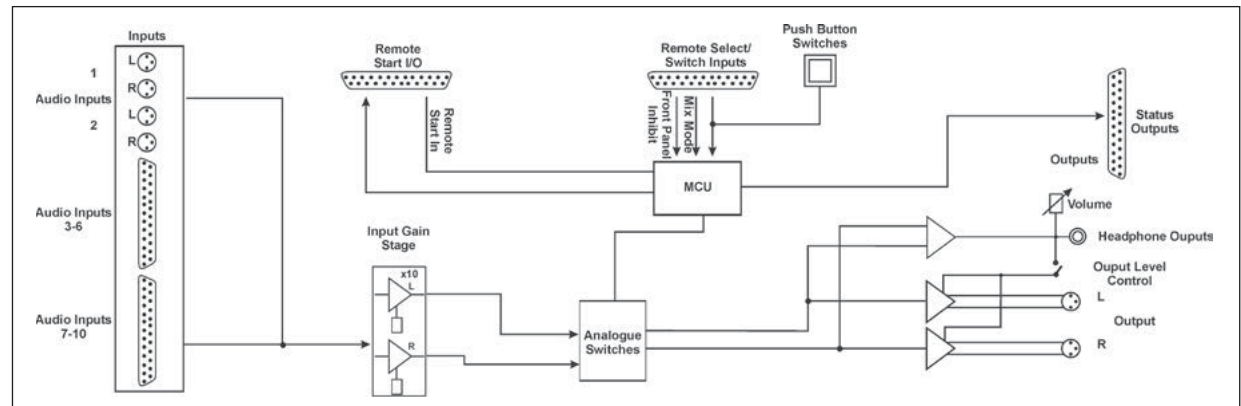

RB-SS10 Flowchart.

### Specification For RB-SS10

Audio Specification	
Input Impedance:	20kΩ bridging
Output Impedance:	<50Ω
Maximum Input Level:	+28dBu
Maximum Output Level:	+28dBu
Frequency Response:	20Hz to 20kHz ±0.1dB (600Ω load, ref 1kHz)
Input Gain Range:	Adjustable 8dB loss to 20dB gain (L & R adjust).
Common Mode Rejection:	>66dB typically
Noise:	-96dB unity gain ref +8dBu
Max Headphone Output Level:	+12dBu

Connections	
Inputs:	4 x XLR 3 pin female (2 x stereo) (balanced, can be unbalanced) 2 x 25 way D-type socket (female) (4 stereo balanced channels on each)
Outputs:	2 x XLR 3 pin male (stereo balanced, can be unbalanced)
Remote Start I/O:	25 way D-type plug (male)
Remote Select/Switch Inputs:	25 way D-type socket (female)
Status Outputs:	25 way D-type socket (female)
Mains Input:	Filtered IEC, 110V-120V, or 220-240V switchable, fused, 6W maximum.
Fuse Rating:	Anti-surge fuse 160mA 20 x 5mm (230VAC) Anti-surge fuse 315mA 20 x 5mm (115VAC)

Equipment Type	
RB-SS10:	10 way stereo analogue source selector/mixer
Physical Specifications	
Dimensions (Raw):	48cm (W) x 10.8cm (D) x 4.2cm (H) (1U) 19" (W) x 4.3" (D) x 1.7" (H) (1U)
Dimensions (Boxed):	58.5cm (W) x 22.5cm (D) x 7cm (H) 23" (W) x 8.9" (D) x 2.8" (H)
Weight:	Nett: 1.5kg Gross: 2.0kg Nett: 3.3lbs Gross: 4.4lbs





## RB-DSS10 10 Way Stereo Digital Source Selector



**Category:** Mixers, Source Selectors & Switchers.

**Product Function:** 10 stereo digital input source selection unit to 1 stereo output.

**Typical Applications:** Switching the broadcast output from digital mixers in multiple studios.

**Features:**

- Both AES/EBU & S/PDIF I/O.
- Individual channel gain controls.
- Optional channel selection via remote control.
- Front panel selection inhibit.
- Headphone monitoring of output.
- Routing of remote inputs with selected audio channel.

The RB-DSS10 digital source selector is a 1U rack-mount which produces an AES/EBU and S/PDIF level digital audio output from 10 selectable AES/EBU or S/PDIF digital input signals. There are 10 illuminated front panel push-buttons, which select and indicate the current channel selection. The selection and indication is also available through a remote connector on the rear panel. To stop accidental front panel selection there is a remote input to inhibit the front panel buttons.

The digital receivers in this unit are fully 24 bit, 96kHz capable. When an input is selected from the front panel, or remotely, the unit will attempt to capture the incoming signal on either the AES/EBU or the S/PDIF signal inputs, with priority given to the AES/EBU input. If the AES/EBU signal becomes locked while the S/PDIF signal is routed, the unit will automatically switch to the incoming AES/EBU signal.

Once the receiver has successfully locked to a digital input, the LED illuminates, the tally is made, and the audio is routed simultaneously to both the digital audio outputs and converted to analogue for monitoring on the front panel

headphone socket. If the incoming audio signal is not present, the push-button LED and remote tally flash to indicate that the incoming digital signal is missing.

The headphone output has its own volume control, which is independent of the level adjustment for the main outputs, and has a maximum output level of +12dBu.

As well as routing the selected audio signal, the unit will also route a remote signal input through the remote connector to the selected input source, for starting external audio equipment, such as a CD player.

There is a designation strip on the front panel, useful for giving the buttons a meaningful description.

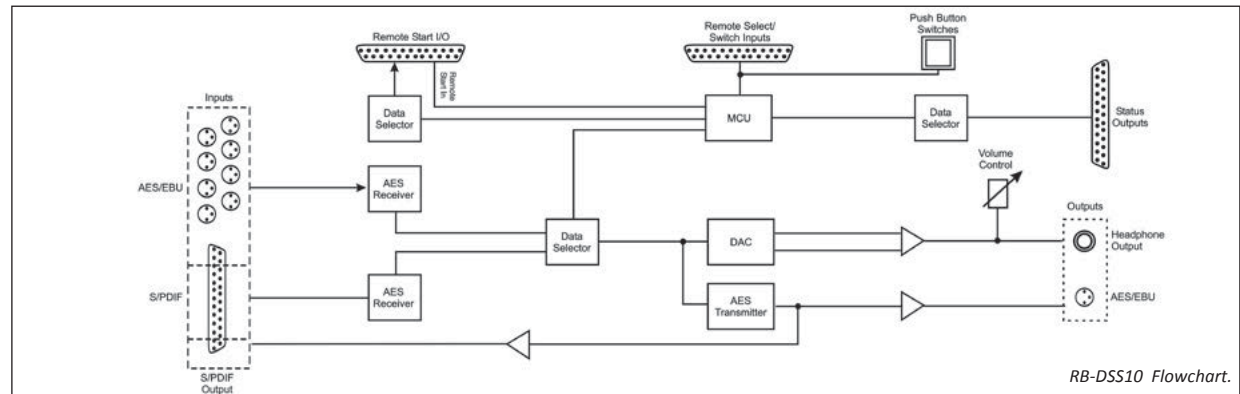

RB-DSS10 Flowchart.



The LED on the front panel is used to indicate that power is present on the unit. However, it also has a secondary role to indicate whether the selected channel is routing the AES/EBU (red LED) or S/PDIF input (amber LED).

### Specification For RB-DSS10

#### Audio Specification

Input Impedance:	110Ω ±20% balanced (AES/EBU) 75Ω ±5% unbalanced (S/PDIF)
Output Impedance:	110Ω ±20% balanced (AES/EBU) 75Ω ±5% unbalanced (S/PDIF)
Signal Level:	3V/10V peak to peak min/max (AES/EBU) 0.5V ±20% peak to peak (S/PDIF)
Sample Freq Range:	30-100kHz (i.e. including 32kHz, 44.1kHz, 48kHz, 64kHz, 88.2kHz and 96kHz), following input signal
Bit Depth:	Up to and including 24 bits, following input signal
Max Headphone Output Level:	+12dBu











#### Connections

Audio Inputs:	8 x AES/EBU XLR 3 pin female 2 x AES/EBU (part of 1 x 25 way D-type plug) 10 x S/PDIF (part of 1 x 25 way D-type plug)
Audio Outputs:	1 x AES/EBU XLR 3 pin male 1 x S/PDIF (part of 1 x 25 way D-type plug)
Remote Start I/O:	1 x 25 way D-type plug (male)
Remote Input Select & Switch Inputs:	1 x 25 way D-type socket (female)
Status Outputs:	1 x 25 way D-type socket (female)
Headphone Outputs:	6 x ¼" (6.35mm) A-gauge 3-pole stereo jack sockets

Mains Input:	Filtered IEC, continuously rated 85-264VAC @ 47-63Hz, max 10W
Fuse Rating:	Anti-surge fuse 1A 20 x 5mm
<b>Equipment Type</b>	
RB-DSS10	10 way stereo digital source selector
<b>Physical Specifications</b>	
Dimensions (Raw):	48cm (W) x 10.8cm (D) x 4.2cm (H) (1U) 19" (W) x 4.3" (D) x 1.7" (H) (1U)
Dimensions (Boxed):	58.5cm (W) x 22.5cm (D) x 7cm (H) 23" (W) x 8.9" (D) x 2.8" (H)
Weight:	Nett: 1.6kg Gross: 2.2kg Nett: 3.5lbs Gross: 4.8lbs



## RB-PMX4 10 Input, 4 Output Analogue Pre-set Mixer

    	<p><b>Typical Applications:</b> Four bus mini-mixer, a multiple clean-feed generator, a 4 zone mixer for pubs and clubs and a quad stereo to mono converter.</p> <p><b>Features:</b></p> <ul style="list-style-type: none"><li>• Neutrik XLR I/O.</li><li>• Individual input channel gain controls.</li><li>• Total flexibility for routing/mixing signals.</li><li>• Simple to use and configure.</li><li>• Front panel cover for secure applications.</li></ul>
    	

**Category:** Mixers, Source Selectors & Switchers.

**Product Function:** 10 mono input to 4 mono output mixer/router.

The RB-PMX4 is a high performance 10 mono input to 4 mono output pre-set mixer. Each of the four outputs has a 10 way DIP switch associated with it to select which of the 10 inputs are routed to it. So, by altering the DIP switches, any of the input sources can be mixed to any of the outputs. The DIP switches are enclosed by a screw-on cover on the front panel so that the settings can not be accidentally changed for secure applications.



The RB-PMX4 has been designed for situations where a small mixer is needed for installations where it will be configured and then only altered occasionally, or never altered at all.

Uses for this product are numerous including a four bus mini-mixer, a multiple clean-feed generator, a 4 zone mixer for pubs and clubs and a quad stereo to mono converter to name a few.

The XLR-3 inputs and outputs are electronically balanced and can be wired unbalanced. Each output is individually buffered so that a short circuit on one won't affect the others.

Each input has its own gain control which is a pre-set potentiometer accessible through the front panel. This provides gain adjustment of -8dB to +18dB. This is useful for normalising consumer and professional signals to give outputs of -15dBu and 0dBu respectively.

### Specification For RB-PMX4

#### Audio Specification

Input Impedance:	>20kΩ balanced bridging
Maximum Input Level:	+36dBu
Frequency Response:	20Hz to 20kHz ±0.1dBu (600Ω load, @ 1kHz)
Common Mode Rejection:	>60dBu typically
Noise:	-86dBu RMS 22Hz-22kHz unity gain, ref +8dBu
Output Impedance:	<50Ω
Maximum Output Level:	+28dBu
Gain Range:	Adjustable -8dBu to +18dBu gain
Off-isolation/ Crosstalk:	>90dBu @ 1kHz
Distortion:	<0.01% @ 1kHz, 0dBu to +26dBu

#### Connections

Inputs:	10 x XLR 3 pin female (Balanced, can be unbalanced)
Outputs:	4 x XLR 3 pin male (Balanced, can be unbalanced)
Mains Input:	Filtered IEC, switchable 110-120V, or 220-240V, fused, 6W maximum
Fuse Rating:	Anti-surge fuse 100mA 20 x 5mm (230VAC) Anti-surge fuse 250mA 20 x 5mm (115VAC)

#### Equipment Type

RB-PMX4:	10 input, 4 output analogue pre-set Mixer
----------	---

#### Physical Specification

Dimensions (Raw):	48cm (W) x 10.8cm (D) x 4.2cm (H) (1U) 19" (W) x 4.3" (D) x 1.7" (H) (1U)
Dimensions (Boxed):	58.5cm (W) x 22.5cm (D) x 7cm (H) 23" (W) x 8.9" (D) x 2.8" (H)
Weight:	Nett: 1.5kg    Gross: 2.2kg Nett: 3.3lbs    Gross: 4.8lbs



## RB-DMX4 4 x 4 Channel Digital Audio Mixer/Router

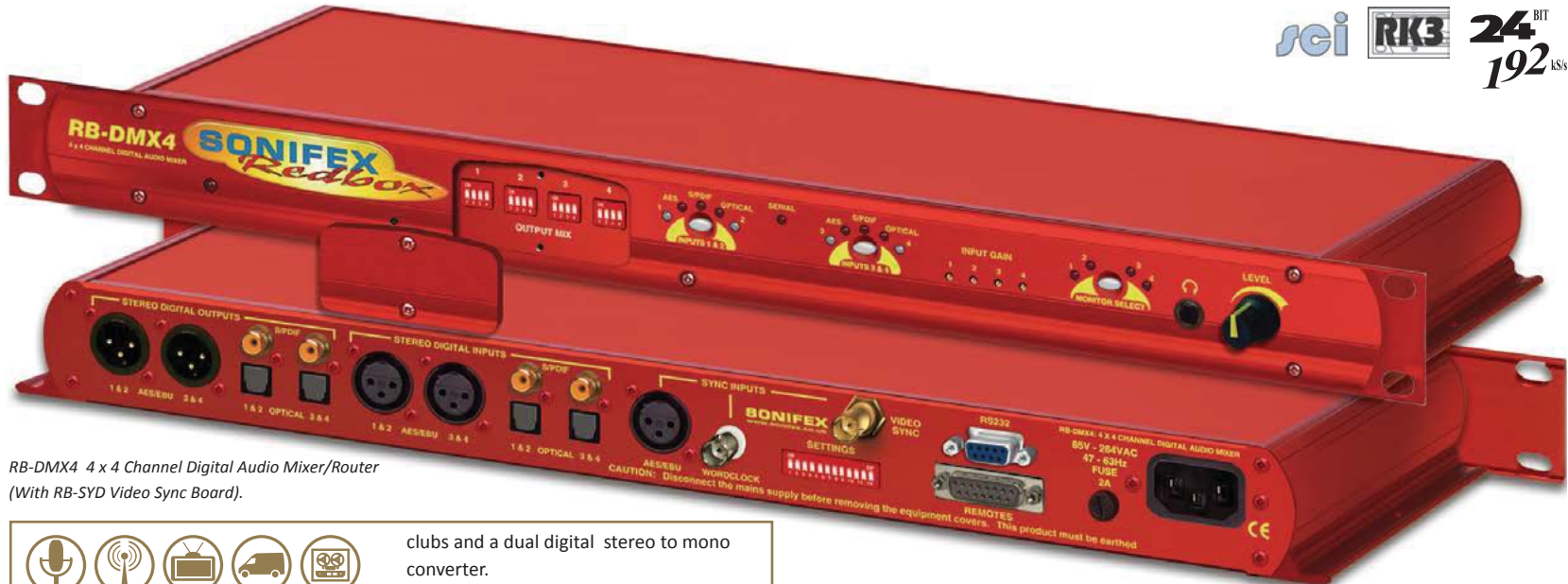

RB-DMX4 4 x 4 Channel Digital Audio Mixer/Router  
(With RB-SYD Video Sync Board).



**Category:** Mixers, Source Selectors & Switchers.

**Product Function:** 4 mono digital inputs to 4 mono digital outputs mixer/router.

**Typical Applications:** Four bus digital mini-mixer, multiple digital clean-feed generator, a 4 zone mixer for pubs and

clubs and a dual digital stereo to mono converter.

**Features:**

- Passive signal path.
- AES/EBU, S/PDIF & Toslink I/O.
- Headphone output with input selector.
- Input & output presence indicators.
- Input channel gain controls.
- TTL wordclock & AES/EBU sync inputs.
- Optional sync cards can be added.
- Mono or stereo operation.
- Total flexibility for routing/mixing signals.
- Front panel cover for secure applications.

The RB-DMX4 is a digital mixer capable of mixing or routing 4 mono input channels into 4 mono outputs, or 2 stereo inputs into 2 stereo outputs. The inputs are sample rate converted to allow sources of different sample rates to be mixed. The flexible Mix Matrix allows for a wide variety of mixing options and creativity, using 4 blocks of 4 way DIPswitches to select which inputs are mixed or routed to which outputs.

The RB-DMX4 has 4 x digital mono audio inputs, selectable in pairs via front panel INPUTS 1 & 2 and INPUTS 3 & 4 push buttons, from either AES/EBU balanced XLRs, S/PDIF unbalanced phonos or Toslink unbalanced optical inputs. Sample rate converters on each input mean that sources of different sample rates can be used with the output sample rate being defined independently. The colour of the INPUTS 1 & 2 and INPUTS 3 & 4 push-buttons indicate



whether the input source is synchronised (no colour) or not (flashing green and red).

Each input has a trim pot, which can be used to attenuate the input signal. This allows for a perfect mix of channels at different audio levels. Audio presence LEDs around each input button give an indication of input audio level. There is one LED for each channel. There are also 4 presence LEDs around the MONITOR button which give an indication of output level. Additional gain can be added by accessing the OUTPUT GAIN mode.

There are 2 stereo outputs which are available as simultaneous AES/EBU balanced XLRs, S/PDIF unbalanced phonos or Toslink unbalanced optical outputs. The output sample rates are selectable via rear panel DIPswitches from one of 32kHz, 44.1kHz, 48kHz, 88.2kHz, 96kHz, 176.4kHz or 192kHz.

The unit has TTL wordclock BNC and AES/EBU XLR synchronising inputs as standard and optionally, the RB-SYA and RB-SYD synchronisation boards can be fitted to synchronise the unit to analogue or digital video signals. A rear panel DIPswitch block is used to decide whether the unit is synchronised to Input 1 & 2, Input 3 & 4, the AES/EBU sync input, the wordclock sync input or an optional video sync board. The DIPswitch block also selects the synchronisation mode of the unit and the MONITOR button flashes whenever the unit is not synchronised to an incoming sync signal. Selectable sync modes are as follows:

**Master Mode** - In this mode the digital output sample rate is simply set by, and

locked to, the internal on-board clock generator. No sync signal is used or required.

**Auto Sync Mode** - In this mode the digital output sample rate follows the selected sync input. When the sync signal is not present the output sample rate will be set by, and locked to, the internal on-board clock generator at the selected output frequency.

**Auto Lock Mode** - The digital output sample rate follows the sync input. If the sync signal is removed then the output sample rate will be set by, and locked to, the internal on-board clock generator at the closest frequency available to the previous sync input.

**Slave Mode** - In this mode the digital output sample rate follows the sync input. When the sync signal is not present the digital output is turned off.

There is a monitor socket on the front panel with a gain pot to allow you to monitor the output of each channel. The monitored channel can be selected via a push button on the front panel which, when held, can also supply up to 12dB of gain. If the level that is being monitored is close to full scale, a 12dB attenuation can be added to the monitor output via a DIPswitch on the rear panel.

The unit can be placed in mono or stereo mode via rear panel DIPswitch. Stereo mode allows you to monitor the two input pairs as stereo channels as well as controlling the input gain as a pair, giving tied audio levels.

The RB-DMX4 has been designed to have a passive signal path through the main input,

so if power to the unit fails, signal inputs 1 & 2 are routed to outputs 1 & 2 and signal inputs 3 & 4 are routed to outputs 3 & 4.

This is essential for applications such as installation at transmitter sites, where a power failure to the unit should not prevent the audio input signal from being output to the transmitter. Please note that this is not true for the Toslink outputs which are muted.

The RB-DMX4 can be controlled using Sonifex free software, SCI. Contact Sonifex for further information if you have a particular requirement that isn't catered for by the RB-DMX4 as standard.

### Specification For RB-DMX4

Audio Specification	
Dynamic Range:	>138dB
Distortion and Noise:	<-137dB THD + N at 1kHz, ref 0dB FS
Input & Output Impedances:	110Ω ±20% AES/EBU balanced I/O 75Ω ±5% S/PDIF unbalanced I/O 75Ω ±5% Toslink unbalanced I/O 50Ω BNC TTL word clock input
Signal Level:	Balanced: 3V/10V peak to peak min/max Unbalanced: Min 0.5V±20% peak to peak
Sample Frequencies:	32, 44.1, 48, 88.2, 96, 176.4 or 192kHz
Bit Depth:	Up to and including 24 bit
Front Panel Operational Controls & Indicators	
Digital Input Select:	AES/EBU, S/PDIF or Toslink optical via INPUT 1 & 2 or INPUT 3 & 4 push-buttons
Mix Control:	Output mix selection system via front panel DIPswitches
Input Gain:	Input gain control for four INPUT channels via potentiometers, from muted (∞) to unity gain
Output Gain:	Adjustable via front panel push switch to 0dB, 3dB, 6dB or 12dB
Monitor Select Control:	Headphone monitor channel select and output gain via push button
Indicators:	Input and output presence indicators via bicolour LEDs around each push button

Rear Panel Operational Controls	
Master Select:	32, 44.1, 48, 88.2, 96, 176.4 or 192kHz Frequency via rear panel DIPswitches
Sync Source Select:	INPUTS 1&2, INPUTS 3&4, AES Sync, Word Clock, Video Sync via rear panel DIPswitches
Sync Mode Select:	Master, Auto Sync, Auto Lock, Slave via rear panel DIPswitches
Stereo Features:	Stereo gain control and monitor outputs via rear panel DIPswitches
Monitor Attenuation:	12dB Monitor attenuation via rear panel DIPswitches
Serial Mode:	Enter serial control mode via rear panel DIPswitches
Boot Mode:	Boot up base code or firmware via rear panel DIPswitches

Connections	
Digital Inputs:	2 x AES/EBU XLR 3 pin female 2 x S/PDIF RCA phono 2 x Toslink optical input
Digital Outputs:	2 x AES/EBU XLR 3 pin plug 2 x S/PDIF RCA phono socket 2 x Toslink optical output
Sync Inputs:	1 x AES/EBU XLR 3 pin female 1 x Word Clock BNC 1 x Video Input (optional)
Remote I/O Port:	15 way D-type plug
Serial Port:	RS232, 9 pin D-type socket
Mains Input:	Universal filtered IEC, continuously rated 85-264VAC@47- 63Hz, max 10W
Fuse Rating:	Anti-surge fuse 2A 20 x 5mm

Equipment Type	
RB-DMX4:	4 x 4 channel digital audio mixer/router
Physical Specifications	
Dimensions (Raw):	48cm (W) x 10.8cm (D*) x 4.2cm (H) (1U) 19" (W) x 4.3" (D*) x 1.7" (H) (1U)
Dimensions (Boxed):	59cm (W) x 27.5cm (D*) x 11cm (H) 23.2" (W) x 10.8" (D*) x 4.3" (H)
Weight:	Nett: 1.4kg Gross: 2.0kg Nett: 3.1lb Gross: 4.4lb

Accessories	
RB-SYA:	Analogue video sync board (NTSC, PAL & SECAM)
RB-SYD:	Digital video sync board (SD-SDI & HD-SDI)
RB-RK3:	1U Rear panel rack kit for large Redboxes

\* Note that this product is deeper than standard Redboxes



## RB-SSML1 Mic/Line Source Selector with Compressor/Limiter



**Category:** Mixers, Source Selectors & Switchers.

**Product Function:** Compressing or limiting an incoming mic or stereo line signal, mixing with a stereo monitor input for metering and mixing to two headphone outputs.

**Typical Applications:** Designed for voice-over & over-dubbing applications in voice-over booths/suites, use with audio codecs.

**Features:**

- Two headphone outputs.
- Mic high pass filter & phantom power.
- Wide mic gain range adjustment.
- Line inputs & outputs can be balanced or wired unbalanced.
- Compression ratio & threshold limits adjustment.
- Bright LED output level metering.

The RB-SSML1 is a 1U rack-mountable source selector for compressing or limiting an incoming microphone or stereo line signal and mixing this signal with a stereo monitor input, which can then be metered and mixed to two headphone outputs. The unit is mainly used in situations where level control is required, for example in voiceover applications.

The mic input consists of an independent low-noise microphone pre-amplifier for converting microphone level signals to a line level. There are independent switches to control a high pass filter (low frequency roll-off at 125Hz) and to provide phantom power at +48V to the connected microphone. A preset pot on the rear panel allows adjustment of the mic gain from 36dB to 75dB.

A front panel switch selects between mic & line inputs. Both mic and line inputs have fully adjustable volume control via front panel pots, with an additional 10dB gain increase for the line input via a rear panel switch, for use with unbalanced equipment. The mono mic input is converted to a stereo signal before being passed to the compressor/limiter.

The XLR-3 stereo monitor input has an adjustable volume control via a back panel recessed pot, and has an additional 10dB gain increase via a switch on the rear panel, for use with unbalanced equipment. The audio on this input is only present on the headphone outputs, and is therefore suitable as a return feed from a codec, a PC audio output, or similar equipment.

The compression ratio and threshold limits of the compressor/limiter section are fully adjustable via linear pots situated on the front panel. The threshold can be set between -30dBu and +20dBu. When the input signal rises above the threshold level a soft-knee compression is applied at the selected ratio. The compressor has an attack time of approximately 20ms and a release time of approx 400ms, and can operate at ratios of 1:1 (no compression) to :1 (limiting). A front panel BYPASS button can be used, where no compression is applied. A rear-panel DIPswitch allows compression only to be applied to the mic input and not the stereo line input.

The metering is carried out after the compressor/limiter section and consists of two rows of 12 round LEDs showing levels

between -17dB and +11dB. An internal jumper allows the metering to follow either the stereo output, or the headphone monitor outputs and a rear panel DIPswitch can disable the peak hold display.

The XLR-3 stereo line output can be fed from either the mic or line input, but not the stereo monitor input. The line output is electronically balanced and can be wired unbalanced by grounding the non-phase signal, allowing you to feed both balanced and unbalanced equipment. A pushbutton switch is provided to reduce the output by 10dB for this purpose.

An LED power indicator on the front panel displays the power supply connection.

**Specification For RB-SSML1**

Technical Specification		
Maximum Input Level:	-10dBu (mic), +28dBu (line), electronically balanced	
Input Impedance:	20kΩ nominal balanced	
Maximum Output Level:	+28dBu	
Output Impedance:	<50Ω	
Low Frequency	125Hz @ 6dB/octave	Roll-Off:
Gain Range (mic):	Adjustable 36dB to 75dB gain (-80dB volume min.)	
Volume Control (line):	-80dB to +6dB gain (-70dB +16dB with additional input gain)	
E.I.N.:	130dB	
Distortion:	<0.02% THD @ 1kHz, ref +8dBu output	
Common Mode Rejection:	>66dB typically	
Phantom Power:	48V	
Frequency Response:	20Hz to 20kHz ±0.3dB (600Ω load, ref 1kHz)	

Connections	
Mic Input:	1 x XLR 3 pin female (Balanced)
Line Input:	2 x XLR 3 pin female (Balanced)
Monitor Input:	2 x XLR 3 pin female (Balanced)
Output:	2 x XLR 3 pin male (Balanced, can be unbalanced)
Headphone Outputs:	2 x ¼" (6.35mm) A-gauge 3-pole stereo jack sockets
Mains Input:	Filtered IEC, 110V-120V, or 220-240V switchable, fused, 9W maximum
Fuse Rating:	Anti-surge fuse 100mA 20 x 5mm (230VAC) Anti-surge fuse 250mA 20 x 5mm (115VAC)

Equipment Type	
RB-SSML1:	Mic/Line source selector with compressor/limiter

Physical Specification	
Dimensions (Raw):	48cm (W) x 10.8cm (D) x 4.2cm (H) (1U) 19" (W) x 4.3" (D) x 1.7" (H) (1U)
Dimensions (Boxed):	58.5cm (W) x 22.5cm (D) x 7cm (H) 23" (W) x 8.9" (D) x 2.8" (H)
Weight:	Nett: 1.3kg Gross: 2.0kg Nett: 2.9lbs Gross: 4.4lbs

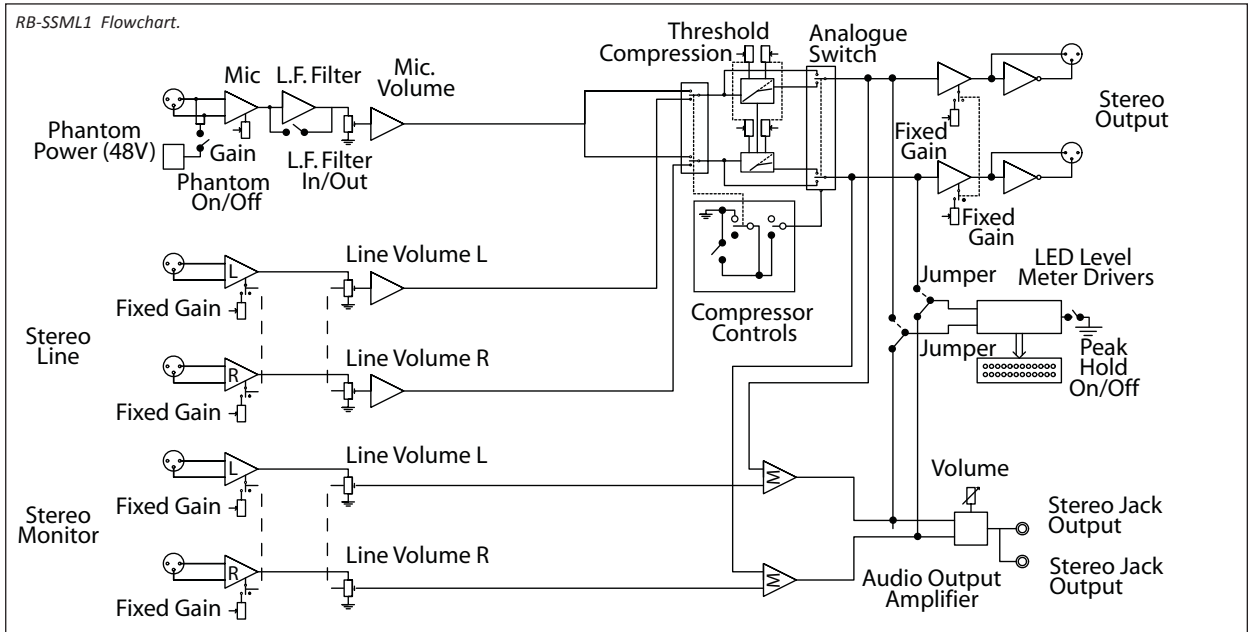



## RB-OA3 3 Studio On-Air Switcher



**Category:** Mixers, Source Selectors & Switchers.

**Product Function:** To switch the on-air transmission output between multiple radio studios.

**Typical Applications:** Designed for multi-studio switching & routing the studio output to the transmitter.

**Features:**

- Controls the offer/accept switching for 3 studios.
- Switches 3 stereo bidirectional channels so allows sharing of equipment between studios, e.g. studio output, codec clean-feeds, telco feeds & other equipment.
- Has a stereo transformer mix input, e.g. for playout system.
- Continuity mode allows switching to/from a PC playout system, so a 3rd studio can be used as sustaining service allowing other studios to be powered down for maintenance or power saving.
- Latching relay switching means transmission path remains intact on power-fail.
- Expandable to switch 6 stereo channels between 5 studios.
- Last studio to offer bus.

The RB-OA3 is a 1U rack-mount, unity gain on-air switcher, capable of switching three stereo pairs between three studios. Each studio can control the transmission path together with two peripheral paths for equipment such as a codec or hybrid and there is also a “Last studio to offer” bus, allowing for seamless and continuous broadcast from any multi-studio radio network. A “sustain” mode allows for a sustaining system, such as a PC automation system, to control the broadcast.

Multiple RB-OA3 units can be connected together to switch more studios or more stereo pairs.

The switching is achieved using relays, except the “last studio to offer” which is switched by an analogue switch. The transmission path is switched using latching relays. This means that if there is a power failure to the unit, the transmission path will remain selected.

All studios are connected using 25 way D-types for electronically balanced audio signals and control is achieved using 15 way D-types, connecting to an external control unit such as the Sonifex S2-MTBS mixer control panel. A transmission mix connection is included to mix audio which is generic to all studios into the transmission path. This could be used for jingles or adverts for example. The RB-OA3 also allows for the control of a profanity delay to be

shared by all connected studios.

Each studio has the ability to offer the transmission. Once offered, the transmission is fed to the other studios via the “last studio to offer” bus. The next scheduled station can then fade in the transmission and accept at the appropriate time meaning the transmission can be continuous.

The “sustain” mode can be used to control an automated studio, such as an overnight music system. In this case, station control will switch to the automated system by holding the Offer button down for a number of seconds, pre-determined by a calibration routine. This will select the sustaining studio, set as studio three, which will immediately offer control back to all remaining studios. Any studio can then accept to resume orthodox broadcasting.

The RB-OA3 can be expanded to switch between up to 5 studios or up to 6 stereo pairs by connecting a multiple of units together via RJ45 serial connections. With the addition of a single unit, expansion in “studio” mode allows for 2 additional studios to take control of the transmission path and additional equipment. If the expansion is made in “bus” mode, then three additional stereo channels can be added. 4 x RB-OA3 units can be connected together to switch 6 stereo pairs between up to 5 studios.

The modes are configured by dip switch configurations, on the rear of each unit. Two DIP switches control the unit ID and there are two switches which decide between “studio” and “bus” modes. A master unit, defined by a preset ID, conducts all communication between all units.

**Specification For RB-OA3**

<b>Audio Specification</b>	
<b>Transmission and Peripheral Path:</b>	
Relays are used for switching these specific paths leading to a passive, transparent audio path.	
<b>LSO Path:</b>	
Input Impedance:	>20kΩ
Output Impedance:	<50Ω
Gain Range:	Unity gain
Frequency Response:	20Hz to 20kHz ±0.1dB
Common Mode Rejection:	< -66dB typically
Distortion:	0.01%THD @ 1kHz
Noise:	-100dB unity gain, ref +8dBu
<b>Mix Audio Transformer Specifications:</b>	
Common Mode Rejection:	< -64dB @ 10kHz
Distortion:	0.5% THD ref 17dBu @ 40Hz
Bandwidth:	±0.5dBu 10Hz to 36kHz
<b>Connections</b>	
Studio I/O:	3 x 25 way D type socket (female)
Transmission I/O:	1 x 25 way D type socket (female)
Dump/Delay Control:	1 x 9 way D type plug (male)
Studio Control:	3 x 15 way D type sockets (female)
LSO Expansion Port:	1 x 9 way D type socket (female)
Mix Input:	1 x 9 way D type socket (female)
Serial Ports:	2 x RJ45
Mains Input:	Filtered IEC, 110V-120V, or 220-240V switchable, fused, 9W maximum
Fuse Rating:	Anti-surge fuse 1A 20 x 5mm
<b>Equipment Type</b>	
RB-OA3:	3 Studio on-air switcher
<b>Physical Specification</b>	
Dimensions	48cm (W) x 15.8cm (D) x 4.2cm (H) (1U)
(Raw):	19" (W) x 6.2" (D) x 1.7" (H) (1U)
Dimensions (Boxed):	59cm (W) x 27.5cm (D*) x 11cm (H) 23.2" (W) x 10.8" (D*) x 4.3" (H)
Weight:	Nett: 1.9kg Gross: 2.5kg Nett: 4.2lbs Gross: 5.5lbs

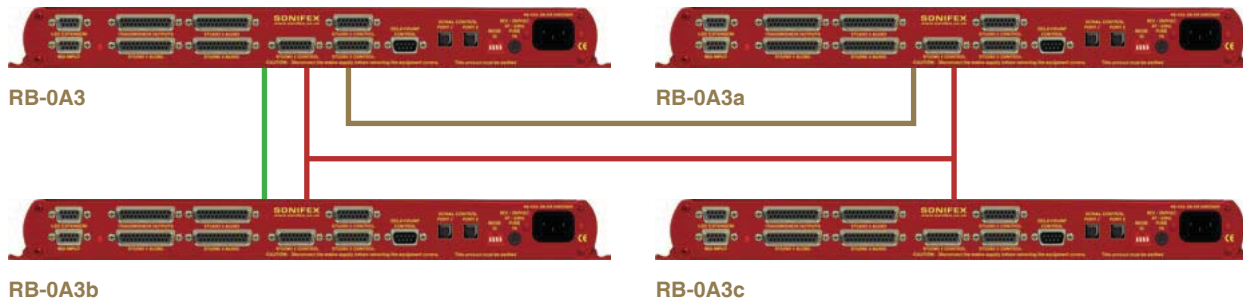

- Adding RB-OA3a allows 3 stereo channels to be switched between 5 studios.
- Adding RB-OA3b allows 6 stereo channels to be switched between 3 studios.
- Adding RB-OA3a , RB-OA3b and RB-OA3c allows 6 stereo channels to be switched between 5 studios.





## RB-OA3R Remote Switcher Panel For RB-OA3

The RB-OA3 has been designed for installation in a central technical area with cabling to custom panels, or selection switches, in each studio. If you don't have any custom switch panels available, you can use an RB-OA3R in each studio.

The RB-OA3R is a 1U rack mount switch unit for use in each studio that needs to be connected to the STUDIO 1-3 CONTROL connectors on an RB-OA3. It takes its power from the RB-OA3 unit so needs no power supply itself.

It contains four buttons which are used to control the functions of the RB-OA3. Each

front panel push button is illuminated by coloured LEDs and controls the OFFER, ACCEPT, DELAY and DUMP functions

### Specification For RB-OA3R

#### Audio Specification

#### Connections

Studio Control: 1 x 15 way D type plug (male)

#### Equipment Type

RB-OA3R: 1 Studio on-air switcher

#### Physical Specification

Dimensions 48cm (W) x 10.8cm (D) x 4.2cm (H) (1U)  
(Raw): 19" (W) x 4.3" (D) x 1.7" (H) (1U)

Dimensions 58.5cm (W) x 22.5cm (D) x 7cm (H)  
(Boxed): 23" (W) x 8.9" (D) x 2.8" (H)

Weight: Nett: 1.2kg Gross: 1.8kg  
Nett: 2.6lbs Gross: 4lbs



**Category:** Mixers, Source Selectors & Switchers.

**Product Function:** Remote switch panel for RB-OA3 unit.

#### Typical Applications:

Allows remote control of the RB-OA3 unit.

#### Features:

- Powered from the RB-OA3 unit.
- Allows the RB-OA3 unit to be situated in the main control room.
- Illumination of selected button showing status.

## RB-OA3C Expansion Unit Cable For RB-OA3

If you add another RB-OA3 to an existing unit to expand either the number of buses or studios, you need additional cables to connect it which are contained in this kit:

1 x Transmission output expansion cable, 25 pin D-type male to 25 pin D-type male, 30cm lead, wired pin to pin.

1 x LSO expansion cable, 9 pin D-type male to 9 pin D-type male, 30cm lead, wired pin to pin.

1 x RS232 expansion cable, RJ45 to RJ45 standard wiring, 30cm lead.

1 x kit should be used for each expansion RB-OA3 being used.





## RB-MA1 Single Microphone Amplifier



**Category:** Microphone Amplifiers & Limiters.

**Product Function:** Amplification of mic level signals to line level.

**Typical Applications:** To amplify additional microphones in a studio talks area, court room microphone amplification

**Features:**

- Neutrik XLR connectors.
- Mic input gain adjustment.
- +48V phantom power.
- High pass (rumble) filter.

The RB-MA1 consists of a low noise microphone pre-amplifier for converting mic level signals to line level, or for driving long lines from microphones to mixing equipment.

The connections and controls are on the rear panel. The microphone input is an XLR-3 type and is electronically balanced. The gain for the input can be adjusted by a recessed pre-set potentiometer which allows for the use of both dynamic and powered microphones.

The line output is of an XLR-3 type and is electronically balanced. It can be wired unbalanced by grounding the non-phase

signal, allowing you to feed both balanced and unbalanced equipment.

There is a switch to control a high pass filter (low frequency roll-off at 125Hz) and to provide phantom power at +48V to the connected microphone.

**Specification For RB-MA1**

Audio Specification	
Maximum Input Level:	-10dBu
Maximum Output Level:	+28dBu
Low Frequency Roll-Off:	125Hz @ 6dB/octave
E.I.N.:	130dB
Common Mode Rejection:	>60dB typically
Frequency Response:	20Hz to 20kHz ±0.1dB (600Ω load, ref 1kHz)
Input Impedance:	2kΩ nominal balanced

Output Impedance:	<50Ω
Gain Range:	Adjustable 36dB to 75dB gain
Distortion:	0.01% THD @ 1kHz, ref +8dBu output
Phantom Power:	48V
Connections	
Input:	1 x XLR 3 pin female (Balanced)
Output:	1 x XLR 3 pin male (Balanced, can be unbalanced)
Mains Input:	Filtered IEC, switchable 110-120V, or 220-240V, fused, 6W max
Fuse Rating:	Anti-surge fuse 100mA 20 x 5mm (230VAC) Anti-surge fuse 250mA 20 x 5mm (115VAC)
Equipment Type	
RB-MA1:	Single microphone amplifier
Physical Specification	
Dimensions (Raw):	28cm (W) x 10.8cm (D) x 4.2cm (H) (1U) 11" (W) x 4.3" (D) x 1.7" (H) (1U)
Dimensions (Boxed):	36cm (W) x 20.5cm (D) x 6cm (H) 14.2" (W) x 8" (D) x 2.4" (H)
Weight:	Nett: 0.90kg Gross: 1.35kg Nett: 2lbs Gross: 3lbs





## RB-MA2 Dual Microphone Amplifier



**Category:** Microphone Amplifiers & Limiters.

**Product Function:** Amplification of two mic level signals to line level.

**Typical Applications:** To amplify additional microphones in a studio talks area, court room microphone amplification, converting mic signal where mic and amp are a long distance apart.

**Features:**

- Neutrik XLR connectors.
- Mic input gain adjustment.
- +48V phantom power.
- High pass (rumble) filter.



The RB-MA2 consists of two independent low-noise microphone pre-amplifiers for converting mic level signals to line level, or for driving long lines from microphones to processing equipment.

All connections and controls are on the rear panel. The microphone inputs are XLR-3 type and are electronically balanced. The input gain for each input can be adjusted individually by a recessed pre-set potentiometer which allows for the use of both dynamic and powered microphones.

The XLR-3 line outputs are electronically balanced and can be wired unbalanced by grounding the non-phase signal, allowing you to feed both balanced and unbalanced equipment.

For each channel there are independent switches to control a high pass filter (low frequency roll-off at 125Hz) and to provide phantom power at +48V to the connected microphones.

### Specification For RB-MA2

**Audio Specification**

Maximum Input Level:	-10dBu
Maximum Output Level:	+28dBu
Low Frequency Roll-Off:	125Hz @ 6dB/octave
E.I.N.:	130dB
Common Mode Rejection:	>60dB typically
Frequency Response:	20Hz to 20kHz ±0.1dB (600Ω load, ref 1kHz)
Input Impedance:	2kΩ nominal balanced
Output Impedance:	<50Ω

Gain Range:	Adjustable 36dB to 75dB gain (each input)
Distortion:	0.01% THD @ 1kHz, ref +8dBu output
Phantom Power:	48V

**Connections**

Inputs:	2 x XLR 3 pin female (Balanced)
Outputs:	2 x XLR 3 pin male (Balanced, can be unbalanced)
Mains Input:	Filtered IEC, switchable 110-120V, or 220-240V, fused, 6W max
Fuse Rating:	Anti-surge fuse 100mA 20 x 5mm (230VAC) Anti-surge fuse 250mA 20 x 5mm (115VAC)

**Equipment Type**

RB-MA2:	Dual microphone amplifier
---------	---------------------------

**Physical Specification**

Dimensions (Raw):	28cm (W) x 10.8cm (D) x 4.2cm (H) (1U)
Dimensions (Boxed):	11" (W) x 4.3" (D) x 1.7" (H) (1U)
Weight RB-MA2:	Nett: 1.00kg Gross: 1.45kg Nett: 2.2lbs Gross: 3.2lbs



## RB-MA2G Dual Microphone Amplifier Gain Controls



**Category:** Microphone Amplifiers & Limiters.

**Product Function:** Amplification of two mic level signals to line level.

**Typical Applications:** To amplify additional microphones in a studio

talks area, court room microphone amplification, converting a mic to a line signal where mic and amp are a long distance apart.

**Features:**

- Front panel level adjustment.
- Front panel bright LED metering.
- Neutrik XLR connectors.
- Coarse mic input gain adjustment.
- +48V phantom power.
- High pass (rumble) filter.

The RB-MA2G consists of two independent low-noise microphone pre-amplifiers with front panel level controls and metering, for converting microphone level signals to line level, or for driving long lines from microphones to mixing equipment.

All connections are on the rear panel. The microphone input is XLR-3 type and is electronically balanced. The input gain can be adjusted individually by a recessed pre-set potentiometer. A front panel potentiometer gives ±12dB level adjustment and a 12 segment LED meter shows the audio level for each channel. The XLR-3 line output is electronically balanced and can be wired unbalanced by grounding the non-phase signal, allowing you to feed both balanced and unbalanced equipment.

For each channel there are independent switches to control a high pass filter (LF roll-off at 125Hz) and to provide phantom power at +48V to the connected microphone. An LED power indicator on the front panel displays the power supply connection.

### Specification For RB-MA2G

Audio Specifications	
Maximum Input Level:	+4dBu
Maximum Output Level:	+28dBu
Input Impedance:	2kΩ nominal balanced
Output Impedance:	<50Ω Balanced
Low Frequency Roll-Off:	125Hz @ 6dB/octave
Gain Range:	Adjustable 12dB to 80dB gain
E.I.N.:	-128dBu, 20kHz BW, max gain, Rs=200Ω
Distortion:	<0.01%, +8dBu, 20Hz – 20kHz, 40dB gain, 20kHz bandwidth
Common Mode Rejection:	>66dB @ 1kHz
Phantom Power:	48V
Frequency Response:	20Hz to 20kHz +0/-0.1dB
Connections	
Input:	2 x XLR 3 pin female (Balanced)
Output:	2 x XLR 3 pin male (Balanced, can be unbalanced)
Mains Input:	Filtered IEC, 110V-120V, or 220-240V switchable, fused, 9W maximum
Fuse Rating:	Anti-surge fuse 100mA 20 x 5mm (230VAC) Anti-surge fuse 250mA 20 x 5mm (115VAC)
Equipment Type	
RB-MA2G:	Dual microphone amplifier with gain
Physical Specifications	
Dimensions (Raw):	48cm (W) x 10.8cm (D) x 4.2cm (H) (1U)
Dimensions (Boxed):	58.5cm (W) x 22.5cm (D) x 7cm (H)
	23" (W) x 8.9" (D) x 2.8" (H)
Weight:	Nett: 1.35kg Gross: 2.0kg Nett: 3.0lbs Gross: 4.4lbs







## RB-DMA2 Dual Digital Microphone Amplifier



mic level signals to line level & AES/EBU outputs  
**Typical Applications:** To amplify additional microphones in a studio talks area, court room microphone amplification, converting mic signal where mic and amp are a long distance apart.  
**Features:** See RB-ADDA & RB-MA2.

**Category:** Microphone Amplifiers & Limiters.  
**Product Function:** Amplification of two

The RB-DMA2 consists of two independent low-noise microphone pre-amplifiers for converting microphone level signals to a digital AES/EBU or S/PDIF output. Individual analogue balanced line level outputs are also produced for use, for example, to feed talkback systems. The unit can either be used as two independent microphone amplifiers, or one mic input can be copied to both channels of the digital output.





The microphone inputs are XLR-3 type and are electronically balanced. The input gain for each input can be adjusted individually by a volume control on the front panel enabling the use of dynamic and powered microphones and each has a LED level indicator. For each channel there are independent switches to control a high pass filter (low frequency roll-off at 125Hz) and to provide phantom power at +48V to the connected microphones.

The RB-DMA2 has AES/EBU, S/PDIF and TTL word clock sync inputs and has the same sync modes, bit depth selection, channel status bit adjustment, front panel LED synchronisation and calibration routine as the RB-ADDA. Please refer to that product for further information.

### Specification For RB-DMA2

#### Audio Specification

Input Level:	Max -25dBu, Min -62dBu to give FSD
Input Impedance:	2kΩ nominal
Input Gain Range:	37dB
Low Frequency Roll-off:	125Hz @ 6dB/octave
Signal To Noise:	130dB EIN
Dynamic Range:	>110dB
Distortion And Noise:	<0.01% THD + N absolute @ 1kHz
Phantom Power:	48V

#### Connections

Microphone Inputs:	2 x XLR 3 pin female (balanced)
Sync Inputs:	1 x AES/EBU XLR 3 pin female (balanced) 1 x S/PDIF RCA phono socket, 1 x TTL BNC female

Analogue Outputs:	2 x XLR 3 pin male (balanced)
Digital Outputs:	1 x AES/EBU XLR 3 pin male (balanced), 1 x S/PDIF RCA phono socket
Mains Input:	Filtered IEC, switchable 110-120V, or 220-240V, fused, 10W max
Fuse Rating:	Anti-surge fuse 100mA 20 x 5mm (230VAC) Anti-surge fuse 250mA 20 x 5mm (115VAC)

#### Equipment Type

RB-DMA2:	Dual digital microphone amplifier
----------	-----------------------------------

#### Physical Specification

Dimensions (Raw):	48cm (W) x 10.8cm (D) x 4.2cm (H) (1U) 19" (W) x 4.3" (D) x 1.7" (H) (1U)
Dimensions (Boxed):	58.5cm (W) x 22.5cm (D) x 7cm (H) 23" (W) x 8.9" (D) x 2.8" (H)
Weight:	Nett: 1.6kg    Gross: 2.2kg Nett: 3.5lbs    Gross: 4.8lbs



## RB-ML2 Stereo Microphone & Line Level Limiter



**Category:** Microphone Amplifiers & Limiters.

**Product Function:** To limit the maximum output level for 2 x mic/line audio signals.

**Typical Applications:** To protect mixer inputs, for mic inputs to a PC workstation, to amplify additional microphones in a studio talks area.

**Features:**

- Mic/line input & mic/line output levels.
- Mic input gain adjustment.
- +48V phantom power.
- High pass (rumble) filter.

The RB-ML2 is a stereo microphone and line level limiter. The unit is mainly used where assistance with level control is required, for protection of mixer inputs and to prevent distortion. Ideal for news-booths, and the input to PC workstations, it provides an economical level control solution.

The RB-ML2 has two electronically balanced XLR-3 inputs, which are routed to a line amplifier, or microphone amplifier, via a rear push-button. The microphone amplifiers have independent pre-set gain controls, and DIP switches for a high pass filter (low frequency roll-off at 125kHz) and phantom power to provide +48V to the connected microphones.

The outputs of these amplifiers are passed through a VCA limiter circuit that can operate jointly on the signals in stereo mode, or independently in dual mono mode. The

rear panel mode switch changes the unit from dual mono to stereo. Stereo limiting operates by limiting both left and right outputs if either left or right input needs to be limited. Dual mono limiting operates by limiting left and right signals individually, so you can use the RB-ML2 as two separate mono mic/line limiters.

The characteristics of the limiter can be set via level threshold pre-sets. For each channel there is an input gain and a threshold level control. With the limit threshold set to maximum, the input through to output can be normalised using the input potentiometers. Once the unit is acting as a buffer with gain/attenuation, the limit threshold level can be set, with the recovery adjusted for the application. The power LED indicates limiting by flashing.

The two XLR-3 electronically balanced outputs can be set to either line or mic output levels via a push-button. This allows the RB-ML2 to be used in line with a line or mic input on a mixer, or similar equipment.

### Specification For RB-ML2

#### Audio Specification

Maximum Input Level:	-6dBu (mic), +28dBu (line), electronically balanced
----------------------	---

Input Impedance:	>20kΩ balanced bridging
Input Gain Range:	Adjustable +22dB to +67dB gain (mic) via 2 x pre-set potentiometers (L & R), 0dB gain (line)
Maximum Output Level:	-18dBu (mic), +28dBu (line), electronically balanced
Output Impedance:	<50Ω balanced
Output Gain Range:	Adjustable -54dB to -24dB gain (mic), -8dB to +22dB gain (line), ref 0dBu line input, gain via 2 x pre-set pots
Limit Threshold:	Adjustable -8dBu to +28dBu
Frequency Response:	20Hz to 20kHz ±0.1dB (600Ω load, ref 1kHz)
Noise (RMS):	< -70dB unity gain, ref +8dBu output
Distortion:	< 0.02% THD + N @ 1kHz, ref +8dBu output, threshold set at +10dBu
Common Mode Rejection (Line):	>66dB typically
Common Mode Rejection (Mic):	>86dB typically
Phantom Power:	+48V
LF Filter:	125Hz @ 6dB/octave
<b>Connections &amp; Controls</b>	
Analogue Inputs:	2 x XLR 3 pin female mic or line switchable (balanced) (L & R)
Mic/Line Control:	2 x push-buttons for mic/line inputs
Analogue Outputs:	2 x XLR 3 pin male mic or line switchable (balanced) (L & R)
Mains Input:	Filtered IEC, switchable 110-120V, or 220-240V, fused, 6W max.
Fuse Rating:	Anti-surge fuse 100mA 20 x 5mm (230VAC) Anti-surge fuse 250mA 20 x 5mm (115VAC)
Mic/Line Output Control:	2 x push-button for mic/line outputs
Phantom Power & LF Filter:	1 x 4-way DIP switch
Mono/Stereo Mode Select:	1 x push-button
Limit Level Threshold Set:	2 x pre-set potentiometers
<b>Equipment Type</b>	
RB-ML2:	Stereo microphone limiter
<b>Physical Specification</b>	
Dimensions (Raw):	28cm (W) x 10.8cm (D) x 4.2cm (H) (1U) 11" (W) x 4.3" (D) x 1.7" (H) (1U)
Dimensions (Boxed):	36cm (W) x 20.5cm (D) x 6cm (H) 14.2" (W) x 8" (D) x 2.4" (H)
Weight:	Nett: 0.90kg Gross: 1.35kg Nett: 2lbs Gross: 3lbs





## RB-SL2 Twin Mono, Or Stereo, Limiter



**Category:** Microphone Amplifiers & Limiters.

**Product Function:** To limit the maximum output level for a stereo or twin mono line level audio signal.

**Typical Applications:** Limiting program output from a radio studio mixer, school radio audio output limiter.

**Features:**

- Stereo or mono operation, can be used as two mono limiters.
- Input gain & threshold limit controls.

The RB-SL2 is a stereo, or twin independent mono, VCA limiter for use in news-rooms and other locations where the correct level into recording equipment is required, but not necessarily under the control of an engineer, for example, for overload protection.

It can also be used as an inexpensive main output limiter for small scale radio stations, hospital radio and student radio.

The XLR-3 electronically balanced inputs and outputs can be wired unbalanced to accept an output from domestic equipment.

For each channel there is an input gain and a threshold level control. With the limit threshold set to maximum, the input through to output can be normalised using

the input potentiometers. Once the unit is acting as a buffer with gain/attenuation, the limit threshold level can be set, with the recovery adjusted for the application. The power LED indicates limiting by flashing.

The rear panel mode switch changes the unit from dual mono to stereo, when only the pre-sets for channel 1 (left) are active and apply to both channels. Stereo limiting operates by limiting both left and right outputs if either left or right input needs to be limited. Dual mono limiting operates by limiting left and right signals individually, so you can use the RB-SL2 as two separate mono limiters.

### Specification For RB-SL2

#### Audio Specification

Maximum Input Level:	+28dBu
Maximum Output Level:	+28dBu
Input Gain:	Adjustable -8dB to +18dB gain
Limit Threshold:	Adjustable -8dBu to +28dBu
Frequency Response:	20Hz to 20kHz $\pm 0.1$ dB (600 $\Omega$ load, ref 1kHz)
Noise:	-100dB unity gain, ref +8dBu output
Distortion:	0.01% THD @ 1kHz, ref +8dBu output, threshold set at +10dBu
Common Mode Rejection:	>66dB typically
Input impedance:	>20k $\Omega$ balanced bridging
Output impedance:	<50 $\Omega$ balanced
<b>Connections</b>	
Inputs:	2 x XLR 3 pin female (Balanced, can be unbalanced)
Outputs:	2 x XLR 3 pin male (Balanced, can be unbalanced)
Mains Input:	Filtered IEC, switchable 110-120V, or 220-240V, fused, 6W max
Fuse Rating:	Anti-surge fuse 100mA 20 x 5mm (230VAC) Anti-surge fuse 250mA 20 x 5mm (115VAC)

#### Equipment Type

RB-SL2: Twin mono, or stereo, limiter

#### Physical Specification

Dimensions (Raw):	28cm (W) x 10.8cm (D) x 4.2cm (H) (1U) 11" (W) x 4.3" (D) x 1.7" (H) (1U)
Dimensions (Boxed):	36cm (W) x 20.5cm (D) x 6cm (H) 14.2" (W) x 8" (D) x 2.4" (H)
Weight:	Nett: 1.0kg Gross: 1.45kg Nett: 2.2lbs Gross: 3.2lbs





## RB-SM1 Single Stereo To Mono Converter



**Category:** Stereo to Mono Converters.

**Product Function:** To create a mono output from a stereo source.

**Typical Applications:** To supply cue in broadcast environments, to make a mono feed for AM transmission, or to feed a mono PA system.

**Features:**

- Neutrik XLR connectors.
- Balanced audio but can be wired unbalanced.
- Output gain adjustment.

The RB-SM1 converts a stereo input to a fully buffered and balanced mono line output, e.g. to supply cue in broadcast environments or to feed a mono PA system.

The connections, which are on the rear panel, are of an XLR-3 type. The input is electronically balanced with an impedance of 20kΩ bridging. This can be wired unbalanced to accept an output from domestic equipment.

The output is electronically balanced with an output impedance of <50Ω. The output can be wired unbalanced by grounding the non-phase signal, allowing you to feed both balanced and unbalanced equipment.

Output gain adjustment using a pre-set potentiometer for the converter allows a normalised mono output from domestic stereo equipment. This potentiometer is accessible through the rear panel.

### Specification For RB-SM1

**Audio Specification**

Maximum Input Level:	+28dBu
Maximum Output Level:	+28dBu
Input Impedance:	>20kΩ balanced bridging
Output Impedance:	<50Ω balanced
Frequency Response:	20Hz to 20kHz ±0.1dB (600Ω load, ref 1kHz)
Gain Range:	Adjust -8dB to +18dB gain, ref. 0dB input on L and R
Common Mode Rejection:	>66dB typically

Distortion:	0.01% THD @ 1kHz, ref +8dBu output
Noise:	-100dB, unity gain, ref +8dBu output
<b>Connections</b>	
Inputs:	2 x XLR 3 pin female (Balanced, can be unbalanced)
Output:	1 x XLR 3 pin male (Balanced, can be unbalanced)
Mains Input:	Filtered IEC, switchable 110-120V, or 220-240V, fused, 6W max
Fuse Rating:	Anti-surge fuse 100mA 20 x 5mm (230VAC) Anti-surge fuse 250mA 20 x 5mm (115VAC)
<b>Equipment Type</b>	
RB-SM1:	Single stereo to mono converter
<b>Physical Specification</b>	
Dimensions (Raw):	28cm (W) x 10.8cm (D) x 4.2cm (H) (1U) 11" (W) x 4.3" (D) x 1.7" (H) (1U)
Dimensions (Boxed):	36cm (W) x 20.5cm (D) x 6cm (H) 14.2" (W) x 8" (D) x 2.4" (H)
Weight:	Nett: 1.00kg Gross: 1.45kg Nett: 2.2lbs Gross: 3.2lbs



## RB-SM2 Dual Stereo To Mono Converter



**Category:** Stereo to Mono Converters.

**Product Function:** To create two mono outputs from two stereo sources.

**Typical Applications:** To supply cue in broadcast environments, to make a mono feed for AM transmission, or to feed a mono PA system.

**Features:**

- Neutrik XLR connectors.
- Balanced audio but can be wired unbalanced.
- Output gain adjustment.

The RB-SM2 is a dual version of the RB-SM1, consisting of two independent converters which will produce two fully buffered and balanced mono line outputs from two stereo inputs.

All connections are on the rear panel. The XLR-3 inputs are electronically balanced with an impedance of 20kΩ bridging. These can be wired unbalanced to accept an output from domestic equipment.

The XLR-3 line outputs are electronically balanced with an output impedance of <50Ω. The outputs can be wired unbalanced

by grounding the non-phase signal, allowing you to feed both balanced and unbalanced equipment.

Output gain adjustment using pre-set potentiometers for both converters allows a normalised mono output from domestic stereo equipment. The potentiometers are accessible through the rear panel.

### Specification For RB-SM2

Audio Specification	
Maximum Input Level:	+28dBu
Maximum Output Level:	+28dBu
Input Impedance:	>20kΩ balanced bridging
Output Impedance:	<50Ω balanced
Frequency Response:	20Hz to 20kHz ±0.1dB (600Ω load, ref 1kHz)

Gain Range:	Adjust -8dB to +18dB gain, ref. 0dB input on L and R
Common Mode Rejection:	>66dB typically
Distortion:	0.01% THD @ 1kHz, ref +8dBu output
Noise:	-100dB, unity gain, ref +8dBu output

Connections	
Inputs:	4 x XLR 3 pin female (Balanced, can be unbalanced)
Outputs:	2 x XLR 3 pin male (Balanced, can be unbalanced)
Mains Input:	Filtered IEC, switchable 110-120V, or 220-240V, fused, 6W max
Fuse Rating:	Anti-surge fuse 100mA 20 x 5mm (230VAC) Anti-surge fuse 250mA 20 x 5mm (115VAC)

Equipment Type	
RB-SM2:	Dual stereo to mono converter
Physical Specification	
Dimensions (Raw):	28cm (W) x 10.8cm (D) x 4.2cm (H) (1U) 11" (W) x 4.3" (D) x 1.7" (H) (1U)
Dimensions (Boxed):	36cm (W) x 20.5cm (D) x 6cm (H) 14.2" (W) x 8" (D) x 2.4" (H)
Weight:	Nett: 1.05kg Gross: 1.50kg Nett: 2.3lbs Gross: 3.3lbs







## RB-LC3 3 Way Light/Power Controller



**Category:** Power Controllers.

**Product Function:** To switch mains power to 3 x IEC outlets for mains voltage signal lamps.

**Typical Applications:** Controlling radio studio On-Air, Mic-Live and Telephone signal lamps.

**Features:**

- GPI to control switching of 3 IEC outlets.
- Telephony input for 'Call Ringing' displays.
- Flash rate control.

The RB-LC3 is a triple output switching unit for controlling external mains indicators, primarily studio status lights for broadcasting applications, such as On-Air, Mic-Live and Rehearsal/Live lights.

Each output can be individually controlled by one of three remote inputs (pulled high,

or low), by a telephony input (when ringing, or off-hook, or both), or a combination of two inputs (to control two outputs, e.g. for Rehearsal/Live situations). The type of control is set using the 12 way DIP switch (4 switches for each output, allowing 16 different settings).

All connections are on the rear panel. The three IEC outputs are controlled by zero-cross point drivers. When an output is activated, the A.C. voltage level at that output will be equal to the mains input voltage used to power the unit.

External control of the switched mains outputs is via the 15 way D-type plug connector.

The telephone line input and handset output are via two RJ11-4 type connectors. The telephone connections are wired pin to pin from line to handset except when the remote 'Ring Mute' control input is asserted. In this case the ring signal to the handset is muted.

The status of the telephone line is continually monitored so that handset

ringing and off-hook conditions can be indicated.

A pre-set potentiometer on the rear panel controls the flash rate of the output when the appropriate mode is selected. Neon indicators on each power socket show the status of the mains output.

### Specification For RB-LC3

**Audio Specification**

Connections	
Mains Input:	Non-filtered IEC, 110V-240V auto-adjusting, fused, 6W maximum
Mains Outputs:	3 x Non-filtered IEC plugs, 1A fused
Fuse Rating (Mains Outputs):	3 x Anti-surge fuse 1A 20 x 5mm
Telephone:	2 x RJ11-4 sockets
Control Inputs & Outputs:	15 way D-type plug Inputs: 0V- 5V DC Outputs: Open collector 20mA sink capability

**Equipment Type**

RB-LC3:	3 way light/power controller
---------	------------------------------

**Physical Specification**

Dimensions	28cm (W) x 10.8cm (D) x 4.2cm (H) (1U)
(Raw):	11" (W) x 4.3" (D) x 1.7" (H) (1U)
Dimensions (Boxed):	36cm (W) x 20.5cm (D) x 6cm (H) 14.2" (W) x 8" (D) x 2.4" (H)
Weight:	Nett: 1.00kg Gross: 1.45kg Nett: 2.2lbs Gross: 3.2lbs





## RB-MM1 Mix-Minus Generator



**Category:** Talkback & Communications.

**Product Function:** To generate a suitable mix to send to a telephone hybrid or codec from a mixer.

**Typical Applications:** Used with mixers without mix-minus busses.

**Features:**

- Neutrik input and output connectors.
- Output level adjustment.
- Cancellation null adjustment.
- Band pass filter.

Whenever programming originates from outside of the studio, or if listeners/viewers are calling a phone-in using telephone hybrids or codecs, mix-minus feeds are required. Most telephone lines incur delays which prohibit off-air monitoring, because the caller, or remote talent, would hear their own voice in delay which is very disconcerting. The solution is to feed a mix back to the caller minus his or her own voice. Some mixing desks do not have a dedicated telco channel to generate a clean-feed, or mix minus, so the RB-MM1 can be used.

The RB-MM1 is a unit for generating a suitable mix to send to a telephone hybrid or codec. A stereo output is taken from a mixer, together with a post fader output

from the mono telephone fader on the mixer. The caller audio is removed from the station output so that it can be sent to the telephone line via the hybrid.

Analogue audio inputs and outputs are via Neutrik XLR connectors. The output level to the TBU can be adjusted using a rear panel pre-set potentiometer. To control the cancellation null (the amount of the telephone channel which is subtracted from the mixer output signal), 2 multi-turn potentiometers are provided, one for the LF null and the other for the full-band null. Additionally, a band pass filter can be switched in and out, via a rear panel switch, to condition the signal for the telephone hybrid. To use the RB-MM1 unit with full-band ISDN codecs, the band pass filter can be switched out. For stereo codecs, or conference calls, multiple RB-MM1 units can be used.

### Specification For RB-MM1

#### Audio Specification

Maximum Input Level:	+28dBu
Input Impedance:	>20kΩ
Maximum Output Level:	+28dBu
Output Impedance:	<50Ω
Output Gain Range:	Adjustable -15dB to +12dB, ref 0dBu gain via a multi-turn pot
Common Mode Rejection:	>60dB
Band Pass Filter Range:	200Hz to 4kHz, 12dB/octave
LF Null Adjustment:	Better than 40dB at 100Hz
Mix-Minus Null:	Better than 40dB at 1kHz
Frequency Response:	20Hz - 22kHz ± 0.1dB
Distortion:	0.01% THD @ 1kHz, ref +8dBu output (C-Message weighted)
Noise:	-90dBu unity gain +6dBu

#### Connections

Analogue Inputs From Mixer Output:	2 x XLR 3 pin female (balanced) (L & R)
Analogue Input From Telephone Fader:	1 x XLR 3 pin female (balanced) (L & R)
Analogue Output To TBU:	1 x XLR 3 pin male (balanced) (L & R)
Mains Input:	Filtered IEC, switchable 110-120V, or 220-240V, fused, 6W max.
Fuse Rating:	Anti-surge fuse 100mA 20 x 5mm (230VAC) Anti-surge fuse 250mA 20 x 5mm (115VAC)

#### Equipment Type

RB-MM1: Mix-minus generator

#### Physical Specification

Dimensions (Raw):	28cm (W) x 10.8cm (D) x 4.3cm (H) 11" (W) x 4.3" (D) x 1.7" (H)
Dimensions (Boxed):	36cm (W) x 20.5cm (D) x 6cm (H) 14.2" (W) x 8" (D) x 2.4" (H)
Weight:	Nett: 1.1kg Gross: 1.5kg Nett: 2.4lbs Gross: 3.3lbs





## RB-MTV1 Contribution Voiceover Monitor With Talkback



**Category:** Talkback & Communications.

**Product Function:** Mixes a mic, talkback and two stereo inputs to headphone output and two line outputs.

**Typical Applications:** In voice-over booths, news booths, commentary locations, for continuity announcements and for any other similar applications where voice needs to be added to programme content and then monitored, with talkback.

### Features:

- Wide mic input gain range.
- High pass filter & +48V phantom power.
- Switchable level limiter with threshold control.
- Mic level metering.
- 'Lazy' talkback input/output & button.
- Two stereo inputs, which can be balanced or unbalanced (+10dB pad).
- Front panel headphone output with a volume control for each input.
- Headphone monitoring configured via DIPswitches.
- Two mic/line outputs.
- Remote control of MIC and TALK buttons.

The RB-MTV1 contribution voiceover monitor is a 1U rack-mount designed to be used in voice-over booths, news booths, commentary locations, for continuity announcements and for any other similar applications where voice needs to be added to programme content and then monitored. Programme feeds, auxiliary feeds and a talkback feed can be taken and monitored.

The RB-MTV1 has four inputs and two outputs. It has a mono microphone input on XLR with switched coarse gain and variable fine gain control using a multi-turn preset potentiometer to give an overall gain range from +20dB to +80dB. There is also a switched LF rumble filter, switched +48V phantom power and switched level limiting control.

A rear-panel multi-turn preset potentiometer allows adjustment of the threshold at which the limiter begins to operate, from -8dBu to +26dBu. There is an indication of the limiter activity using a blue LED and the microphone level is monitored by a simple 5 LED meter. The meter can be configured to either show the MIC signal activity in normal operation, i.e. when TALK is pressed the meter is off, or the meters can permanently show the MIC activity even when the TALK button is on or the MIC button is off.

There is a mono balanced TALKBACK input on XLR. There are two balanced XLR stereo inputs, CUE and programme (PGM) each with a 10dB input gain switch to facilitate the use of unbalanced sources such as from PC audio cards, domestic CD players, etc.

Each of these inputs, MIC, TALKBACK, CUE and PGM can be mixed and monitored in the front and rear headphone outputs

with individual volume controls. Which of the inputs is presented to the headphone outputs can be configured using two banks of DIPswitches on the underside of the unit, one bank for audio that is heard in the left ear piece and one bank for audio monitored in the right ear piece. For example, the left and right PGM inputs can be sent to the right ear-piece and all other signals to the left ear-piece, or the TALK signal could be sent to the right ear-piece and all other signals to both ear-pieces. In this way, you can configure the unit for your particular application on installation. If a presenter doesn't like to hear themselves in their headphones when using the TALK button, there is also a DIPswitch option to mute the mic signal to the headphones.

There are two mono balanced outputs. The processed microphone signal is fed to the two outputs when the latching front panel MIC button is active - the button illuminates when active.

The two main outputs can be independently switched to be at 'Line' or 'Mic' level outputs using rear panel push switches. Setting the output to a microphone level allows the unit to be inserted into the microphone channel of a mixer.

There is an option to permanently enable the MIC button, even when remotely controlled, for occasions when you always want the MIC channel left open. Additionally, there is an option to mix the CUE input as a mono feed to the outputs permanently.

The front panel TALK button is a momentary push switch that routes the processed microphone signal to the "LAZY" TALK output, whilst disconnecting it from the main outputs, allowing the operator to talk to a colleague. This enables the unit to be used as a talkback intercom between two or more studios.

There is a rear panel remotes connector giving remote control of the two front panel MIC and TALK buttons and opto-isolated tallies of their status.

A red LED on the front panel of the unit indicates when power is present.

**Specification For RB-MTV1**

Audio Specification	
Input Impedance:	2kΩ nominal balanced MIC input >20kΩ all other inputs.
Maximum Input Level:	-10dBu MIC input +26dBu TALK, CUE & PGM inputs
Mic Gain Range:	Adjustable +20dB to +80dB
E.I.N.:	130dB
Common Mode Rejection:	>60dB typically
Low Frequency Roll-Off:	125Hz @ 6dB/octave
Distortion:	0.01% THD @ 1kHz, ref +8dBu o/p
Phantom Power:	48V
Limiter Threshold:	Adjustable +8dBu to +28dBu
Output Impedance:	<50Ω
Maximum Output Level:	+26dBu balanced outputs
Headphone Output Level:	Drives 150mW into 32Ω to 600Ω headphones
Frequency Response:	20Hz to 20KHz ±0.1dB (ref 1KHz)
Rear Panel Connections	
Mic Input:	1 x XLR 3 pin female (Balanced)
TALKBACK Input:	1 x XLR 3 pin female (Balanced)
CUE Inputs:	2 x XLR 3 pin female (Balanced)
PGM Inputs:	2 x XLR 3 pin female (Balanced)
Output 1:	1 x XLR 3 pin male (Balanced)
Output 2:	1 x XLR 3 pin male (Balanced)
TALK (LAZY) Output:	1 x XLR 3 pin male (Balanced)
Headphone Outputs:	2 x ¼" (6.35mm) A-gauge 3-pole stereo jack sockets
Remote I/O Port:	9-way 'D'-type socket
Mains Input:	Filtered IEC, 110V-120V, or 220-240V switchable, fused, 9W max
Fuse Rating:	Anti-surge fuse 100mA 20 x 5mm (230VAC) Anti-surge fuse 250mA 20 x 5mm (115VAC)
Equipment Type	
RB-MTV1:	Contribution voiceover unit with talkback
Physical Specification	
Dimensions (H) (Raw):	48cm (W) x 10.8cm (D) x 4.3cm (H) (1U)
Dimensions (Boxed):	58.5cm (W) x 22.5cm (D) x 7cm (H) (23" (W) x 8.9" (D) x 2.8" (H))
Weight :	Nett: 1.3kg    Gross: 1.9kg Nett: 2.9lbs    Gross: 4.2lbs
Accessories	
RB-RK3:	1U Rear panel rack kit for large Redboxes

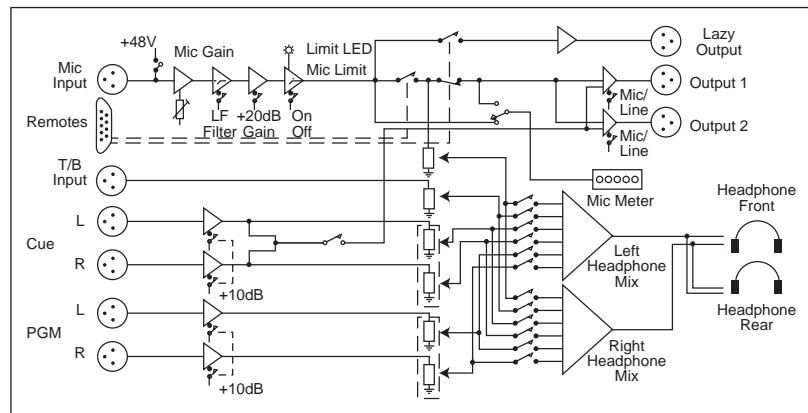

RB-MTV1 Block Diagram.





## RB-IPE IP Extender for GPIO & Analogue Control Signals



**Category:** Talkback & Communications.

**Product Function:** Provides remote control and telemetry of GPIO and analogue control voltages over an Ethernet network.

**Typical Applications:** It allows any

tallies & control signals, together with analogue potentiometer movements, to be sent across a network, e.g. for remote alarm points, to trigger failure alarms at transmitter sites and to control remote equipment at unmanned posts, outstations or transmitter sites.

**Features:**

- 8 x isolated current sink inputs.
- 8 x pull to ground protected inputs.

- 8 x isolated relay change-over output contacts.
- 8 x opto-isolated output contacts.
- 8 x 0 to 3.3V/5V/12V input signals.
- 8 output signals nominally at 0 to 3.3V.
- Two units can act as master and slave.
- Input & output voltages can be mapped.
- Webserver configuration and control.

The RB-IPE is a 1U rackmount unit designed to provide remote control of GPIO and analogue control voltages over an Ethernet network. Configured using a built-in web server, two units can control each other across an Ethernet network, or a single unit can be controlled via Ethernet commands and the web server interface.

The unit can be used in any position where you need to remotely acquire GPO signals or remotely control equipment, for example controlling equipment at unmanned posts, outstations or transmitter sites.

Each unit has 16 x general purpose inputs on 8 x RJ45 connectors, consisting of 8 x isolated current sink inputs and 8 x pull to ground





protected inputs; and 16 x general purpose outputs on 8 x RJ45 connectors using 8 x isolated relay change-over contacts and 8 x opto-isolated contacts. These rear panel RJ45 connectors have an LED for each GPIO which shows its state.

On another 8 x RJ45 connectors there are also 8 x 0 to 3.3V/5V/12V input signals and 8 output signals nominally at 0 to 3.3V output, with other output voltage configurations possible. The outputs can all be controlled from the inputs of another RB-IPE, or from Ethernet commands.

This allows any tallies and control signals, together with analogue potentiometer movements, to be sent across a network, e.g. for remote alarm points, to trigger failure alarms at a transmitter site and to control remote equipment.

When two units are connected together at different sites, if a general purpose input state changes at one site the unit sends the new state to the other site and the appropriate opto-isolator output changes on that unit. Similarly input voltage controls are monitored and the changing voltage is sent to the remote unit where an output voltage changes accordingly.

The signals can be routed and distributed such that a single input signal to a unit on

one site can be routed to multiple outputs in a unit on another site and/or have the logic inverted and distributed to multiple outputs. Also, the state of the GPOs when the unit is powered on can be configured, allowing more reliable recovery of external connected equipment from a power-fail condition.

The analogue I/O control signals can be mapped to give different ranges between the incoming and outgoing signal, e.g. 0V to 5V input giving a 0V to 12V output, or a linear input mapped to a log scale output. Also, by programming threshold values, analogue input voltages can be mapped to GPO pins, e.g. for sending a signal to a GPO when a volume knob is turned too high.

The web server in the RB-IPE can be configured with a static IP address or by using DHCP.

The three front panel green LEDs give an indication of Ethernet connectivity, i.e. they show when commands are being sent/received. The CONNECTED LED shows link status, the GPIO LED illuminates whenever a GPIO state changes and the ANALOGUE LED indicates a change in state of the analogue voltage signals.

The RB-IPE is powered from a universal mains input between 85-264V AC at 47-63Hz.

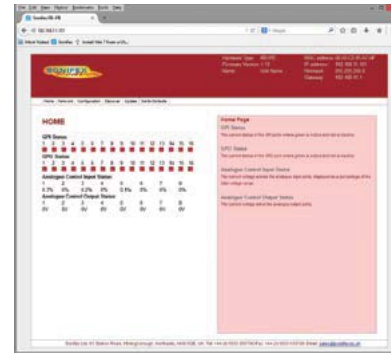

RB-IPE Home Page.

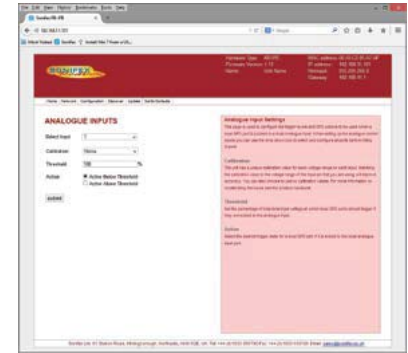

RB-IPE Configuration of Analogue Inputs Page.

### Specification For RB-IPE

#### Audio Specification

#### Rear Panel Connections

Isolated GPI:	4 x RJ45 sockets, with LED status indicator per input
Active Low GPI:	4 x RJ45 sockets, with LED status indicator per input
Relay GPO:	4 x RJ45 sockets, with LED status indicator per output
Isolated GPO:	4 x RJ45 sockets, with LED status indicator per output
Analogue Control Inputs:	4 x RJ45 sockets
Analogue Control Outputs:	4 x RJ45 sockets
Ethernet Port:	RJ45 with status LEDs
Mains Input:	Filtered IEC, continuously rated 85-264VAC @ 47-63Hz, 10W max
Fuse Rating:	Anti-surge fuse 1A 20 x 5mm

#### Input & Output Detail

General Purpose Inputs:	8 x isolated current sink inputs from 3.3V to +24V (Max input range: 0V to +24V) 8 x pull to ground protected inputs (Max input range -24V to +24V)
General Purpose Outputs:	8 x isolated relay change-over contacts: Nominal switching capacity (resistive load): 1A @ 30V DC (0.5A @ 125V AC) 8 x opto-isolated contacts:

Maximum collector/emitter voltage peak: 35V DC @ 7mA  
Maximum collector/emitter current: 80mA @ 2.5V DC  
(Note: There is a 200 mA fused +5V power supply available on GPI ports 1 – 8 and GPO ports 9 – 16.)

Analogue Control Inputs:	8 x 0V-3.3V, 5V or 12V input signals
Analogue Control Outputs:	8 x output signals, nominally 0V-3.3V, 5V or 12V

#### Front Panel Indicators

Power On:	Red LED
CONNECTED:	Green link status LED
GPI:	Green GPIO change status LED
ANALOGUE:	Green analogue control I/O change status LED

#### Equipment Type

RB-IPE:	IP extender for GPIO & analogue control signals
---------	---

#### Physical Specification

Dimensions (Raw):	48cm (W) x 10.8cm (D) x 4.2cm (H) (1U) 19" (W) x 4.3" (D) x 1.7" (H) (1U)
Dimensions (Boxed):	58.5cm (W) x 22.5cm (D) x 7cm (H) 23" (W) x 8.9" (D) x 2.75" (H)
Weight:	Nett: 1.6kg Gross: 2.2kg Nett: 3.5lbs Gross: 4.8lbs

#### Accessories

RB-RK3	1U Rear panel rack kit for large Redboxes
--------	---



## RB-TGHD(B or X) Multi-Channel HD Tone Generator



**Category:** Tone Generators.

**Product Function:** 8 Channel audio tone generator that provides line identification for multi-channel audio systems.

**Typical Applications:** It allows correct channel configuration in fold-down mixes when you need to mix several audio channels into a stereo feed, e.g. 5.1 and 7.1 surround sound.

**Features:**

- 8 analogue & 8 digital output channels.
- EBU R49, GLITS and BLITS tones, with channel identification.

- 2, 4, 6 and 8 channel configurations.
- Wordclock sync input.
- Optional sync boards available.
- Audio level line-up adjustable from 0dBu to +24dBu.
- Available with BNC (B) or XLR (X) digital audio outputs.
- Programmable audio tone sequences using SCI serial remote.

The RB-TGHD is an 8 channel audio tone generator that provides line identification for multi-channel audio systems, including 5.1 and 7.1 surround sound typically used in high definition television broadcasts. By using a range of widely accepted industry standard tone sequences such as the EBU R49, GLITS and BLITS tones, channel identification and associated levels can be determined easily.

Correct channel configuration in fold-down mixes can also be highlighted when a broadcaster needs to mix several audio channels into a stereo feed.



RB-TGHD Multi-Channel HD Tone Generator.



sci **RK3** **24** BIT  
**192** kS/s

RB-TGHDX Multi-Channel High Definition Tone Generator.

The RB-TGHDX caters for 2, 4, 6 and 8 channel configurations and all of the available audio tone sequences for each channel configuration can be cycled through automatically, or selected manually, and a loop mode allows patterns of tones to be repeated. A bank of 4 pushbuttons on the front panel sets these options and the associated LEDs indicate the current setting. A set of 8 LEDs on the front panel indicate

which channel is currently outputting audio with the LEDs numbered as both 1-8 and as L, R, C, LFE, LS, RS, LR and RR.

The RB-TGHDX is available in two variations, each providing both analogue and digital audio outputs. The RB-TGHDX offers balanced AES/EBU digital audio outputs on 3 pin XLR connectors and the RB-TGHDB has unbalanced digital audio outputs on BNC

connectors. Both types provide 8 balanced analogue outputs on 3 pin XLR connectors.

A word clock synchronising input on BNC connector allows the digital outputs to be synchronised to an external signal. Optionally, an RB-SYA, RB-SYD or RB-SYE sync board can be fitted, to synchronise the unit to either an analogue or digital video sync signal, or an AES/EBU audio input

respectively. A SYNC LED on the front panel indicates when the unit is synchronised to the external signal.

The audio level line-up of the RB-TGHDX can be adjusted from 0dBu to +24dBu in 1dBu steps (ref FSD) to suit different environments via the front panel mounted DIPswitches. Changing the audio line-up does not affect the gain relationship

between each channel, ensuring that correct levels through the target system can be maintained. These switches also provide settings for digital sample rate which ranges from 32 kHz to 192 kHz, and digital sample width which is either 16 bit or 24 bit.

The serial port allows the RB-TGHD to be connected to a PC running SCI, the Sonifex Serial Control Interface. This allows full control of the unit and the ability to generate a user defined audio tone sequence.

In addition, a remote port on the rear provides a simple interface to control the unit and has several outputs to indicate which tone sequence is active.

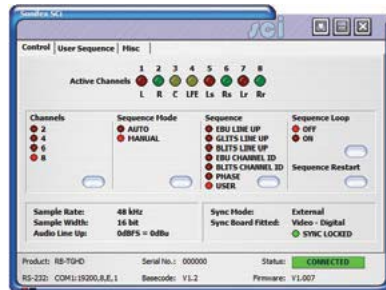

SCI Control Page.



SCI Miscellaneous Page.

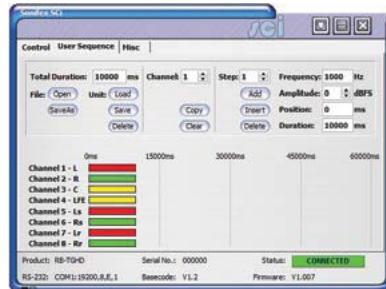

SCI User Sequence Page.

### Specification For RB-TGHD(B & X)

#### Audio Specification

Analogue Output Impedance:	<50Ω
Digital Output Impedance:	110Ω balanced 75Ω unbalanced
Dynamic Range:	>100dB
Max Output Level:	+24dBu
Distortion & Noise:	<-85dB THD+N at 1kHz
Crosstalk:	<-110dB (20Hz to 20kHz) for analogue outputs

#### Front Panel Controls

Channels:	2, 4, 6 or 8
Sequence Mode:	Auto or Manual
Sequence:	EBU R49 stereo line-up GLITS stereo line-up BLITS stereo line-up EBU R49 channel ID BLITS channel ID Phase User defined (using SCI)
Sequence Loop Mode:	On or Off (enables looping of current sequence)

Digital Sample Frequency:	32kHz, 44.1kHz, 48kHz, 88.2kHz 96kHz, 176.4kHz or 192kHz (via DIPSwitches)
---------------------------	---

Digital Sample Width:	16bit or 24bit (via DIPSwitches)
-----------------------	----------------------------------

Audio Line-Up:	0dBu to +24dBu in 1dB steps ref FSD (via DIPSwitches)
----------------	---

Channel Identification:	LEDs indicating 1-8 and L, R, C, LFE, Ls, Rs, Lr and Rr
-------------------------	---

#### Rear Panel Connections

Analogue Outputs:	8 x XLR 3 pin male (balanced)
-------------------	-------------------------------

Digital Outputs:	4 x AES/EBU XLR 3 pin male (balanced) or 4 x BNC female (un-balanced)
Digital Input:	Word clock on BNC
Remote I/O Port:	25-way 'D'-type socket 17 inputs, 7 tally outputs
Serial Comms Port:	9-way 'D'-type socket
Mains Input:	Filtered IEC, continuously rated 85-264VAC, 47-63Hz, 60W peak, 30W average
Fuse Rating:	Anti-surge fuse 1A 20 x 5mm

#### Equipment Type

RB-TGHDB:	Multi-channel HD tone generator with BNC digital outputs
RB-TGHDX:	Multi-channel HD tone generator with XLR digital outputs

#### Physical Specification

Dimensions (Raw):	48cm (W) x 10.8cm (D) x 4.3cm (H) 19" (W) x 4.3" (D) x 1.7" (H) (1U)
Dimensions (Boxed):	59cm (W) x 27.5cm (D*) x 11cm (H) 23.2" (W) x 10.8" (D*) x 4.3" (H)
Weight :	Nett: 1.3kg    Gross: 1.9kg Nett: 2.9lbs    Gross: 4.2lbs

#### Accessories

RB-SYA:	Analogue video sync board (NTSC, PAL & SECAM)
RB-SYD:	Digital video sync board (SD-SDI & HD-SDI)
RB-SYE:	AES/EBU sync board
RB-RK3:	1U Rear panel rack kit for large Redboxes

## CM-AESX3 Single 3 Way AES/EBU Passive Splitter With XLR Connectors



**Category:** Audio Distribution Amplifiers.  
**Product Function:** 1 input, 3 output AES3 distribution amplifier.  
**Typical Applications:** Distribution of AES3 source to 3 mixing consoles.  
**Features:** No power needed, can apply 110Ω termination to unconnected outputs, transformer based solution provides reliability.



CM-AESX3 Front & Rear View.

The CM-AESX3 is a passive “one-to-three” splitter housed in a small but robust aluminium box. It splits a single AES3 digital audio source to up to three destinations, using Neutrik XLR connectors.

The CM-AESX3 solves a range of digital signal distribution problems, where correct termination is essential to maintain signal integrity. The input signal is split through high quality transformers and 110Ω termination can be applied, to unconnected outputs.

The CM-AESX3 requires no power to operate, ensuring your audio remains connected from source to destination(s) without interruption from power failures.

### Specification For CM-AESX3

#### CM-AESX3 Technical Specification

##### CM-AESX3: Cable Drive Capability

The table below sets out the minimum signal amplitude required to drive 100m (cumulative) of 110Ω twisted pair cable, based on the sample rate of the digital audio:

Sample Rate	Minimum Signal Amplitude
32kHz	*2Vpk-pk
44.1kHz	*2Vpk-pk
48kHz	*2Vpk-pk
88.2kHz	5Vpk-pk
96kHz	5Vpk-pk

\* Minimum of 2Vpk-pk is defined by the AES3 format specification.

The table below sets out the minimum signal amplitude required to drive 30m (cumulative) of 110Ω twisted pair cable, based on the sample rate of the digital audio:

Sample Rate	Minimum Signal Amplitude
176.4kHz	3Vpk-pk
192kHz	3Vpk-pk

#### Connections

Inputs: 1 x XLR 3 pin female  
 Outputs: 3 x XLR 3 pin male

#### Equipment Type

CM-AESX3 Single 3 way AES/EBU passive splitter with XLR connectors

#### Physical Specification

Dimensions (Raw): 7.7cm (W) x 8.3cm (D) x 4.2cm (H)  
 3.0" (W) x 3.3" (D) x 1.7" (H)  
 Dimensions (Boxed): 22.9cm (W) x 12.7cm (D) x 7.6cm (H)  
 9.0" (W) x 5.0" (D) x 3.0" (H)  
 Weight: Nett: 0.22kg Gross: 0.33kg  
 Nett: 0.49lbs Gross: 0.73lbs



## CM-AESB3 Single 3 Way Passive AES3ID Splitter With BNC Connectors



**Category:** Audio Distribution Amplifiers.

**Product Function:** 1 input, 3 output AES3 distribution amplifier.

**Typical Applications:** Distribution of AES3 source to 3 mixing consoles.

**Features:** No power needed, can apply 110Ω termination to unconnected outputs, transformer based solution provides reliability.

The CM-AESB3 is a passive “one-to-three” splitter housed in a small but robust aluminium box. It is designed to split a single AES3ID digital audio source up to three destinations, using female BNC connectors.

Particularly useful in a video production and broadcast environment, the CM-AESB3 splits the input signal through high quality transformers. 75Ω termination can be applied, if desired, to unconnected outputs to maintain optimum carrier parameters.

The CM-AESB3 requires no power to operate, ensuring your audio remains connected from source to destination(s) without interruption from power failures.

### Specification For CM-AESB3

#### CM-AESB3: Cable Drive Capability

Cumulative cable drive capability of 100m of 75Ω coaxial cable at sample rates up to and including 96kHz.

#### Connections

Inputs: 1 x BNC female  
Outputs: 3 x BNC female

#### Equipment Type

CM-AESB3 3 Way passive AES3ID splitter with BNC connectors.

#### Physical Specification

Dimensions 7.7cm (W) x 8.3cm (D) x 4.2cm (H)  
(Raw): 3.0" (W) x 3.3" (D) x 1.7" (H)

Dimensions 22.9cm (W) x 12.7cm (D) x 7.6cm (H)  
(Boxed): 9.0" (W) x 5.0" (D) x 3.0" (H)

Weight: Nett: 0.22kg Gross: 0.33kg  
          Nett: 0.49lbs Gross: 0.73lbs



CM-AESB3 Front & Rear View.

## CM-MS3 Single 3 Way Passive Microphone Splitter



**Category:** Audio Distribution Amplifiers.  
**Product Function:** To split a microphone or line level signal to 3 independent outputs.

### Typical Applications:

To share microphones between radio/TV/production studios.

### Features:

- Passive transformer design.
- Ground lift switch.
- External or looped phantom power inputs.
- External +48V phantom power input.

The CM-MS3 is a passive “one-to-three” splitter housed in a small but robust aluminium box. It is designed to split a single microphone or line source to up to three destinations, using Neutrik XLR connectors.

### Wide Signal Range Capability

The CM-MS3 uses high quality audio transformers that are capable of accepting input levels up to +18dBu, making the splitter useful in both microphone and line level splitting applications.

### Versatile Phantom Powering Options

The CM-MS3 offers three methods of providing phantom power to a microphone connected to its input:

- From the external +48VDC power connector.
- From a microphone amplifier connected to output 1 (direct)

- From a microphone amplifier connected to output 2 (phantom loopback)

Controlling which method is used to provide phantom power is achieved with simple push switches. It is possible to concurrently power a microphone using any two of the above methods without degrading audio performance, thus providing power supply redundancy.

### Ground Loop Hum Elimination

Ground loop hum problems can be quickly eliminated using the push switches to lift pin 1 of the output connectors (output 2 and 3 only).



### Specification For CM-MS3

Test	Conditions	Results
Frequency Response:	Ref. -6dBu, 1kHz Source impedance = 150? Load impedance = 10k?	10Hz - 30kHz ±0.5dB
Total Harmonic Distortion:	Ref. +3dBu, 50Hz Source impedance = 150? Load impedance = 10k?	0.02%
Total Harmonic Distortion 0.1%:	Ref. 0.1%THD+N, 50Hz Source impedance = 150? Load impedance = 10k?	+13dBu
Total Harmonic Distortion 1%:	Ref. 1%THD+N, 50Hz Source impedance = 150? Load impedance = 10k?	+18dBu
Common Mode Rejection Ratio:	Ref. 20kHz Source impedance = 600? Load impedance = 10k?	>60dB

### Connections

Inputs:	1 x XLR 3 pin female (balanced, can be unbalanced)
Outputs:	3 x XLR 3 pin male (balanced, can be unbalanced)
DC Phantom Power Input:	+48V DC, 2.5mm socket

### Equipment Type

RB-MS3	Single 3 way passive microphone splitter
--------	--

### Physical Specification

Dimensions (Raw):	7.7cm (W) x 8.3cm (D) x 4.2cm (H) 3.0" (W) x 3.3" (D) x 1.7" (H)
Dimensions (Boxed):	22.9cm (W) x 12.7cm (D) x 7.6cm (H) 9.0" (W) x 5.0" (D) x 3.0" (H)
Weight:	Nett: 0.30kg    Gross: 0.40kg Nett: 0.66lbs    Gross: 0.88lbs



## Professional PCIe Sound Cards & Radio Capture Cards

### Professional PCIe Sound Cards

PC-AD2 2 Stereo Analogue I/O & 2 Stereo AES-3 I/O PCIe Half Height Sound Card	150
PC-DIG4 Digitorc 4, 4 Stereo AES-3 I/O PCIe Sound Card	153
PC-AUR44 Auricon 4.4 PCIe Analogue Sound Card	154

### Radio Capture Cards

PC-DAB1-4 Multi-Ensemble DAB+/DAB Radcap PCIe Card	155
PC-FM6-32 FM Radcap PCIe Card (6 to 32 Channels)	156
PC-AM6-32 AM Radcap PCIe Card (6 to 32 Channels)	157

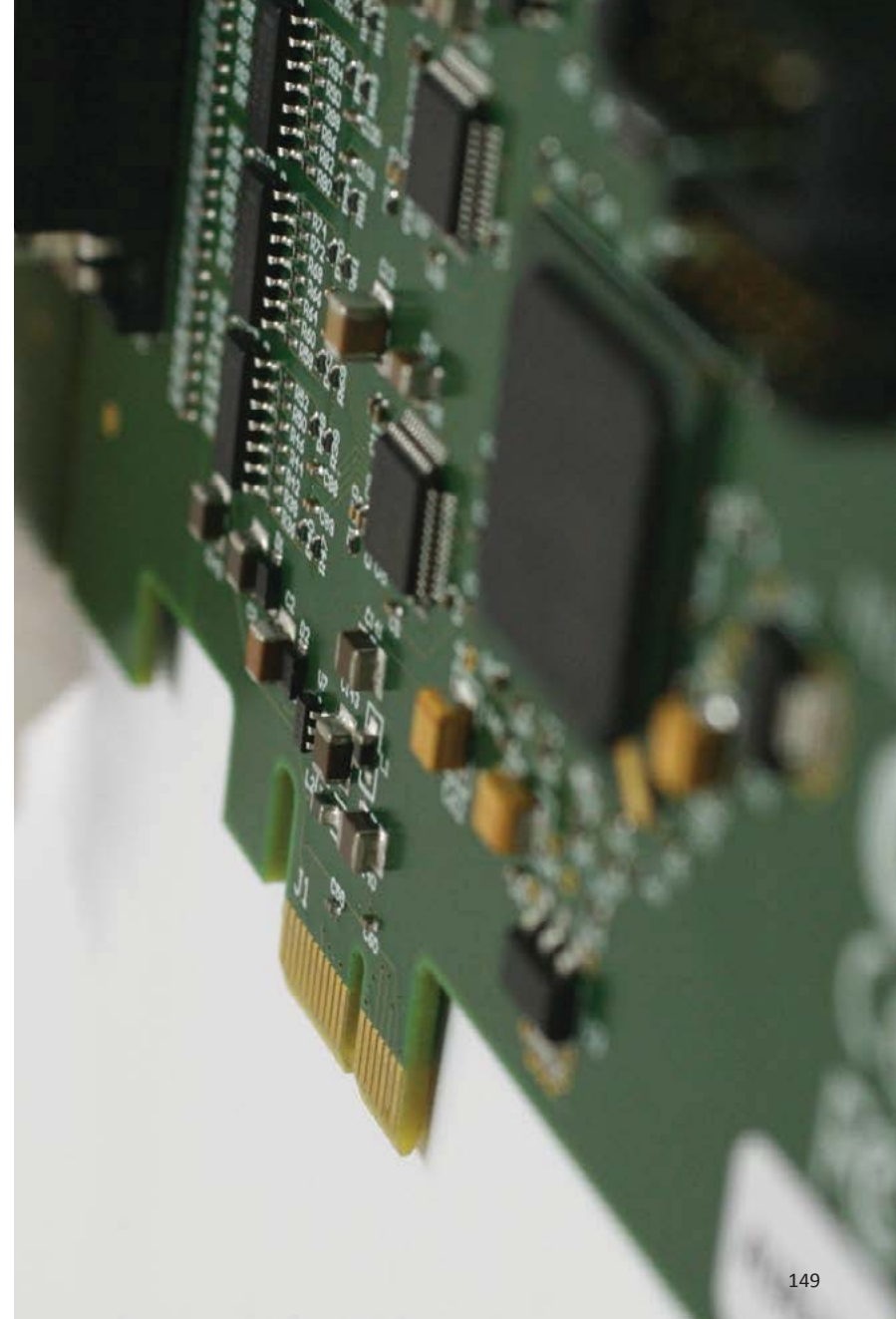

## Professional Sound Cards

These professional sound cards and radio capture cards were precision engineered in Australia. Use of the highest quality components & excellent electronic design give these cards the flattest frequency response in the business.

### PC-AD2 2 Stereo Analogue I/O & 2 Stereo AES-3 I/O PCIe Half Height Sound Card



**Category:** Professional Sound Cards & Radio Capture Cards.

**Product Function:** Provides two AES-3 and two balanced analogue audio inputs and outputs for use in a PC.

**Typical Applications:** Audio workstations, recording studios, automation systems, audio logging, multi-channel payout.

**Features:**

- 2 independent transformer-coupled AES-3 inputs and outputs.
- 2 independent high level balanced stereo inputs and outputs.

- One of the stereo line inputs can act as a dual mono or stereo mic input with +48V phantom power and limiter.
- 1 AES-11 synchronisation input.
- 2 opto isolated GPIOs.
- 24-bit audio resolution.
- Sampling rates up to 192kHz.
- Asynchronous sampling rate converters on each input.
- Card synchronisation to any input, AES-11 input or other PC-AD2 card.
- 32 and 64 bit drivers for Windows7/8/10, Windows Server 2008/R2, 2012/R2.
- WDM-compliant supporting Wave, DirectSound, DirectShow and Core Audio APIs.
- Simultaneous record/play per channel.

**24**<sup>BIT</sup>  
**192**<sup>KSS</sup>

The PC-AD2 is a dual stereo analogue input/output and dual stereo AES-3 digital input/output sound card in the PCIe half height format. One of the analogue inputs can be used as a mic input, there is a dedicated AES-11 sync input and also 2 GPIOs. It is fully compatible with the Windows™ Wave, DirectSound, DirectShow, MCI and Core Audio APIs, supporting audio up to 24 bit, 192kHz.

The PC-AD2 is a professional-quality half-height PCIe audio input-output card, offering both analogue and AES-3 stereo inputs and outputs. It is supplied with a Windows WDM driver to provide full sound card functionality on Windows 7, 8, 8.1, 10 and Windows Server 2008 R2, 2012 and 2012 R2. Many of the modern smaller PC systems only have space for half height PCIe cards – the PC-AD2 card has been designed with this in mind allowing a high channel count in a small format card.

The PC-AD2 has two stereo analogue inputs (the first of which can be used as a dual mono or stereo microphone input) and two stereo analogue outputs, two stereo AES-3 inputs and two stereo outputs, a dedicated AES-11 sync input and two general purpose (GPIO) inputs and outputs.

When acting as a microphone input, phantom power can be applied at +48V to the microphone input connection, but is removed if Line Input 1 becomes active. An audio limiter on the mic input automatically reduces the microphone gain if the recording level approaches clipping.

The peak analogue level sets the clipping threshold for the analogue inputs to one of +15, +18, +20, +22 or +24dBu. With the Windows endpoint faders set to maximum, these levels correspond to full scale on the software audio streams.

The card's core sampling rate can be synchronised to an external source chosen from either of the AES-3 inputs, the dedicated AES-11 sync input or by using the inter-card cable (PC-AD2SY) for synchronising to another PC-AD2.





The PC-AD2 Properties/Configuration Page.

Independent asynchronous sampling rate conversion on the inputs supports rates from 32kHz to 192kHz, while the output rate can be configured as 192kHz, 96kHz, 88.2kHz, 48kHz, 44.1kHz or 32kHz, either free-running or locked to an AES11 reference on any of the digital inputs. Software sampling rate conversion is automatically inserted by Windows when the application rate does not match the hardware rate, ensuring that files of any sample rate can be played and recorded. Extended software bit depths of 32 and 24 bits are supported as well as 16 and 8 bits for playback and recording. For each AES-3 input, the received sampling rate, frame lock and sampling rate converter status is shown.

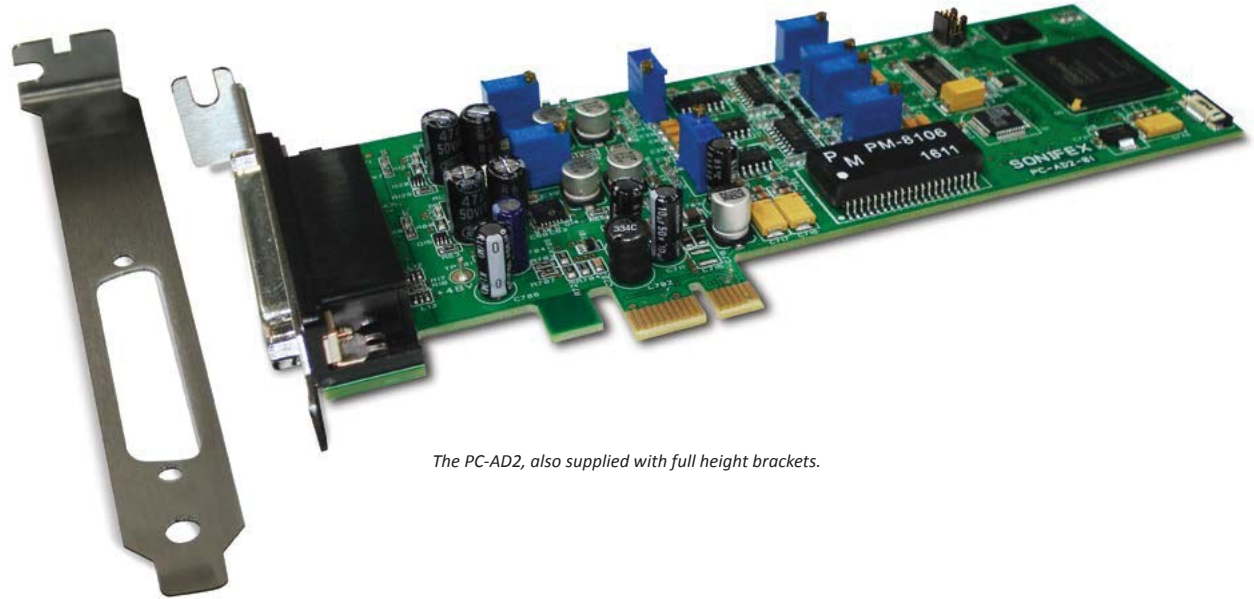

The PC-AD2, also supplied with full height brackets.

The playback and recording topology is virtualised because Windows treats each input source as its own 'endpoint'. Endpoints are the physical audio sources and destinations, such as microphones, speakers and line connectors. Each of the PC-AD2 card's physical line inputs is represented by an endpoint device, and as the hardware has separate A/D converters or AES-3 receivers for each one, they can be used simultaneously. A Microphone endpoint is also created which is shared with analogue Line Input 1 endpoint. The Windows mixer API is virtualised for each application, providing just a mute and volume control for each endpoint and affecting only the audio going to and from that application.

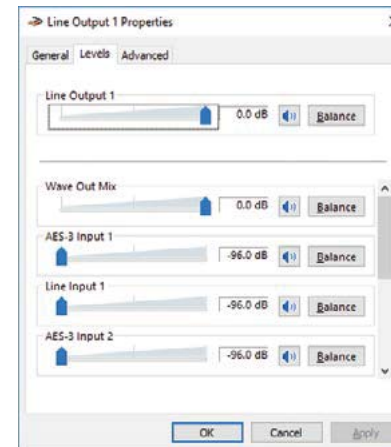

The PC-AD2 Line Output 1 Properties Page.

The PC-AD2 has two optically-isolated general purpose inputs and outputs which are accessed through a programming API supplied with the driver package. A demo program is included with the driver package to illustrate the operation of the GPIO API and to quickly test the GPIO functionality.

All the standard Windows audio APIs are available including the Core Audio API, Wave, DirectSound, DirectShow, MCI and MIDI playback, as are a variety of audio compression modes via the Windows Audio Compression Manager or other software compression systems.

Multiple cards may be installed in a single PC.

A 44-pin high-density D-type connector to XLRs & 9 pin D-type breakout lead is offered as an option, the PC-AD2BC.

### Specification for PC-AD2 2 Stereo Analogue I/O & 2 Stereo AES-3 I/O PCIe Half Height Sound Card

#### Operating Systems Supported

Platform:	Windows 7, 8, 8.1 and 10 (32-bit and 64-bit versions Server 2008 R2, 2012 and 2012 R2.
-----------	--

#### PCIe Specification

Card Interface:	Single lane PCIe 1.1
-----------------	----------------------

#### Audio Specification

Analogue Sampling Rate:	32kHz, 44.1kHz, 48kHz, 88.2kHz, 96kHz or 192kHz
Analogue Resolution:	24 bits
Dynamic Range:	>100dB typical (unweighted)
Analogue THD+N:	< 0.0015% (-96dB)
Analogue Input Interface:	2 x stereo balanced analogue line (1 can be switched to dual mono or stereo microphone)
Analogue Input Impedance:	20k $\Omega$ (balanced line), 2.5k $\Omega$ (microphone)
Analogue Output Impedance:	120 $\Omega$ (balanced)
Analogue Maximum Signal:	+15dBu, +18dBu, +20dBu, +22dBu, +24 dBu (software settable)
Microphone Sensitivity:	-58dBu to +2dBu for full scale input
Microphone E.I.N.:	-119dB (unweighted) (Sample rate 48kHz, max gain, 200 $\Omega$ source)
Microphone CMRR:	77dB @ 1kHz, 77dB @ 10kHz
Microphone Phantom Power:	+48V (software enabled)
Frequency Response:	Input – 1Hz to 88kHz Output – 1Hz to 88kHz (192kHz hardware sampling rate)

Digital Audio Interface:	2 x AES-3 (formerly known as AES/EBU) inputs/outputs
Digital Input Impedance:	110 $\Omega$ transformer coupled
Synchronisation Input:	1 x AES-11 input synchronisation:
Output Sampling Rates:	32kHz, 44.1kHz, 48kHz, 88.2kHz, 96kHz and 192kHz
Input Sampling Rates:	32kHz to 192kHz
Software Sampling Rates:	Any rate from 10Hz to 384kHz
Software Resolution:	32, 24, 16 or 8 bits
GPIO Inputs:	Optically isolated, 2.5 to 50V on (2.5 to 50mA).
GPIO Outputs:	Optically isolated, 5mA max on, 80V max off.
Connector:	44-pin high-density D-type female

#### Equipment Type

PC-AD2	2 Stereo analogue I/O & 2 stereo AES-3 I/O PCIe half height sound card
--------	--

#### Physical Specification

Dimensions (Raw):	18cm (L) x 7.0cm (H) x 2cm (D) 7.1" (L) x 2.8" (H) x 0.8" (D)
Dimensions (Boxed):	27cm (L) x 22.5cm (H) x 6cm (D) 10.6" (L) x 8.9" (H) x 2.4" (D)
Weight:	Nett: 0.10kg Gross: 0.20kg Nett: 0.2lbs Gross: 0.4lbs

#### Accessories

PC-AD2BC	PC-AD2 full XLR & 9 pin D-type breakout cable
PC-AD2SY	Cable to sync 2 x PC-AD2 cards

## PC-DIG4 Digitorc 4, 4 Stereo AES-3 I/O PCIe Sound Card



**Category:** Professional Sound Cards & Radio Capture Cards.

**Product Function:** Provides four AES-3 audio inputs and outputs for use in a PC.

**Typical Applications:**

Audio workstations, automation systems, audio logging, multi-channel playout.

**Features:**

- 4 independent transformer-coupled AES-3 inputs and outputs.
- 24-bit audio resolution.
- Sampling rates up to 96kHz.
- Asynchronous sampling rate converters on each input.
- Card synchronisation to any input or NTP-locked system clock.
- 32 and 64 bit drivers for Windows XP, & Windows 7/8/10.
- WDM-compliant supporting Wave, DirectSound, DirectShow and Core Audio APIs.

**The Digitorc 4 has four AES-3 stereo input and output channels on a Windows platform and is fully compatible with the Wave, DirectSound, DirectShow, MCI and Core Audio APIs.**

On the card is implemented both a single lane bus-master PCIe interface and four x 24-bit AES-3 codecs. Independent asynchronous sampling rate conversion on the inputs supports rates from 32kHz to 96kHz, while the output rate can be configured as 96kHz, 88.2kHz, 48kHz, 44.1kHz or 32kHz, either free-running or locked to an AES3 or AES11 reference on any of the inputs. When used with an internet time standard (e.g.ntp.org), a very precise sampling rate can be achieved.

Software sampling rate conversion is automatically inserted by Windows when the application rate does not match the hardware rate, ensuring that files of any sample rate can be played. Extended software bit depths of 32 and 24 bits are supported as well as 16 and 8 bits for playback and recording.

The playback topology consists of a master output level, mute control and peak meter, a wave level and mute control, and input monitor level and mute controls for each of the line inputs. The record topology consists of a master input level, mute control and peak meter, line input level controls for each of the physical inputs and a digital loopback level control and mute. The range



*The Digitorc 4, 4 Stereo AES-3 I/O PCIe Sound Card*

on the input and output master controls is -96dB to +6dB, while the individual line controls range from -96dB to 0dB. The mixer functions allow inputs to be mixed back into each output, while a digital loopback is available from each playback channel into its corresponding record channel.

High quality electrostatically-shielded transformers are used on all the inputs and outputs to give superb performance.

Multiple cards may be installed in a single PC.

A 25-pin D-type connector to 8 x XLR breakout lead is offered as an option.

### Specification for PC-DIG4 Digitorc 4 AES3 Sound Card

**Operating Systems Supported**

Platform:	Windows XP, Server 2003, Vista, Server 2008, Windows 7, Server 2008 R2, Windows 8 and Server 2012 (32- and 64-bit versions), Windows 10
-----------	---

**Features**

Card Interface:	Single lane PCI Express version 1.1
Line Interface:	Transformer coupled AES3 (AES/EBU)
Line Output Sampling Rate:	96kHz, 88.2kHz, 48kHz, 44.1kHz or 32kHz (configurable)
Line Input Sampling Rate:	32kHz to 96kHz via independent asynchronous sampling rate converters
Audio Resolution:	24 bits
Sampling Rate Accuracy:	+/- 5ppm
External:	AES11 compliant synchronisation:
Frequency Response:	DC to 43.5kHz (at 96 kHz sampling)
Connector:	25-pin D-type female

**Equipment Type**

PC-DIG4	Digitorc 4 4 stereo AES-3 I/O PCIe sound card
---------	---

**Physical Specification**

Dims (Raw):	14cm (L) x 12.5cm (H) x 2cm (D) 5.5" (L) x 4.9" (H) x 0.8" (D)
Dims (Boxed):	27cm (L) x 22.5cm (H) x 6cm (D) 10.6" (L) x 8.9" (H) x 2.4" (D)
Weight:	Nett: 0.10kg      Gross: 0.20kg Nett: 0.2lbs      Gross: 0.4lbs

**Accessories**

PC-DIG4BC	Digitorc 4 XLR breakout cable
-----------	-------------------------------

## PC-AUR44 Auricon 4.4 PCIe Analogue Sound Card



**Category:** Professional Sound Cards & Radio Capture Cards.

**Product Function:** Provides four stereo balanced analogue audio inputs and outputs for use in a PC.

**Typical Applications:**

Audio workstations, automation

systems, audio logging, multi-channel layout.

**Features:**

- 4 independent high level balanced stereo inputs and outputs.
- 24-bit audio resolution.
- Sampling rates up to 192kHz.
- 32 and 64 bit drivers for Windows XP, & Windows 7/8/10.
- WDM-compliant supporting Wave, DirectSound, DirectShow and Core Audio APIs.
- Simultaneous record/play per channel.

**The Auricon 4.4 is a professional quality 4 stereo input and 4 stereo output analogue PCIe audio card. The inputs and outputs can be reconfigured as separate mono channels, giving eight inputs and outputs.**

It is supplied with a Windows WDM driver to provide full sound card functionality under Windows XP, Server 2003, Vista, Server 2008, Windows 7, Server 2008R2, Windows 8, Server 2012 & Windows 10.

The card uses 24-bit 192kHz sigma-delta converters which pass data to and from the PC via a single lane PCI Express interface. An onboard FPGA provides audio buffering, level adjustment and mixing functions. Hardware sampling rates of 48kHz, 96kHz and 192kHz

are available, with the Windows sampling rate converter transparently providing support for other rates. The card supports extended bit depths to 32 bit and the software sampling rate and bit depth (32, 24, 16 or 8 bits PCM) can be set independently for each input and output channel.

Windows Wave, DirectSound and DirectShow API's are supported, as are a variety of audio compression modes via the Windows Audio Compression Manager or other software compression systems. On Windows Vista/Server 2008 and later systems, the Core Audio API is also fully supported.

There are four configuration settings for the Auricon 4.4, these being Mode (stereo/mono), H/W Sampling Rate, Input Coupling



*The Auricon 4.4 PCIe Analogue Sound Card*

and Nominal Line Level. The mode may be configured as either stereo or mono. In mono mode the number of input and output channels that Windows sees is doubled. The nominal line level can be set to +8dBu, +4dBu or 0dBu. In each case the clipping level is 16dB above the nominal level. The input coupling can be set to either DC or AC (the default is AC).

The playback topology consists of a master output level, mute control and peak meter, and input monitor level and mute controls for each of the line inputs. The record topology consists of a master input level, mute control and peak meter, and level controls and mutes for the physical input and digital loopback. The digital loopback allows the output of the card to be digitally mixed back into the input. The range on the input and output

master controls is -96dB to +6dB, while the individual line controls range from -96dB to 0dB.

Multiple cards may be installed in a single PC.

A 44-pin high-density D-type connector to XLRs breakout lead is offered as an option.

### Specification for PC-AUR44 Auricon 4.4 PCIe Analogue Sound Card

#### Operating Systems Supported

Platform:	Supports Windows - XP, Server 2003, Vista, Server 2008, Windows 7, Server 2008 R2, Windows 8, Server 2012 (32-bit and x64 versions), Windows 10
-----------	---

#### Audio Specification

Dynamic Range:	114dB typical (unweighted)
Input Impedance:	20k (balanced)
Output Impedance:	40Ω (balanced)
Maximum Signal:	+24dBu (34.6Vp-p)
Frequency Response:	Input – DC to 88kHz (DC coupling) 1Hz to 88kHz (AC coupling) Output – DC to 88kHz (192kHz hardware sampling rate)
Connector:	44-pin high-density D-type female

#### Equipment Type

PC-AUR44	Auricon 4.4 PCIe analogue sound card
----------	--------------------------------------

#### Physical Specification

Dims (Raw):	14cm (L) x 12.5cm (H) x 2cm (D) 5.5" (L) x 4.9" (H) x 0.8" (D)
Dims (Boxed):	27cm (L) x 22.5cm (H) x 6cm (D) 10.6" (L) x 8.9" (H) x 2.4" (D)
Weight:	Nett: 0.10kg      Gross: 0.20kg Nett: 0.2lbs      Gross: 0.4lbs

#### Accessories

PC-AUR44BC	Auricon 4.4 XLR breakout cable
------------	--------------------------------

## Radio Capture Cards

Radio capture cards don't have inputs and outputs, other than an aerial to capture the required signal. They allow a PC to record or monitor a number of DAB/DAB+, FM or AM radio channels so are useful for logging and monitoring applications.

### PC-DAB1-4 Multi-Ensemble DAB+/DAB Radcap PCIe Card



**Category:** Professional Sound Cards & Radio Capture Cards.

**Product Function:** Simultaneous audio capture of multiple DAB services for use in a PC.

**Typical Applications:**

Audio logging, station monitoring, media tracking.

**Features:**

- Simultaneous capture of every audio service across multiple ensembles.

- Available in 1, 2, 3 or 4 ensemble versions with field expansion option.
- Tunes Band III (174-240 MHz) using standard European channel numbers.
- DAB+ and legacy DAB supported.
- Each service appears as a standard audio input device.
- 32 and 64 bit drivers for Windows Vista, Windows 7,8,10.
- WDM-compliant supporting Wave, DirectSound, DirectShow and Core Audio APIs.
- API for monitoring, control and PAD extraction.
- Sample application for displaying DLS text and MOT slideshow.

The PCIe DAB+/DAB radio capture card receives and decodes the entire contents of up to four DAB+/DAB ensembles, rendering each audio service as a virtual Windows audio capture device for use with multi-channel recording or monitoring software.

Broadcast data services, including DLS text and MOT slideshows, are also available through a simple application programming interface.

The card supports both legacy DAB MP2 audio coding as well as the new HE-AAC v2 encoding used with DAB+ broadcasts.

Any application that records from standard wave input devices can be used to record the audio streams from the DAB+ Radcap. A recording level and mute control are provided for each service through the devices' mixer ports.

A sample monitor application is included which displays a control panel for each card and creates buttons for each audio service. When a button is clicked, it plays the audio through the default output device while



The PC-DAB1 Multi-Ensemble DAB+/DAB Radcap PCIe.

displaying information obtained from the service and any DLS text and MOT images being broadcast.

The number of ensembles is factory-set as 1 (PC-DAB1), 2, 3 or 4 (PC-DAB4) but is field-expandable through a purchased expansion key. Multiple cards can be installed, allowing simultaneous monitoring or recording of more than four ensembles.

A sample application is provided with the card, allowing monitoring of DAB+/DAB audio and data as well as providing diagnostic ensemble spectrum displays, signal quality indicators and an uncorrected error counter. Each card panel displays the ensemble name and identifier, along with the phase reference correlator level and signal spectrum.

#### Specification for PC-DAB1-4 Multi-Ensemble DAB+/DAB Radcap

##### System Requirements

Platform:	Windows Vista, Server 2008, Windows 7, Server 2008 R2, Windows 8, Server 2012 (32-bit and 64-bit versions supported), Windows 10 (Note: Windows XP and Server 2003 are not supported)
Processor:	2GHz quad-core or better
Memory:	1GB minimum
Motherboard:	PCIe socket, single lane or greater
Other:	Sound card or motherboard sound port for monitoring

##### Specifications

Tuning Range:	Band III (174-240 MHz)
DAB Format:	Mode 1
RF Input:	BNC connector
PCIe Interface:	Single lane PCIe 1.1
Number of Ensembles:	Factory-configured for 1, 2, 3 or 4 ensembles (field-expandable for an additional fee)
Total Number of Services:	128
Error Correction:	Soft-decision Viterbi inner decoder, Reed-Solomon outer decoder
Audio Decoding:	MP2 and HE-AAC v2
Audio Format:	48kHz 16-bit stereo (other application sampling rates and bit depths supported through the Windows SRC) (24kHz and 32kHz services are internally up-converted to 48kHz)
Decoding Latency:	3 seconds
<b>Equipment Type</b>	
PC-DAB1-4	Multi-ensemble DAB+/DAB radcap PCIe card
<b>Physical Specification</b>	
Dims (Raw):	14cm (L) x 12.5cm (H) x 2cm (D) 5.5" (L) x 4.9" (H) x 0.8" (D)
Dims (Boxed):	27cm (L) x 22.5cm (H) x 6cm (D) 10.6" (L) x 8.9" (H) x 2.4" (D)
Weight:	Nett: 0.10kg    Gross: 0.20kg Nett: 0.2lbs    Gross: 0.4lbs



## PC-FM6-32 FM Radcap PCIe Card (6 to 32 Channels)



**Category:** Professional Sound Cards & Radio Capture Cards.

**Product Function:** Simultaneous audio capture of multiple FM radio stations for use in a PC.

**Typical Applications:**

Audio logging, station monitoring, media tracking.

**Features:**

- Simultaneous capture of multiple FM

stations.

- Available in 6, 12, 18, 24 and 32 station versions with field expansion option.
- Tunes 87.5-108.5 MHz in 25kHz steps.
- Stereo and RDS decoding.
- Each station appears as a standard audio input device.
- 32 and 64 bit drivers for Windows XP and all later versions, as well as Debian Linux.
- WDM-compliant supporting Wave, DirectSound, DirectShow and Core Audio APIs (Windows) and ALSA (Linux).
- API for monitoring and control.

**The FM Radcap PCIe is a radio capture card designed for simultaneous recording of multiple radio stations. The frequency of each station is set in software and its audio appears as a standard Windows audio input device. RDS decoding is also supported.**

The card uses a high-speed A/D converter to digitise the entire FM band, with up to 32 individual tuners. The Radcap achieves exceptionally low audio distortion through the use of linear phase filtering and mathematically precise FM demodulation and stereo decoding. FM demodulation and stereo decoding is done in FPGA

fabric, while RDS decoding, if enabled, is performed in the driver using the host CPU's SSE-2 instruction set. This division of labour between the FPGA and driver allows greatest flexibility in catering for future baseband technologies while minimising the CPU overhead of the card.

A WDM driver for Windows XP (SP2 or later), Server 2003, Vista, Server 2008, Windows 7, Server 2008 R2, Windows 8, Server 2012 & Windows 10 is supplied as well as software for setting the tuner frequencies and monitoring the received audio. A programming API and DLL for software control and monitoring are also supplied.



*The PC-FM6-32 FM Radcap PCIe Card (6 to 32 Channels).*

The card can be configured to operate in stereo, mono or paired mono (two mono stations combined on a 2-channel audio stream) modes. Multiple cards can be used in a single PC, subject to available CPU bandwidth. The audio de-emphasis may also be set to either 50us or 75us. In Australia, New Zealand and Europe 50us is used, while in the USA and Canada 75us is used.

A utility called FMSpectrum is supplied. This displays the RF spectrum from 85MHz to 111MHz, using data from the card's front-end 256-point FFT and may be useful in selecting the best location for the antenna or resolving interference problems.

The card is factory-configured for 6 (PC-FM6), 12, 18, 24 or 32 (PC-FM32) stations, but may be expanded in the field for an additional charge.

### Specification for PC-FM6-32 FM Radcap PCIe (6 to 32 channels)

**System Requirements**

Platform:	Windows XP (SP2 or later), Server 2003, Vista, Server 2008, Windows 7, Server 2008 R2, Windows 8 and Server 2012 (32-bit and 64-bit versions), Windows 10
Processor:	2.5GHz Pentium 4 or better
Memory:	256 MB minimum (1GB for Vista Windows 7/Server 2008, 2GB for Windows 8/Server 2012)
Bus:	Single lane PCI Express v1.1
Other:	Sound card or motherboard sound port for monitoring

**Specifications**

Tuning Range:	87.5MHz to 108.5MHz in 25kHz steps
Sensitivity:	10uV for 40dB S/N
Maximum Input:	150mV RMS
RF Input Impedance:	75Ω
De-emphasis:	Configurable as 50us or 75us
Audio Distortion:	<0.01%
Audio Sampling Rate:	48kHz (all other rates automatically supported via Windows sampling rate converter)
Number of Stations:	6, 12, 18, 24 or 32 (factory configured but end-user expandable)
RDS Decoding:	Optionally enabled in driver configuration

**Equipment Type**

PC-FM6-32	FM Radcap PCIe card (6 to 32 channels)
-----------	--

**Physical Specification**

Dims (Raw):	14cm (L) x 12.5cm (H) x 2cm (D) 5.5" (L) x 4.9" (H) x 0.8" (D)
Dims (Boxed):	27cm (L) x 22.5cm (H) x 6cm (D) 10.6" (L) x 8.9" (H) x 2.4" (D)
Weight:	Nett: 0.10kg      Gross: 0.20kg Nett: 0.2lbs      Gross: 0.4lbs

## PC-AM6-32 AM Radcap PCIe Card (6 to 32 Channels)



**Category:** Professional Sound Cards & Radio Capture Cards.

**Product Function:** Simultaneous audio capture of multiple AM radio stations for use in a PC.

**Typical Applications:**

Audio logging, station monitoring, media tracking.

**Features:**

- Simultaneous capture of multiple AM stations.
- Available in 6, 12, 18, 24 and 32 station versions with field expansion option.
- Tunes 500-1610 kHz in 1kHz steps.
- Each station appears as a standard audio input device.
- 32 and 64 bit drivers for Windows XP and all later versions, as well as Debian Linux.
- WDM-compliant supporting Wave, DirectSound, DirectShow and Core Audio APIs (Windows) and ALSA (Linux).
- API for monitoring and control.

**The AM Radcap PCIe card is a radio capture card designed for simultaneous recording of up to 32 radio stations. The frequency of each individual station may be set in software and its audio appears as a standard Windows audio input device.**

The AM Radcap uses a high speed analogue-to-digital converter to digitise the entire AM band, with advanced digital signal processing on a Spartan 6 FPGA used to tune and extract the audio for each individual station. It can be configured to either create a separate audio stream for each station or to pair stations together as 2-channel streams.

A WDM driver for Windows XP, Windows 7/8/10 and other versions is supplied as well software for setting the tuner frequencies and monitoring the received audio.

A recording level control, mute control and peak meter are provided for each station (or pair of stations) through the devices' mixer ports. The default level setting is 50%, and at this setting 100% modulation will produce a peak audio level 6dB below clipping.

A utility called AmSpectrum is supplied. This displays the RF spectrum from 500kHz to 1700kHz and may be useful in selecting the best location for the antenna or resolving interference problems. The receiver bandwidth can be set to wide (default) or



*The PC-AM6-32 AM Radcap PCIe Card (6 to 32 Channels).*

narrow. The narrow setting restricts the audio response to about 3kHz, which may be useful in noisy environments.

A utility program called Tuner is also supplied which can be used to set the frequency of each station and to monitor each station through the PC's standard sound card or motherboard sound port. The Tuner program also provides relative signal strength indicator bars which may be useful in adjusting antenna placement.

The card is factory-configured for 6 (PC-AM6), 12, 18, 24 or 32 (PC-AM32) stations, but may be expanded in the field for an additional charge.

### Specification for PC-AM6-32 AM Radcap PCIe (6 to 32 channels)

**System Requirements**

Platform:	Windows XP, Server 2003, Vista, Server 2008, Windows 7, Server 2008 R2, Windows 8, Server 2012 (32-bit and 64-bit versions), Windows 10
Processor:	1GHz Pentium II or better
Memory:	128MB minimum (1GB for Vista and later systems)
Bus:	Single lane PCI Express v1.1
Other:	Sound card or motherboard sound port for monitoring

**Specifications**

Tuning Range:	500kHz to 1710kHz in 1kHz steps
Sensitivity:	50uV for 40dB S/N
RF Input Impedance:	50Ω
Filter Attenuation:	82dB at 15kHz or more from centre frequency
Audio Bandwidth:	5kHz
Audio Distortion:	<0.1%
Audio Sampling Rate:	22.05kHz (other rates supported via Windows SRC)
Number of Stations:	6, 12, 18, 24 or 32

**Equipment Type**

PC-AM6-32	AM Radcap PCIe card (6 to 32 channels)
-----------	--

**Physical Specification**

Dims (Raw):	14cm (L) x 12.5cm (H) x 2cm (D) 5.5" (L) x 4.9" (H) x 0.8" (D)
Dims (Boxed):	27cm (L) x 22.5cm (H) x 6cm (D) 10.6" (L) x 8.9" (H) x 2.4" (D)
Weight:	Nett: 0.10kg    Gross: 0.20kg Nett: 0.21lbs    Gross: 0.4lbs





# Flashlog8

## Audio Logging

<b>Net-Log Network Audio Logger</b>	160
<p>The Net-Log has been specifically designed for long-term recording and archival by the use of a dedicated hardware recording platform with a simple network connection for audio playback. Playback software on a network connected PC streams the audio to the desktop where it can be played out or saved as a file.</p>	
<b>Net-Log-Win Software</b>	162
<b>Mentor Time-Server</b>	165
<b>PC-FLS8 Flashlog 8 Audio &amp; Radio Capture Logging Software</b>	166
<p>Flashlog 8 is configurable, ultra powerful multi-channel logging software. It makes use of separate Sonifex hardware (sound and radio capture cards) to provide a host of logging features on a single PC platform.</p>	
<b>PC-FLS8LT1 Flashlog 8 Single Stereo Channel Logging Software</b>	168
<b>PC-FLS8LT2 Flashlog 8 Two Stereo Channel Logging Software</b>	168
<b>PC-RACK Industrial PC Racks for Audio Logging</b>	169





## Net-Log Network Audio Logger



**Category:** Audio Logging.

**Product Function:** To record 4 mono channels for long term archival and play back over a network.

**Typical Applications:**

Recording radio station off air transmissions for regulatory purposes, recording board room proceedings, recording courtroom trials.

**Features:**

- Dedicated reliable multi-channel recording hardware.
- Easy to use Windows™ remote operation for playback, archiving,

streaming and configuration.

- Independently configurable channel pairs to record at different sample rates, different bit rates and in mono or stereo.
- Recording duration configuration of the channels to suit your needs, e.g. 2 channels of low quality logging for 12 months together with two channels of high quality logging for 1 month, on one machine.
- Record inputs can be controlled remotely, e.g. snoop recording from mic-live output of a mixer.
- Automated voice recording - each channel can start and stop recording automatically by setting audio threshold levels, which means that it can be used for voice controlled systems and telephony recording.
- Up to 250,000 recordings per channel can be made.
- Each Net-Log has its own IP address, so a number of machines can be installed on the same network.
- Fail-safe alarm indicators and remotes.
- Password protection and security access rights to system.
- Support for hard disk sizes up to 2048GB.
- Recordings can be made using optional G.729 algorithm, allowing longer recordings and lower network traffic. G.729 audio quality is comparable to MPEG L2 at 32kbits/sec when used to record/playback speech.
- Recording on Net-Log can be controlled serially by Crestron and Televic board room controllers.

**The Net-Log has been specifically designed for long-term recording and archival by the use of a dedicated hardware recording platform that uses a simple network connection for audio playback.**

Playback software on a network connected PC streams the audio to the desktop where it can be played out or saved as a file.

The Sonifex Net-Log is a 4 channel audio logger which can record weeks of programming on a large internal hard-disk. The unit was designed as dedicated hardware for reliability reasons, i.e. there's no PC motherboard in this machine. Although PC based systems are great for playback, they generally aren't robust

enough for continuous recording 24/7/365. The Net-Log was designed from the ground up to offer :

- High reliability for continuous operation.
- High quality audio (mpeg compressed).
- Compatibility with existing broadcast & Windows based systems (bwf files can be saved).
- Automatic operation with very simple to use software.

All audio created by Net-Log is Windows Media Player™ compatible so files can be emailed to colleagues and customers and played out on any PC with a sound system.

There are many applications for Net-Log, from radio stations recording their broadcasts for regulatory purposes, to small call centres, law firms and security companies using them for monitoring. Net-Logs have been installed in court rooms & police interview rooms for audio surveillance and offer a cost saving desk-top based logging & filing system for audio.

### Radio Broadcast Logging

Where logging is required by the authorities, Net-Log provides a perfect, simple to use, elegant solution providing playback of requested recordings within seconds. But even if logging isn't regulatory, Net-Log can still deliver audio to the desktop of anyone at a radio station – you don't need to go to the racks-room, or central technical area to play out a recording previously made. So it has the following advantages :

- From their desktop, the sales team can check to make sure that advertising was played on time and can create audio files to email to customers.
- Program controllers can snoop on their presenters, checking performance and





### Key Features of Net-Log Hardware Description

Net-Log is a 1U rack-mount unit which has 4 mono record inputs on 3 pin XLR sockets with potentiometer gain controls and LED level indicators for each input. These accept 2 stereo, or 4 mono audio streams which are encoded in mpeg layer 2 format and written

to a large internal IDE hard disk drive. The size of the drive is continuously being increased as technology improves and Net-Log can support sizes up to 2048GB. Contact [sales@sonifex.co.uk](mailto:sales@sonifex.co.uk) for current drive sizes installed.

Net-Log has 2 serial ports on 9 pin D-types which are used to program the IP address of the machine and to upload new software. Additionally, there is a 15 pin D-type connector used for remote input recording

control and for alarm outputs (hard disk failure and archiving warning).

A 10Mbps RJ45 network port is used to connect Net-Log to your PC network and audio is streamed using TCP/IP. Audio can be streamed simultaneously to one, or many, PCs, as well as simultaneously archiving audio data to an IP server automatically in the background. All the Net-Log configurations and operational features are controlled from a connected PC using the Net-Log-Win software.

- checking that scheduled music was played.
- Station managers can check up on their competition and compare it with the sound of their own station.
  - The production team have much easier access to recorded audio from past radio shows for the preparation of future stings & trailers.

Net-Log records in mpeg layer 2, the standard for radio broadcasting, so that you can be sure that audio files created using Net-Log are compatible with almost every mpeg based automation system available. File downloads can be made in mp2, mp3 or linear .wav format, and broadcast wave format (bwf) files are supported as standard, ensuring tight integration with your playout systems.



## Net-Log-Win Software

There are 3 PC applications used to configure and control the Net-Log :

- Net-Util - A utility mainly used to initially configure the Net-Log and solve connection problems.
- Net-Log-Win - This is the application used on a day to day basis to control recording and playback.
- Auto-Archive - This is used to automatically archive/backup files to an IP server.

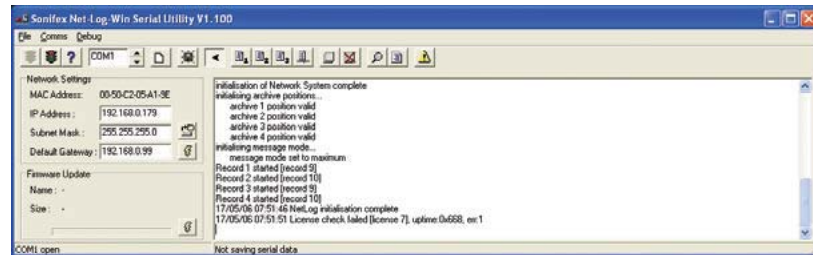

Net-Util Screen.

## Net-Util Application

The Net-Util program connects to a Net-Log unit via a serial (COM) port using the supplied serial cable, and is used to :

- Define the IP address of the connected Net-Log.
- Upload network settings.
- Monitor status messages.
- Upload new firmware into the Net-Log.

## Net-Log-Win Application

There are 4 main screens in Net-Log-Win which control and configure the connected Net-Log(s) : Recording, Playback, Archiving and Options. Access to these screens can be password protected and users can be configured either to View or Edit each screen. In the top part of the screen, a drop down list allows you to select which Net-Log you wish to connect to and the alarm states are also shown.

The Options screen is the place where you configure the settings of the connected Net-Log. The Options Archive screen in Net-Log-Win is used to configure the IP address and directory of the archiving destination and also to define archives to be written either as the cuts were recorded, or in files of a certain duration, e.g. hourly.

## Recording

Unlike normal hard-disk recording systems which stop when the disk is full, on reaching the “end” of the recording data space Net-Log begins to overwrite the oldest recordings, meaning that you always have access to the last recordings made, up to the size of the hard-disk. Additionally, it allows simultaneous recording and playback, so that you don’t have to stop the unit recording in order to search and play. Each channel can be given a service name for reference when searching for audio.

Recording can be controlled in 5 different ways :

- Using on-screen buttons in the Manual Record screen.
- Using the Program Record screen to start & stop recording at different times, using up to 20 programs. Programs can be saved to disk.

## Net-Log-Win Software & Licensing

The Net-Log is initially configured and controlled by Net-Log-Win software which is a suite of three applications which run under MS Windows™ 7/8/10. The software is sold either as a two stream, or a five stream licence. This means that each Net-Log on a network can simultaneously support either 2, or 5

simultaneous connections to it for playback or archiving. Note that you don’t need to buy a licence for each Net-Log if they are on the same network - if you have a number of Net-Logs on a single network, you only need to purchase a single set of licences, e.g. if you have 3 Net-Logs and buy a single Net-Log-Win05 5 stream licence, up to 5 different people can stream from each of

the 3 Net-Logs, i.e. 15 separate streams, provided that your network infrastructure can allow for this. Additionally, this is a buy once licence - we don’t ask you to re-buy it each year !

Net-Log licensing operates by you providing us with a licence code which appears in a licence window within Net-Log-Win. Once

we’ve verified the authenticity of your order, we send you an authentication code which you enter into the licence window to licence your Net-Log. If you don’t have a licence code, the Net-Log will continue recording but access to the recordings will be denied after 3 days.



Manual Record Screen.



Program Record Screen.

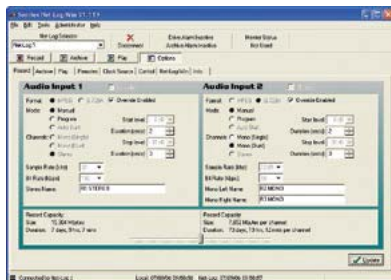

Options Record Screen.

- Using a remote input on the 15 way D-type connector.
- Automatically on voice/sound level, ideal for recording telephone conversations, configured in the Options Record screen.
- By Crestron and Televic board room controllers, via an RS232 serial connection. The controllers are mainly used in meeting rooms and allowing Net-Log to more easily be used for recording in this environment.

In the event of needing to record directly from the Net-Log, there is an emergency Record Control on the front panel of the machine.

### Net-Log-Win Playback

Net-Log-Win software for MS-Windows™ 7/8/10 is used to listen to audio recorded at a previous time and date, or for copying audio to a file, e.g. to email to a client or colleague.

In the Play screens, simply select a Net-Log and the required channel service name and a list of all the recordings made are displayed, sorted by recorded date and time. There are 4 ways to play audio :

- Using the Play Stream screen, selected audio is played out on your PC sound system within seconds.
- Using the Play Download screen, you can select a recording's date and

duration and a file is downloaded from the Net-Log and created on your local PC. You can then use separate applications to email the audio file, edit it, or save it to CD, or DVD. Files can be saved as .mp2, .mp3 or linear .wav.

- Using the Play Program screen, you can select a number of recordings, made at the same time over a number of days of the week and save them off to a single directory, e.g. for storing commercials from a particular customer. Files can be saved as .mp2, .mp3 or linear .wav.
- Using the Play File screen, you can open any previously saved audio file for playback. You can also play .mp3 and linear .wav files this way.

Additionally, a separate free player is available within Net-Log-Win to play any audio file created from a Net-Log.



Play Stream Screen.

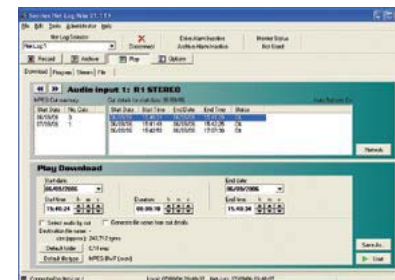

Play Download Screen.

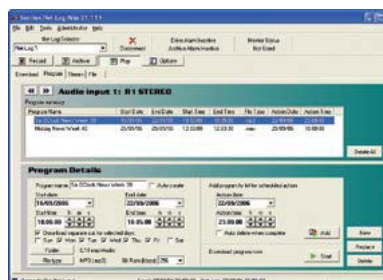

Play Program Screen.

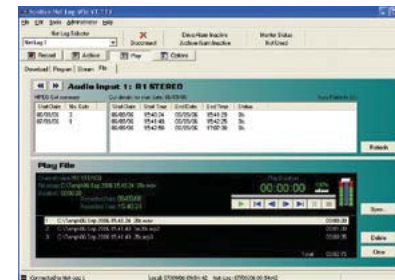

Play File Screen.

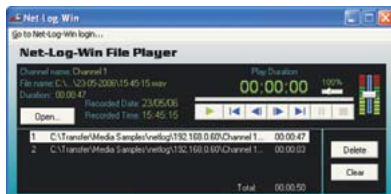

Net-Log-Win Free File Player.

### Archiving

You can use the Archiving function to automatically create long-term backups of the recordings by streaming audio to a separate server disk for archival purposes.

For each recorded channel, you can define an IP address and directory to save files to and Net-Log can create files on that directory either in the same way that they are recorded, or in files of a certain length, e.g. of 1 hour duration.

The Net-Log Auto-Archive utility is run on the server that you are archiving to. It has the following features :

- Simultaneous connection to multiple Net-Logs.
- Automatic log-in, archive and log-out process.
- Status display of Net-Logs on-screen in an easy to understand format.
- Status reports, error reports and archive alarm information can be emailed automatically at regular intervals.
- Can be used to check the status of
- Net-Logs even when archiving is not used or required.

*Note that Archiving uses a licence stream.*

### Specification For Net-Log

Audio Specification	
Input Impedance:	>10kΩ balanced.
Maximum Input Level:	+20dB.
Distortion:	<0.1% @ 1kHz + 16dBu.
Signal to Noise Ratio:	90 dB RMS A wtd. 22kHz bandwidth.
Wow and Flutter:	Unmeasurable.
Phase Error at 10kHz:	Unmeasurable.
Please note that the audio specification of the play output depends on the soundcard that you have installed on your PC. Net-Log is a recording device and has no audio output of its own.	
Rear Panel Connections, Controls and Indicators	
Analogue Inputs:	4 x XLR 3 pin socket.
Input Level Controls:	4 x Rotary pre-set potentiometers.
Network:	RJ45 10Mbps ethernet.
Network Status LEDs:	Rx, Tx, link and collision.
RS232:	2 x 9 way D-type plug.
Alarm Outputs and Remote Inputs:	15 way D-type plug.
Power:	IEC Power plug, 95-265 VAC, 47-63Hz.
Controls and Indicators	
Front Panel Controls:	Record control to instantly start recording
Front Panel Power Indicator:	Power LED (blue)
Front Panel Alarm Indicators:	2 x Alarm LEDs, disk drive alarm LED (red), archive alarm LED (red)
Front Panel Level Indicators:	4 x Analogue input level LED, 1 for each channel (green, orange, red)
Rear Panel Network Indicators:	4 x LEDs, receive (RX), transmit (TX), link and collision LEDs
Additional Information	
Sample Rates:	16kHz, 22.05kHz, 24kHz, 32kHz, 44.1kHz and 48kHz
Audio Format:	Mpeg layer 2 with bit-rates as below and G.729 low bit rate
Recording Types:	Mono, dual mono, stereo
Hard Disk Capacity:	A minimum hard-disk size of 1TB is fitted. Due to the rapidly changing nature

of disk capacities, the hard-disk size you buy may be larger than this.

PC Soundcard Needed:	Any windows compatible soundcard that can play PCM (.wav) audio files
Operating System:	Windows™ 7,8 or 10
Equipment Type	
Net-Log-01	Net-Log 4 channel audio logger, with large hard disk (contact sales @sonifex.co.uk for current sizes available)
Net-Log-Win01	Net-Log Windows™ software - 2 stream licence
Net-Log-Win05	Net-Log Windows™ software - 5 stream licence
Net-Log-UPS01	1U rack-mount UPS for use with Net-Log
Net-Log-G729	G.729 software licence for one Net-Log (up to 4 mono channels).
Physical Specification	
Dimensions (Raw):	1U 19" rack x 220mm deep 48cm (W) x 22cm (D) x 4.2cm (H) (1U) 1U 19" rack x 8.7" deep 19" (W) x 8.7" (D) x 1.7" (H) (1U)
Dimensions (Boxed):	56cm (W) x 30cm (D) x 18cm (H) 22" (W) x 11.8" (D) x 7.09" (H)
Weight:	2.5kg - 5.5lbs

### Record Duration

The table below shows the approximate record capacity at different bit-rates for one mono channel on a 1TB hard disk. For 4 mono channels, divide the figures by 4.

**Note:** Each pair of channels can be given a different bit-rate and \* indicates bit-rates for stereo channels only.

(kbit/sec)	Days	(kbit/sec)	Days
8	11572	112	826
16	5786	128	723
24	3857	*144	642
32	2893	160	578
40	2314	192	482
48	1928	*224	413
56	1653	*256	361
64	1446	*320	289
80	1157	*384	241
96	964		

### Specification For Net-Log UPS01

Output	
Output Power Capacity:	280 Watts/450 VA
Max Configurable Power:	280 Watts/450 VA
Nominal Output Voltage: 230V	
Output Voltage Distortion:	Less than 5% at full load
Output Frequency (sync to mains):	47-53Hz for 50 Hz nominal, 57 63Hz nominal
Crest Factor:	Up to 5 : 1
Waveform Type:	Stepped approximation to a sinewave
Output Connections:	(4) IEC 320 C13 (2) IEC Jumpers
Input	
Nominal Input Voltage:	230V
Input Frequency:	50/60Hz +/-3Hz (auto sensing)
Input Connections:	IEC-320 C14
Input voltage range for main operations:	160-286V
Input voltage adjustable range for mains operation:	151-302V

### Batteries & Runtime

Battery Type:	Maintenance-free sealed Lead Acid battery with suspended electrolyte: leakproof
Typical recharge time:	5 hours
Replacement Battery:	RBC18
RBC™ Quantity:	1
Typical Backup Time at half load:	19.4 minutes (140 Watts)
Typical Backup Time at full load:	5.9 minutes (280 Watts)
Runtime Chart:	Smart-UPS SC
Physical Specification	
Dimensions (Raw):	1U 48.3cm rack x 43.2cm (W) x 38.5cm (D) x 4.4cm (H) (1U) 1U 19"rack x 17" (W) x 15" (D) x 1.7" (H) (1U)
Dimensions (Boxed):	47.6cm (W) x 58.9cm (D) x 16.4cm (H)(1U) 18.74" (W) x 23.19" (D) x 6.45" (H)
Weight:	Nett: 10.2kg Gross: 13.0kg Nett: 22.4lbs Gross: 28.6lbs
Colour:	Grey



Net-Log UPS01.

## Mentor Time-Server

The Mentor Time Server is software which runs on a MS-Windows Windows™ 7/8/10 PC and synchronizes a number of MS-Windows Windows™ 7/8/10 PC client machines or Sonifex Net-Log units to its time. The client PCs or Net-Logs read the server time and have their time set using TCP/IP at regular intervals.

### Clock Sources

Mentor Server can be synchronised to NTP (Time servers on the Internet).

For pricing information, please contact the Sales Department.

### Sonifex Mentor Client Installation

The Mentor Client software can be installed on any number of PCs connected to network where a Mentor Server is located, but clock updates will only be performed up to the number of client licences installed on the server.

### Mentor Server

The Mentor Server to connect to is identified by its TCP/IP address.

### Equipment Type Mentor

MTS-5	Mentor Time-Server 5 client licence
MTS-25	Mentor Time-Server 25 client licence
MTS-100	Mentor Time-Server 100 client licence
MTS-500	Mentor Time-Server 500 client licence



# Flashlog 8

## PC-FLS8 Flashlog 8 Audio & Radio Capture Logging Software



**Category:** Audio Logging.

**Product Function:** Continuous audio logging software for analogue, AES-3, AM, FM, DAB+, IP audio and internet streams for long term archival and retrieval.

**Typical Applications:**

Compliance logging, air checking, content reuse, monitoring of competitors.

**Features:**

- Continuous recording from 7 days to up to 2 years, user selectable on each channel or ensemble, dependent on hardware & HDD size.

- Based on 64-bit Windows 7/8.1/10.
- Up to 64 analogue, AES-3 or IP-based (Axia or Wheatstone) line inputs supported.
- Up to 32 AM stations & 32 FM stations supported.
- Up to 4 DAB/DAB+ ensembles supported.
- Up to 32 internet radio streams supported.
- Contact-closure driven skimming option on line inputs (separate hardware required).
- Supports archiving - optional parallel recording of selected channels to an archive location on the network.
- Simultaneous network playback on multiple client PCs.
- Easy-to-use interface with rapid date/time navigation and waveform display.
- Playback metadata display of FM RDS, DAB DLS/Slideshow/EPG & internet stream metadata.

Flashlog 8 is configurable, ultra powerful multi-channel logging software. It makes use of separate Sonifex hardware (sound and radio capture cards) to provide a host of logging features on a single PC platform.

It can record from analogue and digital line inputs, IP based line inputs (Axia™, Wheatstone™ or Dante™), from the Sonifex radio capture cards and internet radio streams.

Up to 2 years of radio broadcasts or audio can be logged, depending on available hardware.

When also using the Sonifex PC-DAB DAB+ multi-ensemble PCIe Radcap card, the software records the entire contents of up to four ensembles. Decoding occurs during playback, showing DLS text, MOT slide shows and electronic programme guides along with the audio.

But DAB+ isn't all you get with Flashlog 8. By using suitable hardware, Flashlog 8 has the ability to record up to 64 stereo line channels, 32 stereo FM stations, 32 AM stations, 4 DAB+ ensembles and 32 internet radio streams, limited only by the number of PCIe slots on the motherboard that you use. (See later for the PC-RACK units that can be used with Flashlog 8 software).

The number of HDD logging days can be independently set for each line, AM or FM channel, and for each DAB+ ensemble.

Archiving also allows parallel recording of selected channels to a permanent archive location on the network, either continuously or on selected days and time ranges.

All text fields are Unicode-based, allowing multilingual display and entry.

Playback on both the logger and through Flashback 8 supports saving log extracts as MP3 as well as WAV, WMA and AVI files.

The Flashlog 8 recorder runs as a Windows service and is controlled from under the



Flashback 8 Playback Page.

Sources tab in the Flashlog application.

Each line source can be configured as Stereo, 2 x Mono, 1 x Mono or Hidden. When set to Hidden, the input is still being recorded, but the source doesn't appear on the playback screen. The number of recording days drop-down list is dynamically populated to ensure the hard drive space won't be exceeded. If line channel subcategories have been created, the subcategory can also be selected from a dropdown list. Each input can have a 12-character name, which is what appears on the playback button for that channel, and when 2 x Mono mode is selected, separate names are given to each channel. The audio compression rate can be set to 80kbps, 128kbps, 256kbps or lossless, and audio failure alarms can optionally be enabled.

When used with the PC-AM and PC-FM radio capture cards, AM and FM radio capture sources are shown next, with edit fields for

the frequency and an optional descriptive name. If RDS is present and no descriptive name has been entered, the transmitted station name is used and is dynamically updated should it be changed by the station. RF and audio signal levels are shown, along with stereo and RDS indicator lights for FM channels. Alarms (audio or carrier fail) can be optionally enabled. A drop-down list allows the number of logging days to be set, with the range determined dynamically from the available drive space.

When using the PC-DAB radio capture card, each DAB ensemble has a spectrum display, an RF level indicator, a phase reference correlator level, an uncorrected error count and an alarm enable checkbox. When alarms are enabled, the Configure button opens a dialog box allowing alarms to be enabled or disabled on individual services. The number of logging days for each ensemble is set from a drop-down list.

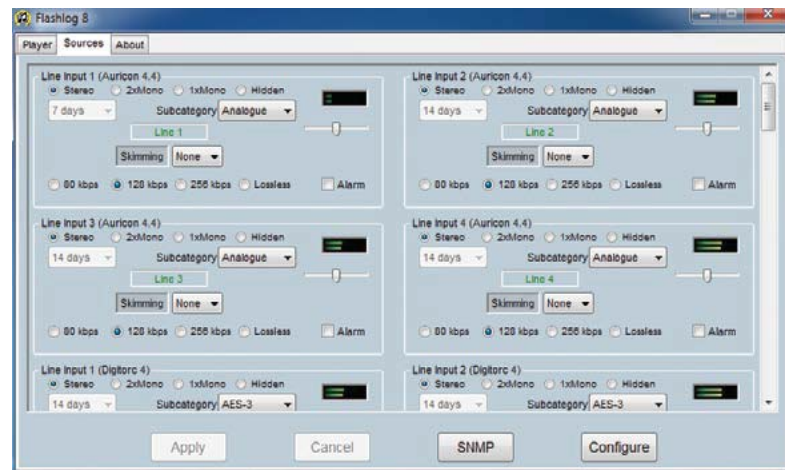

Flashlog 8 Source Page.

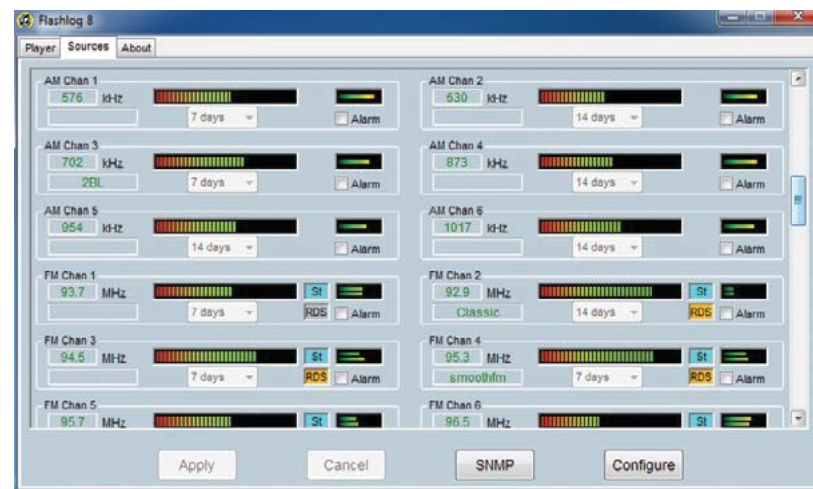

Flashlog 8 AM & FM Radio Capture Source Page.

Finally shown are the internet radio streams displaying the URL, stream status, bit-rate, audio coding and audio levels, with drop-down lists for setting logging days and alarm enable checkboxes. Audio level meters, based on analysing the compressed audio data, are also presented.

Additional buttons at the bottom of the Sources window provide further source and SNMP configuration.

The playback screen, available under the Player tab on the Flashlog unit and in the free Flashback network playback application, provides easy selection of audio source and playback date and time.

Across the top, tabs for each source category or subcategory select a group of up to 32 buttons, identified by the channel name. In the case of DAB sources,

the broadcast short service name is used.

The waveform display can span one minute, ten minutes, an hour or a day, by using 'span' buttons. The date is selected from a calendar control, with the time set either by using the up and down buttons or by directly typing into the hours, minutes and seconds fields. The playback position can also be adjusted by dragging on the ruler bar below the waveform.

A section of audio can be marked either with the mouse in the waveform window or by navigating to the start and end points and clicking on the Mark button. Once highlighted, the section can be saved to the Windows clipboard or to a file in WAV, WMA or MP3 format. For DAB channels, an AVI video file incorporating the slideshow and DLS text along with the audio can also be created.

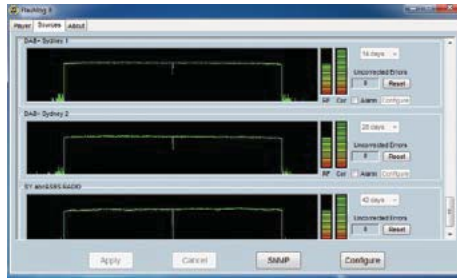

Flashlog 8 DAB Inputs Page.



Flashlog 8 Internet Radio Streams Page.

The display window on the lower left shows DLS text for DAB services, RDS radiotext for FM stations and artist/title metadata for internet streams. The window on the lower right shows skimming events for line channels, slideshows for DAB audio services, a program guide tree view for DAB EPG services and header information for internet streams.

Flashback can be simultaneously used on multiple workstations, up to the limit imposed by the recorder's operating system (20 users for Windows 7/8/10 or the number of installed CALs for server versions).



## PC-FLS8LT1 Flashlog 8 Single Stereo Channel Logging Software

## PC-FLS8LT2 Flashlog 8 Two Stereo Channel Logging Software

New licences of the Flashlog 8 software are now available to allow logging of either one or two stereo channels, together with IP audio streams.

Aimed at the community radio market, these new licences offer full Flashlog functionality for logging radio output.

A great value for money solution using your own PC hardware.

Flashback 8 Playback Page.

### Features

- Analogue, AES-3, Axia Livewire™, Wheatstone Wheatnet™ & Audinate Dante™ IP line inputs supported (Note separate proprietary drivers needed from the IP audio suppliers).
- Up to 64 stereo inputs supported, each reconfigurable as a pair of mono inputs.
- Up to four assignable line sub-categories for grouping channels.
- Selectable audio compression rates ranging from 80kbps to lossless.
- Adjustable no. of logging days per input.
- Recording time of up to two years, settable on each channel or ensemble (dependent on no. of channels, audio compression rate & HDD size).
- Operates on 64-bit Microsoft Windows™ 7/8.1/10 Professional operating system.
- Network playback using free Flashback 8 application (also compatible with Flashlog 5, 6 and 7 recorders).
- SNMP monitoring and alarms, including RDS / DLS text.
- Optional skimming control inputs supported.
- Live input monitoring on logger unit.
- Selectable audio failure alarms.

### AM & FM Radio Capture Using PC-AM & PC-FM Cards

- Up to 32 AM stations and 32 FM stations.
- Adjustable number of logging days on each station.
- All FM logging in stereo.
- Received signal strength, FM stereo pilot and RDS indicators.
- Live monitoring on logger unit.
- FM RDS radiotext logging.
- Selectable carrier & audio failure alarms.

### DAB+ Radio Capture Using PC-DAB Card

- Up to four DAB+ ensembles.
- Adjustable no. of logging days per ensemble.
- Entire MSC (main service channel) contents recorded.
- Receiver spectrum display, signal strength and quality indicators, and uncorrected error counter.
- Decodes legacy MP2 as well as HE-AAC v2 audio compression.
- Displays DLS text, MOT slides and electronic programme guide.
- Live monitoring of audio and data.
- Selectable ensemble, stream and audio failure alarms.

### Internet Stream Capture

- Up to 32 internet radio streams.
- HLS, Shoutcast, Icecast & RTMP protocols.
- MP3 and HE-AAC audio encoding.
- Metadata recording.



### Specification for Flashlog 8 Software

Recording Time:	7, 14, 28, 42, 60, 90, 100, 120, 180 days, 1 year or 2 years (individually settable on each channel or ensemble)
Analogue Line Inputs:	80kbps / 128kbps / 256kbps / lossless compression (selectable per channel).
AES-3 Line Inputs:	32kHz – 96kHz 24-bit sampling 80kbps / 128kbps / 256kbps / lossless compression (selectable per channel)
Axia Livewire:	Optional software driver supporting up to sixteen stereo inputs and playback output.
Wheatstone WheatNet:	Optional software driver supporting up to sixteen stereo inputs and playback output.
Internet Streams:	RTMP, Shoutcast, Icecast, HLS stream logging. MP3 and HE-AAC encoding. Maximum 32 streams.
Skimming Option:	Daily event list display linked to audio log. Sequential playing and archiving of multiple events. (Needs separate hardware).
AM Capture:	500kHz – 1710kHz tuning range (1kHz steps). 22.05kHz sampling. 32kbps compression. Maximum 32 stations
FM Capture:	87.5 – 108.5MHz tuning range (50kHz steps). 48kHz sampling. 64kbps compression. Maximum 32 stations. RDS radiotext logging.
DAB+ Capture:	Band III (174 – 240MHz) DAB Mode 1. Maximum 4 ensembles. Maximum 32 services per ensemble. Dynamic reconfiguration. DAB+ and Legacy DAB supported. Decoding for MP2 / HE-AAC v2 audio, DLS, JPEG / PNG images, EPG.
Internet Streams:	Shoutcast, Icecast & RTMP protocols.
SNMP:	Input audio / carrier / DAB status /RDS-DLS text monitoring. Selectable trap generation.

Axia Audio® & Livewire® are trademarks of TLS Corporation. WheatNet® & WheatNet-IP® are registered trademarks of Wheatstone Corporation, Dante® is a trademark of Audinate.

## PC-RACK Industrial PC Racks for Audio Logging

Sonifex can supply industrial rackmount PCs to run the PC-FLS8 Flashlog logging software.

### PC-RACK4D 4U Rackmount PC With Front Panel Display



The PC-RACK4D

This is a rugged industrial 4U rackmount PC to run the PC-FLS8 Flashlog 8 software which has a front panel LCD display with a pull-out drawer for the keyboard and mouse. So, it's completely self-contained and useful for secure logging environments. It has dual power supplies, 4 x PCI slots and 8 x PCIe slots. It uses an Intel i7 processor, has 8GB RAM, runs Windows 10 Professional and uses a reliable battery-backed Adaptec SATA RAID with 3 x 2TB Enterprise HDD. Finally there is also a DVD-RW drive.

The 8 x PCIe slots allow this PC to be fitted with multiple PC-AD2, PC-DIG4, PC-AUR44,

PC-FM, PC-AM and PC-DAB cards to produce a very powerful audio and radio capture logger.

### PC-RACK4 4U Rackmount PC

This is similar to the PC-RACK4D but doesn't contain the integrated display and has a separate USB keyboard and mouse. It has dual power supplies, 7 x PCI slots and 5 x PCIe slots. It uses an Intel i7 processor, has 8GB RAM, runs Windows 10 Professional and uses a reliable battery-backed Adaptec SATA RAID with 3 x 2TB Enterprise HDD. There is also a DVD-RW drive.

On this PC, there are 5 x PCIe slots which can be fitted with multiple PC-AD2, PC-DIG4, PC-AUR44, PC-FM, PC-AM and PC-DAB cards.



The PC-RACK4

### PC-RACK1 1U Rackmount PC

This is a 1U industrial rackmount PC to run the PC-FLS8 Flashlog 8 software. It has a single PCIe slot so can only be used with one PCIe audio or radio capture card, ideal for logging up to 32 FM, or 32 AM channels or 4 DAB ensembles. It uses an Intel i5 processor, has 8GB RAM, runs Windows 10 Professional and uses SATA RAID with 2 x 2TB HDD. It also has a DVD-RW drive and separate keyboard and mouse.



The PC-RACK1

Please note that the PC-FLS8 Flashlog 8 software is not automatically included with these systems and must be ordered separately. Also, as is common with PC systems, the specification can change so contact Sonifex to check the latest product specs.





*Sonifex S2 Digital I/O Analogue Radio  
Broadcast Mixer. Photo courtesy of Radio 10 Magic FM & Triple Audio.*



## Radio Broadcast Mixing Consoles

### S0 Radio Broadcast On-Air Mixer

The S0 is a high quality yet simple to operate radio broadcast mixer ideally suited to community radio stations, for educational purposes and for internet radio.

172

### S1 Radio Broadcast On-Air Mixer

The Sonifex S1 mixer is a high performance compact, low cost, fixed format mixing console designed for on-air radio use.

1876

### S2 Digital I/O Analogue Radio Broadcast Mixer

The S2 is a fully modular radio broadcast mixer offering digital audio quality with analogue reliability, using the latest technology components.

182

S2 Input Channels

183

S2 Output Channels

193

S2 Meterbridge Modules

197

S2 Chassis Sizes

201

S2 Script Spaces

202

S2-PSU Power Supply

204

S2-PSUS Dual Power Supply Switcher

205



*Sonifex S2 Digital I/O Analogue  
Radio Broadcast Mixer. Photo  
courtesy of [www.jingle24.com](http://www.jingle24.com).*



## S0v2 Radio Broadcasting On-Air Mixer



**Category:** Radio Broadcast Mixing Consoles - S0v2 Radio Broadcast Mixer.

**Product Function:** 9 Channel analogue fixed format on-air broadcast mixer.

**Typical Applications:** Community, student, hospital and small scale radio broadcast mixer, secondary or backup on-air mixer.

### Features:

- User friendly broadcast mixer.
- Clear, simple layout with no jargon.
- Designed for school & community radio.
- Nine multi-function channel mixer.
- Built in telephone interface.
- Skype PC interface on 3.5mm jack and USB.
- Built in headphone volume limiter.
- Large, simple LED volume display.
- Remote output for fader starts.
- Speaker muting when 'Mics' are on.
- External mic-light switching output.
- 'Programme' and 'record' outputs.
- 'Aux' input for iPod or MP3 players.
- Four microphone/line channels.
- Four stereo line channels.
- Machined luxury face plate in brushed aluminium finish.
- Switchable telephone/AUX channel.
- Stereo USB audio to and from a PC.
- Guest headphone 'talkback'.
- Reliable, low cost mixing solution.
- Rack or flush mountable.
- Integrated AC power supply.

The S0v2 is a high quality yet simple to operate radio broadcast mixer ideally suited to community radio stations, for educational purposes and for internet radio.

An upgrade to the original S0 mixer, it is easy to understand, the S0v2 includes a telephone hybrid for making and recording telephone calls and a 3.5mm stereo jack for plugging in an mp3 player. The addition of a USB port allows for recording to a PC and for playing a PC automation system directly through the mixer. The headphone outputs have a built in limiter to offer



S0 Radio Broadcast Mixer Rear.



hearing protection and the studio speakers mute when a microphone fader is open, with automatic mic live sign switching. The S0v2 allows presenters and DJs to be up and running quickly with a fully featured radio studio mixer.

#### Difference between the S0 and the S0v2:

The S0v2 has a machined luxury face plate in brushed aluminium finish and a Skype PC interface on 3.5mm jack and USB.

The Sonifex S0v2 mixer is a compact, low cost, fixed format broadcast mixing console designed for on-air radio use. It uses the same high quality circuitry and components as the Sonifex S2 and S1 mixers to provide an audio experience second to none. The S0v2 can be fitted flush into a desk-top or can be rack mounted directly using the front panel mounting holes.

The uncomplicated and intuitive front panel layout ensures that the unit appeals to novices and broadcast professionals alike, whilst a range of user configurable options allows for flexible operation.

The console consists of nine input channels:

- 4 x mono balanced XLR mic/stereo unbalanced RCA phono line inputs.
- 4 x dual stereo unbalanced RCA phono line inputs.



S0 Radio Broadcast Mixer Iso View.

- 1 x telephone balance unit (with line and handset ports)/stereo unbalanced RCA phono auxiliary input with a parallel 3.5mm stereo jack input on the front panel.

Providing in total 4 mic, 12 stereo line, 1 TBU & 1 stereo auxiliary inputs which you can switch between.

#### Input Channels

Input source buttons at the top of each channel strip are used to select the required mono or stereo source. The mixer has two main stereo buses, PGM (Program) and REC (Record), so each channel also has PGM and REC buttons to independently select which mixer bus the selected input is routed to.

mixer using the handset connection. The auxiliary channel can switch between 2 independent inputs, one on the rear panel and one on the front panel.

Any channel which has the fader up is routed to the selected output, either PGM or REC or both.

Gain for each channel is trimmed by the front panel TRIM control providing  $\pm 15\text{dB}$  of gain. A PAN/BAL(ance) control is available to facilitate stereo imaging.

The use of VCAs controlled by the ALPS long throw 100mm faders gives a smooth, repeatable response and ensures tight stereo tracking while eliminating mechanical and electronic noise.

#### USB Audio for Playback and Recording

The S0v2 has the option to send and receive audio over USB. This allows the audio on the REC bus to be sent to a PC for recording or monitoring purposes. Also, the S0v2 can receive a USB audio stream from a PC and route it to the auxiliary inputs on channel 8. Alternatively, this signal can be routed to channels 5, 6 or 7 if required.

#### Output Channels

The S0v2 has separate stereo PGM and REC bus outputs. The PGM bus is output on balanced stereo XLRs and the REC bus

The XLR microphone inputs on channels 1 to 4 have individually selectable +48V phantom power and a gain calibration potentiometer providing up to 65dB of gain for the pre-amp. Input channel 1 also serves as the microphone input for a dedicated talkback channel.

The stereo RCA phono line inputs on channels 1 to 8 have 10dB of gain at the input to compensate for unbalanced consumer inputs.

Input channel 9 is a TBU and stereo auxiliary input channel. The TBU allows direct connection to a telephone line and allows calls to be made and received through the



S0 Radio Broadcast Mixer Top View.

is output on unbalanced stereo RCA phono connectors. There are monitor outputs for presenter headphones, guest headphones and loudspeakers.

### Monitoring & Headphone Limiter

The monitor loudspeakers, presenter headphones and guest headphones are on 6.35mm stereo jack sockets and the headphones can be plugged in to the front and rear of the mixer. The monitor loudspeaker and headphone levels are independently variable between 0 (cut off) and 10 (max).

With the concerns over listening levels being too high in headphones, the addition of an adjustable limit level potentiometer

on the rear panel of the mixer is a great idea which limits the maximum level of the audio routed to the presenter and guest headphone outputs. An illuminated MUTE LED shows when a live microphone channel has muted the loudspeakers and there is a MUTE contact output available to illuminate a 'MIC LIVE' light via a 6.35mm stereo jack socket on the rear panel.

A three way electronically interlocking illuminated switch bank selects the source routed to the loudspeaker and headphone outputs from either PGM, REC or from an additional unbalanced stereo RCA phono input EXT 1. This external input can be

used for monitoring an off air signal or studio output.

Green illuminated AUTO CUE/PFL (pre fade listen) buttons adjacent to each level control allow the automatic monitoring of any channel that has been selected to pre-fade, either to the monitors or headphones.

For the presenter headphones, SPLIT CUE/PFL can be selected which places the selected source in mono in the left ear, and pre-fade in mono in the right ear.

### Metering

A pair of bright 21 segment LED meters can be configured to show either VU or PPM metering. The meters follow the selection of the presenter headphones including any pre-fade or split pre-fade function.

### Talkback

A separate TALKBACK button is provided to allow the presenter to talk to a guest on the guest headphones. The S0v2 uses input channel 1 as the talkback source.

### Channel Remotes

The remote outputs for each channel are highly configurable providing a comprehensive range of options to interface external equipment to the mixer. Each channel input has its own START and STOP remote controls which can be triggered when the channel is routed to the PGM or REC bus and the fader is opened or closed. The remotes can be set-up to be either pulsed or continuous latched outputs, and if in pulsed mode the

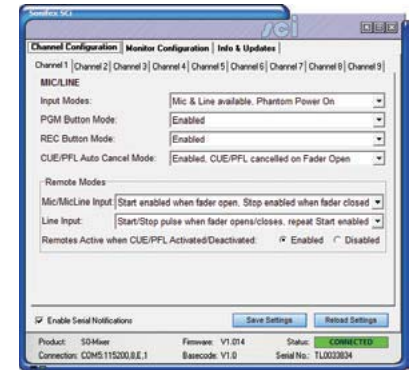

SCI Configuration Page.

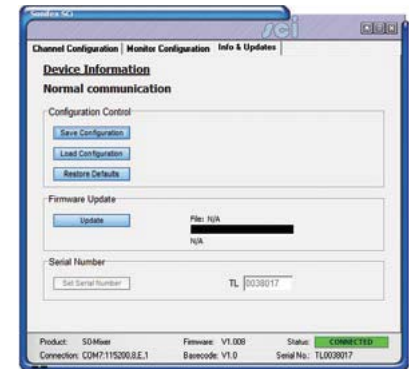

SCI Info & Updates Page.

START button has the capability to produce repeated start pulses.

### Configuration Settings

The S0v2 has a range of software configurable options which can be used to customize the operation of the mixer. It is possible to enable or disable specific inputs, enable phantom power for the microphone channels and limit which buses each channel can be routed to. Other settings



control auto cancelling of PRE FADE when the channel fader is opened and all the remote output configurations.

The S0v2 has an integral universal switch mode power supply, which uses an IEC mains inlet.



This product has settings that can be adjusted using the Sonifex SCi (Serial Control Interface) software.

**Specification For S0v2**

**Mic Inputs Audio Specification**

Input Impedance:	> 1k5Ω electronically balanced
Input Gain Range:	Preset pot +24dB to +67dB ref -50dBu, TRIM pot ± 15dB
Frequency Response:	40Hz to 20kHz -1dB, +0dB
Mic input E.I.N.:	-130dB with 150Ω source
Phantom Power:	+48V to each mic input (SCI selectable)
Common Mode Rejection Ratio:	> 60dB typically
Pan Range:	Off/-3dB Centre/Off

**Stereo Line Inputs Audio Specification**

Input Impedance:	> 20kΩ electronically unbalanced
Input Gain Range:	+10dB ref 0dBu at PGM output, TRIM pot ± 15dB
Frequency Response:	20Hz to 20kHz -0.5dB, +0dB
Noise (20Hz-20kHz):	-92dBu ref 0dB (fader down, no routing)
Total Harmonic Distortion:	0.015% at 1kHz, 0.015% at 10kHz ref +8dBu
Balance Range:	± 6dB

**Outputs Audio Specification**

Output Impedance:	PGM output: < 50Ω electronically balanced
REC output:	< 75Ω unbalanced Monitor output: < 75Ω unbalanced
Headphone output load:	> 16Ω, recommended 250Ω
Maximum Output:	PGM output: +26dBu balanced REC output: Level:+16dBu unbalanced

**Input & Output Connections**

Audio Inputs:	4 x Microphone XLR-3 pin sockets 12 x Pair stereo line RCA phono sockets 1 x Pair stereo aux RCA phono sockets 1 x Stereo aux 3.5mm jack socket
---------------	--

Audio Outputs:	2 x XLR-3 pin plug (balanced) REC: 1 x Stereo pair RCA phono sockets
Monitor Inputs:	1 x Stereo pair RCA phono sockets
Monitor Outputs:	5 x 6.35mm (1/4") stereo jack sockets (2 x presenter, 2 x guest, 1 x loudspeaker)
Remote Outputs:	9 x 6.35mm (1/4") stereo jack sockets (one per channel) 1 x 6.35mm (1/4") stereo jack socket for light control
Telephone:	2 x RJ11 6/4 (1 x line, 1 x handset)
USB Audio:	1 x Type-B receptacle
USB Serial:	1 x Type-B receptacle
Mains Input:	Filtered IEC, continuously rated 85 264VAC, 47-63Hz, 45w nominal, 50w peak
Fuse Rating:	Anti-surge fuse 2A 20 x 5mm
<b>Equipment Type</b>	
S0v2:	S0v2 radio broadcast mixer
<b>Physical Specification</b>	
Dimensions (Raw):	48.3cm (W) x 35.6cm (D) x 12.5cm (H) 19" (W) x 14" (D) x 4.9" (H)
Dimensions (Boxed):	67cm (W) x 44cm (D) x 25cm (H) 26.4" (W) x 17.3" (D) x 9.84" (H)
Cut-Out Dimensions:	44cm (W) x 34.7cm (D) 17.32" (W) x 13.66" (D)
Weight:	Nett: 8.5kg Gross: 10.12kg Nett: 18.7lb Gross: 22.26lb

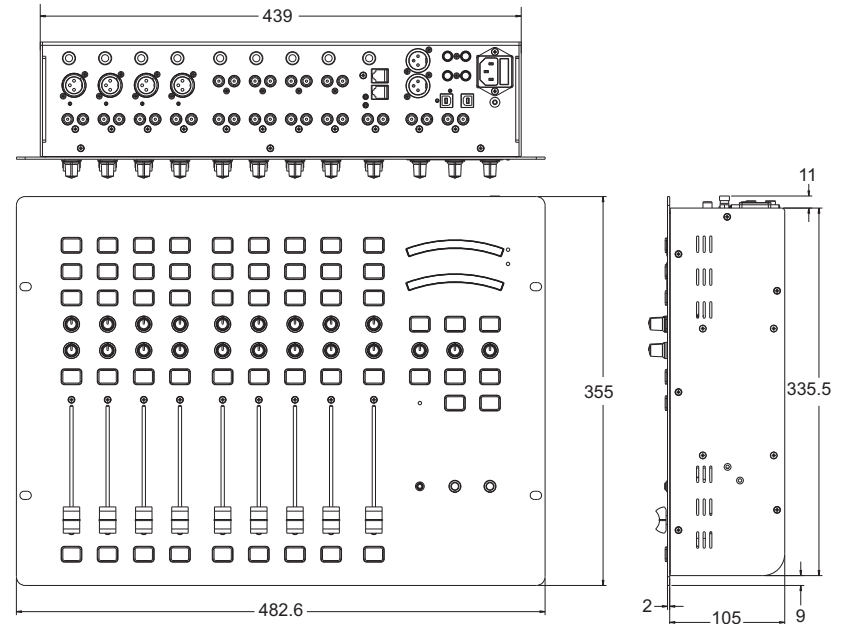

S0 Radio Broadcast Mixer Dimensions (in mm).





## S1 Radio Broadcast On-Air Mixer

The small radio mixer that's big on features.

The S1 has an amazing feature set and offers a proper broadcast solution to community, educational and student radio stations that need a versatile, reliable radio broadcast mixer. It has a 'no compromise on quality' approach with excellent mic amps, comprehensive facilities & simple, reliable operation.



S1 Digital/Analogue Radio Broadcast Mixer.



**Category:** Radio Broadcast Mixing Consoles - S1 Radio Broadcast Mixer.

**Product Function:** 9 Channel analogue fixed format on-air broadcast mixer.

**Typical Applications:** Community, student, hospital and small scale radio

broadcast mixer, secondary or backup on-air mixer.

**Features:**

- High performance, ultra-reliable on-air radio mixer.
- Low cost and easy to use.
- Small footprint, flush-mounting or rack-mounting.
- Analogue & digital inputs & outputs.
- Main stereo output bus plus 2 Aux output buses, pre or post fader

selectable.

- Rotating rear panel for ease of installation.
- Integrated power supply.
- Remote outputs per channel.
- Fader start of ancilliary equipment such as CD players.
- Programmable general purpose I/O.
- Monitor muting on mic live.
- Mic-live/on-air sign switching.
- Monitor outputs for presenter & guest

headphones, & speakers.

- Bright LED meter display PPM/VU selectable with separate meterbridge output.
- 100mm ALPS long-throw faders with control via VCAs.
- Separate telco & stereo cleanfeed o/ps for use with a telephone hybrid & codec respectively.
- Advanced automation facilities.
- Remote control via free SCI software.



S1 Digital/Analogue Radio Broadcast Mixer, Rear View.

The Sonifex S1 mixer is a high performance compact, low cost, fixed format mixing console designed for on-air radio use. It can be fitted flush into a desktop or can be rack-mounted by the addition of optional rack ears. The rear connectivity panel can be rotated 90° onto the base of the unit providing easier connection to the unit when it is rack-mounted. It has an integral universal switch mode power supply, which uses an IEC inlet.

It maintains the same front panel ease of use found on the Sonifex S2 whilst providing advanced automated features not seen on any other product currently available on the market.

The console consists of ten input channels:

- 2 x mono XLR mic/mono XLR line inputs.
- 1 x mono XLR mic/mono XLR telco input.
- 2 x mono XLR mic/mono XLR line inputs/ stereo ¼" jack unbalanced line input.

- 1 x stereo XLR line/stereo XLR cleanfeed input.
- 2 x stereo XLR line/stereo RCA inputs, one with a 3.5mm stereo aux input.
- 2 x stereo XLR line/stereo SPDIF & Toslink digital inputs.

Providing in total 5 mic, 4 mono line, 10 stereo analogue, 2 stereo digital, 1 telco & 1 stereo cleanfeed inputs which you can switch between.

### Wide-Ranging Input Channels

Input source buttons at the top of each channel strip are used to route the connected source to the mixer buses.

All of the balanced XLR input connectors have a 10dB gain switch on the rear panel for use with unbalanced or low level input sources. The XLR microphone inputs have individual +48V phantom power switches and a gain calibration potentiometer providing up to 65dB of gain for the preamp.



S1 Digital/Analogue Radio Broadcast Mixer, Top View.

Input channels 1 & 2 have 2 separate XLRs for microphone & balanced line input sources.

Input channels 3 and 4 use an XLR and a combination XLR/stereo jack connector to allow a microphone input and both a balanced mono or an unbalanced stereo line input to be used.

Input channel 5 acts as microphone input or as a telco input with a dedicated cleanfeed output, with available line hold remote for connection to a telephone hybrid.

Input channel 6 is a balanced stereo line input on XLR together with a stereo cleanfeed input on balanced XLR for use with ISDN codecs.

Input channels 7 & 8 have stereo balanced XLRs and stereo unbalanced phonos on the rear and channel 7 also has a 3.5mm insert jack socket on the front panel for use with an mp3 player/iPod.

Input channels 9 and 10 provide a stereo analogue XLR input and stereo digital S/PDIF and TOSLink optical inputs.

Any channel which has the fader up and the ON button selected is routed to the main PGM output(s).

Gain for each channel is trimmed by the front panel TRIM control providing  $\pm 12$ dB of gain.

Equalisation is provided on every input channel, allowing up to 7dB cut and boost at HF (6.5 kHz) and LF (100Hz). A PAN/BAL(ance) control is available to facilitate stereo imaging.

The use of VCAs controlled by the ALPS long throw 100mm faders give a smooth, repeatable response and ensures tight stereo tracking while eliminating mechanical and electronic noise.

### Analogue & Digital Outputs

The S1 has a multitude of output connectivity: one balanced stereo XLR PGM output, two balanced stereo AUX outputs on a 9-way D-type socket, a mono clean feed output on balanced XLR (for use with a telephone hybrid), a stereo cleanfeed output on stereo balanced XLRs (for use with an ISDN/IP codec) and monitor outputs for presenter headphones, guest headphones and loudspeakers. Additional outputs are provided for talkback on a 9-way D-type socket and metering using a 15-way D-type socket.

A digital stereo PGM output is provided in XLR AES/EBU or phono S/PDIF formats. The output can be referenced to an internal clock source between 32 kHz and 96 kHz or external synchronisation sources can be connected via S/PDIF, AES/EBU or BNC wordclock. The illuminated DIGITAL SYNC LED shows when the digital output is locked to either an internal or external clock.

### Two Auxiliary Buses

The S1 has two Auxiliary buses that can be configured in either pre-fade or post-fade mode. Each channel can be routed to these buses using the potentiometers provided on each channel strip. Each AUX output has a trim control knob operating between fully attenuated and unity gain. Aux buses can be used for a wide range of purposes including recording telephone conversations, generating different mixes for output, connecting to audio processing equipment and much more.

### Comprehensive Monitoring

The control room loudspeakers, presenter's headphones, and guest headphones are on 6.35mm stereo jack sockets. Front panel control knobs are used to vary the monitor and headphone levels and the presenter's headphones can be plugged in to the front and rear of the mixer. The control room monitor loudspeaker and headphone levels are variable between 0 (cut off) and 10 (max). An illuminated MUTE LED shows when a live microphone channel has muted the speakers and there are two pairs of MUTE contact outputs available to illuminate a 'MIC LIVE' light.

A five way electronically interlocking switch bank selects the source routed to the speakers and presenter's headphones from either of two external inputs (EXT 1, EXT

2), the PGM, or AUX Outputs. The buttons illuminate to show the selected source, PGM, AUX 1 and AUX 2 in green, EXT 1 and EXT 2 in red. The external inputs can be used for monitoring an off air signal or another studio output.

Green illuminated AUTO CUE/PFL buttons adjacent to each level control allow the monitoring of PFL when an input channel has been selected to CUE/PFL, either to the monitors or headphones.

For the Presenter headphones, SPLIT CUE/PFL can be selected which places the selected source in mono in one ear and PFL in mono in the other.

A pair of bright 21 segment LED meters can be configured to show either VU or PPM metering. The meters show either the PGM output or the selection heard in the presenter's headphones, selectable by PGM/MFM (Meter Follows Monitor) button.

### Talkback

A separate TALKBACK button is provided to allow the Presenter to talk to a Guest. The S1 uses input channel one as the talkback source. Global talkback can also be configured (see the Programmable GPIO section) to allow every mic channel to communicate with the Presenter and Guest headphones.

A separate TALKBACK 9-way D-type socket on the rear panel can be used to connect the talkback output and input to and from other studios.

### Configurable Remotes Per Channel

The remote outputs for each channel are highly configurable providing every possible option required to interface your external equipment to the mixer. Each channel input has its own START and STOP remote controls, except the microphone inputs which have only START outputs. (If you wanted a MIC stop control signal, you could configure this using a GPIO). Each remote can be configured to be triggered from a variety of sources, including the ON button and the CUE/PFL Button. The remotes can be set-up to be either pulsed or continuous latched outputs, and if in pulsed mode the ON button has the capability to produce repeated start pulses on additional ON button presses, when the channel is ON with the fader up.

In the case of the Telco & Stereo Cleanfeed outputs you may want to generate start and stop remotes independently of the position of the fader, so that the hybrid or codec can be triggered to connect before the channel is opened. This is possible in 'Telco Mode' where a 'start' is sent when the ON button is initially pressed & a 'stop' is sent when the ON button is pressed again, turning

the channel selection off. In addition the channel can be configured to show the state of the external equipment, e.g. using a tally back GPI signal from an automation system, the ON button can flash green when the end of a song is being reached.

### Programmable GPIOs

The S1 also has five General Purpose Inputs/Outputs (GPIO's) available. Each input/output has been designed to be very versatile & almost any operation with the mixer can be achieved when utilising them. A GPI can be configured using the SCI software to perform up to 10 different operations from a single input. For example, in an automated playlist situation, you may want to:

- Force 4 channels ON with the faders forced up.
- Force 4 channels to stereo Line Input.
- Mute the Control Room Monitors.



S1-RCK Optional S1 9U 19" Rack Ears.



This configuration would use 9 of the 10 operations available for an individual GPI.

The GPOs are equally powerful. The outputs can be configured to be pulsed or continuous, and active high or low. An output can be generated based on actions required. For example, a GPO can be configured to generate a global talkback function with a set-up so that:

- When Mic 2, Mic 3 & Mic 4 are all not live, generate a GPO continuous output.

The GPO could then be linked back into one of the GPI's with the input configured to:

- Force PFL on Mics 2, 3 & 4.
- Enable Auto CUE/PFL on Guest H/phones.

This would allow the guests to freely talk to each other until one of their microphones goes live. This is just an example of the potential uses of the programmable GPIOs.

### Remote Control & Configuration Using SCi Software

The S1 mixer is highly configurable and has numerous options allowing the mixer configuration to be tailored to your requirements. Using the freely available Sonifex SCi software, every parameter of the mixer can be set up with ease.

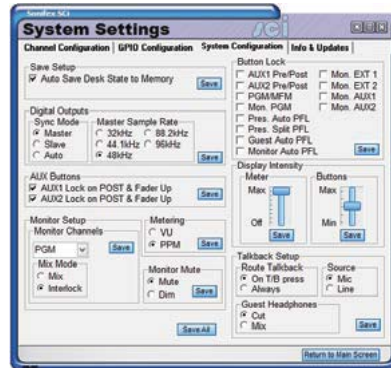

SCi Channel Configuration Page.

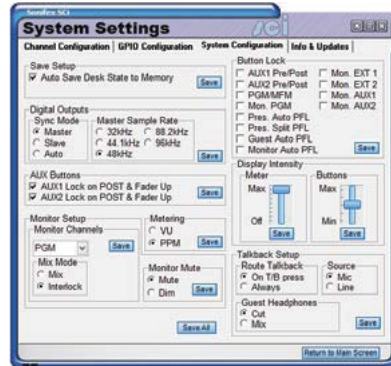

SCi System Configuration Page.



### Specification For S1

<b>Input / Output Impedances</b>	
Mic Input:	> 1k5Ω electronically balanced
Mono Line Input:	> 20kΩ electronically balanced
Stereo Line Input:	> 20kΩ electronically balanced
PGM Output:	< 50Ω electronically balanced
Monitor Outputs:	< 75Ω unbalanced
AES Input/Output:	110Ω
S/PDIF Input/Output:	75Ω
BNC Wordclock Input:	50Ω
<b>Input / Output Gain Range</b>	
Mic Input:	Preset pot +21dB to +64dB ref -50dBu, TRIM pot ± 12dB
Mono Line	Switch 0dB to +10dB ref 0dBu, Input: TRIM pot ± 12dB
Stereo	Switch 0dB to +10dB ref 0dBu, TRIM pot ± 12dB
Line Input:	Switch 0dB to +10dB ref 0dBu, TRIM pot ± 12dB
Telco Input:	Switch 0dB to +10dB ref 0dBu, TRIM pot ± 12dB
Stereo Cleanfeed Input:	Switch 0dB to +10dB ref 0dBu, TRIM pot ± 12dB
Digital Input:	0dBFS = +18dBu on input; TRIM pot ± 12dB allowing 0dBu to +24dBu
Digital Output:	0dBFS = +18dBu
<b>Frequency Response</b>	
Mic Input:	40Hz to 20kHz -1dB, +0dB
Line Inputs:	20Hz to 20kHz -0.5dB, +0dB
RCA Inputs:	20Hz to 20kHz -0.5dB, +0dB
<b>Noise (20Hz to 20kHz)</b>	
Mic Input E.I.N.:	-130dB with 150Ω source.
Stereo Inputs	-92dBu ref 0dB (fader down, no routing) -91dBu (fader down, one channel routed) -86 dBu (unity gain, one channel routed) -83 dBu (unity gain, two channels routed)
<b>Distortion</b>	
Total Harmonic Distortion:	0.015% at 1kHz, 0dBu 0.015% at 10kHz, 0dBu

<b>Crosstalk</b>	
Inter-Channel:	< -80dBu typically
<b>Equalisation</b>	
LF:	Shelving at 100Hz ± 7dB
HF:	Shelving at 6.5kHz ± 7dB
<b>Range</b>	
Pan Range:	Off/-3dB centre/off
Balance Range:	± 6dB
<b>Common Mode Rejection Ratio</b>	
Mic Input:	>60dB typically
<b>Digital I/O</b>	
Sync Input Sample Rate Range:	32kHz – 96kHz
Output Sample Rates:	32kHz, 44.1kHz, 48kHz, & 96kHz (Using Onboard Clock)
Output Sample Width:	24 bit
<b>Output</b>	
Headphone Output Load:	>45Ω, recommended 400
Maximum Output (Analogue):	+26dBu balanced into 2k or greater
<b>Rear Panel Switches</b>	
Phantom Power:	+48V individual per mic input
Gain Switch:	+10dB per XLR balanced mono & stereo input & EXT 1, EXT 2 inputs
<b>Input &amp; Output Connections</b>	
Analogue Inputs:	5 x Microphone XLR 3 pin sockets 2 x Mono line XLR 3 pin sockets 2 x Mono/stereo line combi XLR 3 pin sockets & 6.35mm stereo jack sockets 1 x Telco XLR 3 pin socket 5 x Stereo line pairs XLR 3 pin sockets 2 x Stereo line pairs phono sockets 1 x Stereo cleanfeed pair XLR 3 pin sockets 1 x Stereo insert, 3.5mm jack socket
Digital Inputs:	2 x S/PDIF phono sockets, 2 x TosLink optical connectors
Analogue Outputs:	2 x XLR 3 pin plug (balanced) AUX: 9-way 'D'-type socket (balanced) TELCO: XLR 3 pin plug (balanced) STEREO CLEANFD: 2 x XLR 3 pin plug (balanced)

Monitor Outputs:	6.35mm stereo jack sockets (2 x Presenter, 1 x Guest, 1 x Monitor)
Digital Outputs:	AES/EBU XLR 3 pin plug (balanced) or S/PDIF phono socket.
Digital Sync Inputs:	Wordclock on BNC, AES/EBU on XLR socket and S/PDIF on phono socket.
EXT Inputs:	9-way 'D'-type socket
Mono Remotes:	25-way 'D'-type plug
Stereo Remotes:	25-way 'D'-type plug
Meterbridge Port:	15-way 'D'-type socket
Talkback Interface:	9-way 'D'-type socket
RS232 Serial Port:	9-way 'D'-type socket
Mains Input:	Filtered IEC, continuously rated 85-264VAC, 47-63Hz, 45w nominal, 50w peak
Fuse Rating:	Anti-surge fuse 2A 20 x 5mm
<b>Equipment Type</b>	
S1:	S1 radio broadcast mixer
<b>Physical Specification</b>	
Dimensions (Raw):	44.5cm (W) x 40.0cm (D) x 15.6cm (H) 17.5" (W) x 15.75" (D) x 6.1" (H)
Dimensions (Boxed):	62cm (W) x 58cm (D) x 36cm (H) 24.40" (W) x 22.83" (D) x 14.17" (H)
Cut-Out Dimensions:	44.0cm, 17.3" (W) x 38.1cm, 15" (D) both dims +0.2cm, -0cm
Weight:	Nett: 12.0kg Gross: 13.6kg Nett: 26.4lb Gross: 29.9lb
<b>Accessories</b>	
S1-RCK:	Optional S1 9U rack ears.

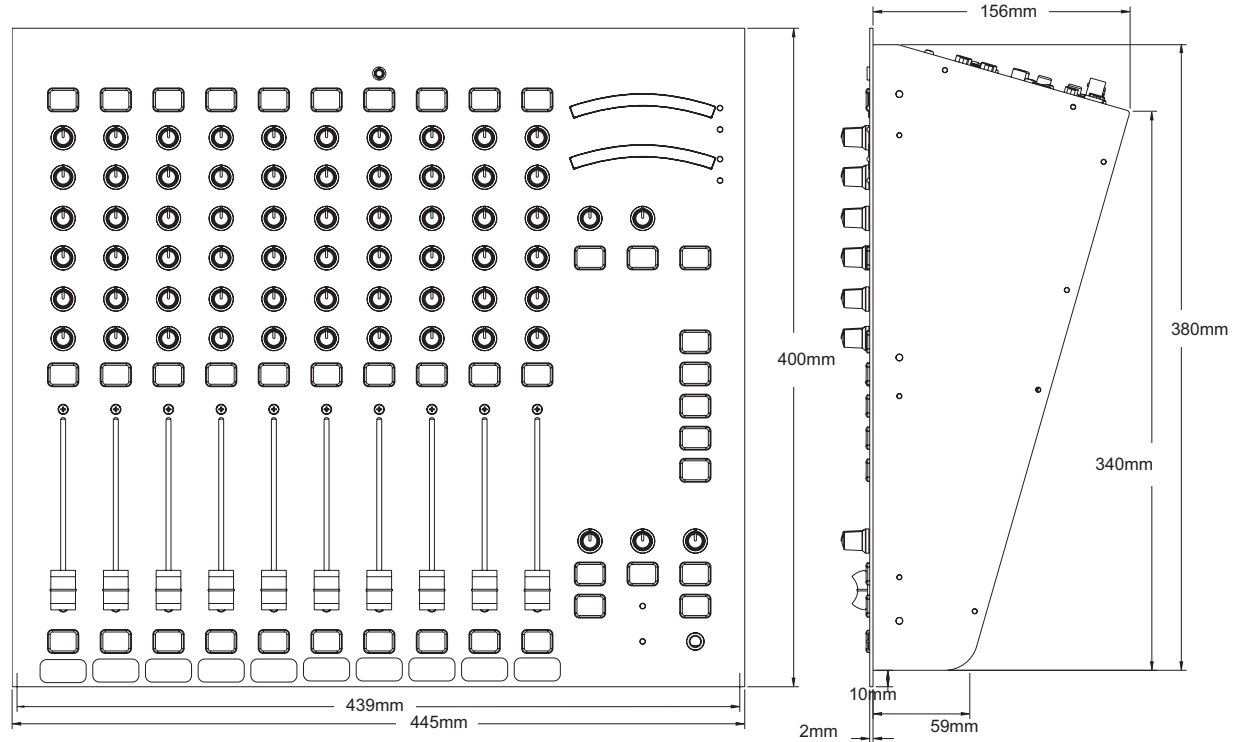

S1 Digital/Analogue Radio Broadcast Mixer Dimensions.



## S2 Digital I/O Analogue Radio Broadcast Mixer



**Category:** Radio Broadcast Mixing Consoles - S2 Digital I/O Analogue Radio Broadcast Mixer.

**Product Function:** Modular multi-channel analogue on-air broadcast mixer with digital I/O.

**Typical Applications:** Community, student, hospital and small scale radio broadcast mixer, secondary or backup on-air mixer.

**Features:**

- Wide range of input and output channels.
- PFL/cue buttons & bus.
- Fader-start operation of equipment.
- Automatic monitor muting on mic-live.
- Light controlling remote outputs.
- Optional EQ on input modules.
- Gram amp input options.
- 2 main audio buses, allowing you to broadcast on the PRG bus while recording on the AUD bus.
- Bus output selection on each module.
- Separate 1U power supply.

S2 is a modular broadcast mixer which offers digital audio quality with analogue reliability in a modular format. S2 has both digital and analogue input channels, together with simultaneous analogue and digital outputs.

Following on from the Sovereign range of audio mixers, S2 combines all the features needed of a radio broadcast mixer in a stylish, flush-mounting chassis

### Innovative Design

- The S2 chassis is available in 5 module width sections, allowing 5, 10, 15, 20, 25 and 30 module width mixers. This means S2 can be used for small newsrooms or large on-air situations.
- Modular “pop-up” input and output channels means that the mixer can be maintained simply and quickly. Hot-swappable input channels can be individually removed and repaired whilst still on-air.

- The angle of the meterbridge can be varied and set for best viewing position.
- Any module can be in any position so that customising the mixer for your own purposes is easy.
- Large back-lit buttons allow you to see the status of the mixer at all times.
- The fitted rear panel hides all cable connections but can be simply unclipped and reclipped for maintenance.
- The modular design of the desk gives you the flexibility to expand it at a later date
- You can even add another S2 mixer and link them together with a bus connector cable to allow for split desk configurations.



*Radio Broadcast Mixer Using S2-25 Chassis and Script Space.*



### Superb Audio Quality and Unquestionable Reliability

- The S2 uses Crystal semiconductor parts to allow input and output of digital audio signals up to 24 bit, 96kHz sample rate.
- The analogue signal paths use low noise circuitry to provide superb audio performance well capable of satisfying radio listeners worldwide.
- The high reliability and build quality of S2 minimises the chance of failure, avoiding lost air-time. Each module is individually checked twice before being assembled into the finished chassis and the whole unit is tested before shipping.
- ALPS long throw 100mm faders give a smooth, repeatable response and the XLR Neutrik connectors used are an industry standard.
- The use of VCAs controlled by the faders ensures tight stereo tracking and eliminates mechanical and electronic noise.
- S2 has a separate 1U power supply providing regulated, ripple-free power to the mixer. There is an optional switcher to control 2 power supplies providing redundancy.
- High quality stainless steel is used for the chassis and screws to prevent corrosion in high humidity environments.
- Each channel is metal coated internally to provide exceptional EMC screening.

## S2 Input Channels

There is a wide choice of input channels for the S2 mixer. Each channel has a number of common features:

### Assigning an Input Channel to an Output Bus

Switches at the top of the channel are used to select the output group routing, to either Program, Audition, or both output buses. Selecting the PGM and/or AUD buttons routes the channel audio to the PGM and/or AUD mix buses. The buttons illuminate green to indicate the routing status.

### Changing the Input Level

Coarse gain is set using pre-set potentiometers on the channel circuit board which allow unbalanced inputs to be used on mono and stereo line inputs. The front panel TRIM control allows fine gain of  $\pm 12\text{dB}$ .

### Changing the Signal Pan, or Balance

The BAL/PAN control is used on mono channels to pan the mono input signal in the stereo image and on stereo channels to balance the stereo image.

### CUE/PFL (Pre Fade Listen)

Selecting the CUE/PFL button routes the pre-fader input signal to the monitoring system where the signal can be heard via headphones and/or loudspeakers. The button lights green when CUE/PFL is active

and a jumper option is available to cancel the CUE/PFL selection when the fader is raised. This button works with both a momentary and latched operation - if held down, the selection is cancelled on release, otherwise the button is alternate action.

### Fader Start & ON Button Control

The ON button works in conjunction with the 100mm long-throw carbon fader and is used to control channel remotes (e.g. starting a CD player), routing and timers, etc. When unlit, the channel is off. Flashing red indicates that the channel has been selected to ON but not routed to either PGM or AUD. Steady red indicates that the channel is ON and "armed", ready for the fader to be raised. Raising the fader changes the illumination to green indicating that the channel is live. Alternatively, with the button unlit the fader may be raised and the channel can be operated simply by selecting ON. The illumination in this case toggles between unlit (channel OFF) and green (channel ON).

### Programmable Button Settings

To make the S2 modules as flexible as possible, every button on each channel can be set to a number of different modes to aid the use of the mixer and allow for extra functionality. Each button can be set to

either operate manually, be permanently on, or permanently disabled. Also, the ON button can be configured to operate in a number of modes, altering remote start functions, and the channel ON function can be controlled remotely by automation playout systems, such as RCS® or VCS.

### Scribble Pad

A scribble pad is provided at the bottom of the channel for user labelling of the channel function.

*RCS® is a registered trademark of Radio Computer Systems Inc.*

*VCS is a wholly-owned subsidiary of SciSys plc.*



## S2-CMM Mic/Mic Channel

The mic/mic input channel is a dual mono microphone input with a button switch to select either Mic 1 or Mic 2.

Each Mic input has jumper settable phantom power available at +48V and a high pass filter to remove low frequency rumbles. When enabled, the LF response of the microphone is rolled off at 125kHz, 6dB per octave. If the Mic input is used for the presenter's mic it can also become the talkback mic.

Equalisation is fitted as standard on this channel and is enabled by the EQ button, S2-CMM Mic/Mic Channel.

providing 10dB cut and boost at HF (6.5kHz) and LF (100Hz).

The BAL/PAN control operates as follows: Full anti-clockwise pans the signal to the left and increases the signal by 3dB (right channel reduces by 70dB); full clockwise pans the signal to the right and increases the signal by 3dB (left channel reduces by 70dB).

A balanced line level insert send and return is available for the Mic input.

This is useful for hooking up an outboard effects unit to be used with the microphone.

There are logic remote input controls for Mic Cough muting and Reverse Talkback, together with 2 separate output controls for Mic Cue lights, momentary or latching.

The remote outputs on the 9 way D-type plug are fed from NPN opto-isolators.

Both Mic inputs have a jumper selectable output to facilitate either Control Room speaker or Studio speaker muting and the channel can also be used to control either one of two separate timer displays.

Gold plated Neutrik XLR connectors are used for the audio inputs and outputs.

## S2-CML Mic/Line Channel

The mic/line input channel is a mono input with a button switch to select either Mic or Mono Line.

For the Mic input, phantom power at +48V can be configured. The Mic input has a jumper selectable high pass filter to remove low frequency rumbles.

If the Mic input is used for the presenter's mic it can also become the talkback mic. The talkback function will be retained when the channel input is switched to Line.



S2-CMM Mic/Mic Rear.

S2-CML Mic/Line Channel Rear.



S2-CML Mic/Line Channel.

## S2-CS Dual Stereo Line Channel & S2-CSE Dual Stereo Line Channel with EQ

The S2-CS dual stereo line channel has two balanced stereo inputs on Neutrik XLR connectors.

The INP 1/INP 2 button selects which input is routed through the channel. The button is illuminated in red to indicate when Input 2 is selected. The operation of the button is inhibited when the channel is "live".

Equalisation is fitted as standard on this channel and is enabled by the EQ button, providing 10dB cut and boost at HF (6.5kHz) and LF (100Hz).

A balanced line level insert send and return is available for the Mic input for the insertion of an effects, or voice, processor into the mic channel. The send and return is disabled in Line mode. There are logic

remote input controls for Mic Cough muting and Reverse Talkback. There are output controls for Mic Cue lights and separate line remote start/stop controls by fader or ON button. Both latching and momentary contacts are catered for. The remote outputs on the 9 way D-type plug are fed from NPN opto-isolators.

The Mic input provides a jumper selectable

output to facilitate either Control Room speaker or Studio speaker muting and the channel can also be used to control either one of two separate timer displays.

In addition the Line input can be configured with all the features of the Mic input when used as a Mic input with an external microphone amplifier, e.g. for monitor muting purposes.

Gold plated Neutrik XLR connectors are used for the audio inputs and outputs.

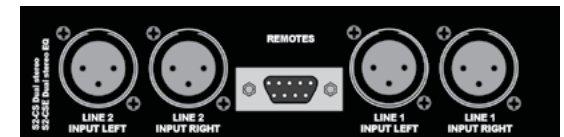
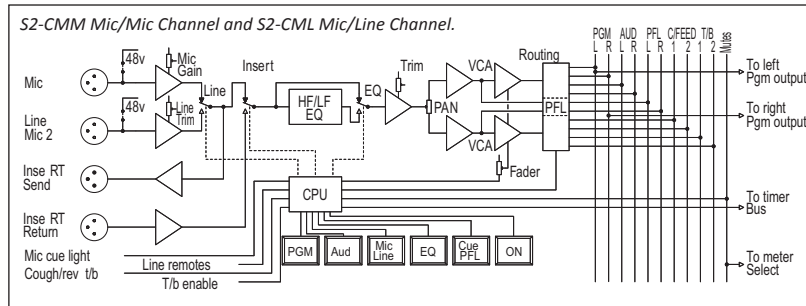

S2-CS Dual Stereo Line and S2-CSE Dual Stereo Line with EQ Rear.



S2-CS Dual Stereo Line Channel.



S2-CSE Dual Stereo Line Channel.

There are separate logic remote output controls for both of the two inputs providing start/stop functions by fader, or ON button. Remotes, etc, are triggered when the fader is up and the channel ON button shows green. The start function can be configured to be either momentary (500mS) or latched for each input. The remote outputs on the 9 way D-type plug are fed from NPN opto-isolators.

Continuous momentary start can be enabled such that when the fader is up and the channel is on, each press of the ON button triggers a momentary start.

Two remote pins can also be configured for general use as either inputs, outputs, latching, or momentary and active high or low. Uses for this include channel live indication or specific channel function remote control.

The BAL/PAN control adjusts the stereo balance in the following manner : Full anti-

clockwise shifts the signal to the left and increases the signal by 6dB (right channel reduces by 6dB); full clockwise shifts the signal to the right and increases the signal by 6dB (left channel reduces by 6dB).

The 100mm VCA fader provides unity gain when fully open. The channel input signal is routed to the outputs whenever the fader is open, the ON button is selected and either or both of the routing buttons are selected.

The S2-CSE channel is the dual stereo line channel as above but fitted with equalisation, providing 10dB cut and boost at HF (6.5kHz) and LF (100Hz).

The EQ button places the equalisation in and out of the signal path. The button is illuminated in yellow when the EQ is active.

The channel can be used to control either one of two separate timer displays.

## S2-CSG Stereo Line & Gram Channel & S2-CSGE Stereo Line & Gram Channel with EQ

The S2-CSG channel is the dual stereo line channel fitted with an RIAA input amplifier on the second input. The balanced stereo line input is on Neutrik XLR connectors and the unbalanced RIAA stereo input on phono.

The channel is used for connecting a turntable or record deck. The GRAM inputs have RIAA equalisation suitable for magnetic pick-up cartridges.

Selecting the LINE/GRAM button switches the channel input between Stereo Line and RIAA . The button is illuminated in red to indicate when Gram (RIAA) is selected. The operation of the button is inhibited when the channel is "live".

There are separate logic remote output controls for both of the two inputs providing start/stop functions by fader, or ON button. Remotes, etc, are triggered when the fader is up and the channel ON

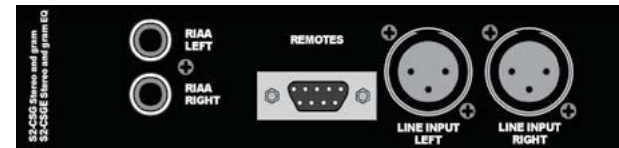

S2-CSG Stereo Line & Gram and S2-CSGE Stereo Line & Gram with EQ Rear.



S2-CSG Stereo Line & Gram Channel.



S2-CSGE Stereo Line & Gram Channel with EQ.

button shows green. The start function can be configured to be either momentary (500ms) or latched for each input. The remote outputs on the 9 way D-type plug are fed from NPN opto-isolators.

Continuous momentary start can be enabled such that when the fader is up and the channel is on, each press of the ON button triggers a momentary start.

Two remote pins can also be configured for general use as either inputs, outputs, latching, or momentary and active high or low. Uses for this include channel live indication or specific channel function remote control.

The BAL/PAN control adjusts the stereo balance in the following manner : Full anti-clockwise shifts the signal to the left and

increases the signal by 6dB (right channel reduces by 6dB); full clockwise shifts the signal to the right and increases the signal by 6dB (left channel reduces by 6dB).

The 100mm VCA fader provides unity gain when fully open. The channel input signal is routed to the outputs whenever the fader is open, the ON button is selected and either or both of the routing buttons are selected.

The S2-CSGE channel is the stereo line & gram channel as above but fitted with equalisation, providing 10dB cut and boost at HF (6.5kHz) and LF (100Hz). The EQ button places the equalisation in and out of the signal path. The button is illuminated in yellow when the EQ is active.

The channel can be used to control either one of two separate timer displays.

## S2-CDS Digital Dual Stereo Channel

The digital dual stereo channel has two 24-bit 96kHz digital inputs with an INP 1/INP 2 button switch to select between them.

The button is illuminated in red to indicate when Input 2 is selected. The operation of the button is inhibited when the channel is “live”.

Either input can be configured to be balanced AES/EBU on standard XLR, or S/PDIF on phono sockets, selected by internal jumpers.

An additional jumper option can be used to decode emphasis when indicated by certain status bits in the incoming data stream.

The digital signals are converted to analogue and from this point the channel functions are the same as the S2-CS Dual Stereo Line channel with the addition that when the ON button flashes green, it means that there is no valid digital input.

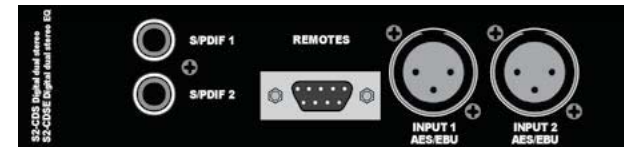

S2-CDS Digital Dual Stereo Channel and S2-CDE Digital Dual Stereo Channel with EQ and Rear.Rear.



S2-CDS Digital Dual Stereo Channel.



S2-CDE Digital Dual Stereo Channel with EQ.



## S2-CDSE Digital Dual Stereo Channel with EQ

This channel is as the digital dual stereo channel but fitted with equalisation.

The HF and LF controls are used to adjust the equalisation of the signal. The HF control boosts and cuts the signal by 10dB at 6.5kHz. The LF control boosts and cuts the signal by 10dB at 100Hz. The EQ button places the equalisation in and out of the signal path and is illuminated yellow when the EQ is active.

Both S2-CDS and S2-CDSE channels can be used to control either one of two separate timer displays.

## S2-CDAS Dual Stereo Line Channel & S2-CDASE Dual Stereo Line Channel with EQ

The S2-CDAS dual stereo line channel has one 24-bit 96kHz AES/EBU digital input and one balanced analogue stereo input, both on Neutrik XLR connectors.

The INP 1/INP 2 button selects which input is routed through the channel. The button is illuminated in red to indicate when Input 2 the balanced analogue source is selected. The operation of the button is inhibited when the channel is “live”.

Input 1 is configured to be the AES/EBU input on standard XLR. An additional jumper option can be used to decode emphasis when indicated by certain status bits in the incoming data stream.

The digital signals are converted to analogue and from this point the channel functions are the same as the S2-CS Dual Stereo Line channel with the addition that when Input 1 is selected and the ON button flashes green, it means that there is no valid digital input signal being received.

There are separate logic remote output controls for both of the two inputs providing start/stop functions by fader, or ON button. Remotes, etc, are triggered when the fader is up and the channel ON button shows green. The start function can be configured to be either momentary (500mS) or latched

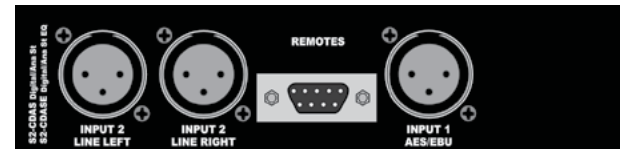

S2-CDAS Dual Stereo Line Channel and S2-CDASE Dual Stereo Line Channel with EQ Rear.

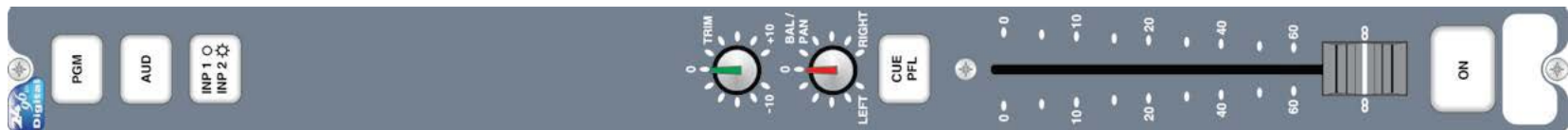

S2-CDAS Dual Stereo Line Channel.

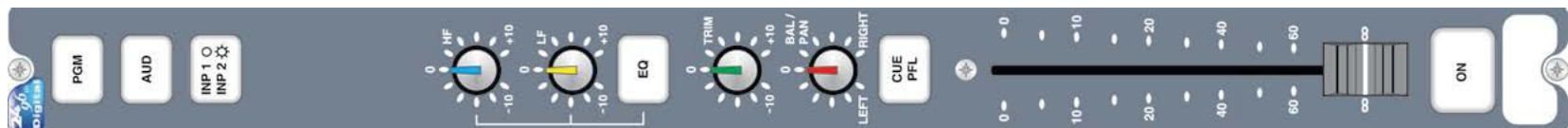

S2-CDASE Dual Stereo Line Channel with EQ.

## S2-C6SS 6 Way Stereo Source Select Channel with EQ

for each input. The remote outputs on the 9 way D-type plug are fed from NPN opto-isolators.

Continuous momentary start can be enabled such that when the fader is up and the channel is on, each press of the ON button triggers a momentary start.

Two remote pins can also be configured for general use as either inputs, outputs, latching, or momentary and active high or low. Uses for this include channel live indication or specific channel function remote control.

The BAL/PAN control adjusts the stereo balance in the following manner : Full anti-clockwise shifts the signal to the left and increases the signal by 6dB (right channel reduces by 6dB); full clockwise shifts the

signal to the right and increases the signal by 6dB (left channel reduces by 6dB).

The 100mm VCA fader provides unity gain when fully open. The channel input signal is routed to the outputs whenever the fader is open, the ON button is selected and either or both of the routing buttons are selected.

The S2-CDASE channel is the dual stereo line channel as above but fitted with equalisation, providing 10dB cut and boost at HF (6.5kHz) and LF (100Hz).

The EQ button places the equalisation in and out of the signal path. The button is illuminated in yellow when the EQ is active.

The channel can be used to control either one of two separate timer displays.

The 6 way stereo line source select channel has 6 balanced stereo inputs on a 25 way D-type connector selectable by a 6 way mechanical interlocking switch bank, numbered 1 - 6. A depressed button indicates the selected input.

The switch bank also controls 6 sets of remote outputs allowing each source to have a set of start/stop remotes. The remote starts can be set as momentary or latching. Continuous momentary start can also be enabled such that when the fader is up and the channel is on, each press of the ON button triggers a momentary start.

The channel is fitted with EQ as standard and other functions are similar to the S2-CSE Dual Stereo channel with EQ.

The HF and LF controls are used to adjust the equalisation of the signal. The HF control boosts and cuts the signal by 10dB at 6.5kHz. The LF control boosts and cuts the signal by 10dB at 100Hz. The EQ button places the equalisation in and out of the signal path and is illuminated yellow when the EQ is active. The channel can be used to control either one of two separate timer displays.



S2-C6SS 6 Way Stereo Source Select Channel With EQ.



S2-C6SS 6 Way Stereo Source Select Channel With EQ and Rear.

## S2-CSMM Stereo Mix Minus Channel

The stereo mix-minus channel has one balanced stereo line level input and a balanced stereo mix-minus output, on XLR connectors. The channel is intended for use where a remote stereo source, such as another studio connected via ISDN, requires a stereo cleanfeed return. The cleanfeed is generated by the mix-minus method from either the PGM or AUD outputs, depending on the routing selection.

Selecting the CUE/PFL & T/B button routes the pre-fader input signal to the monitoring system where the signal can be heard via headphones and/or loudspeakers.

In addition, talkback is routed to the cleanfeed output. This enables the presenter/technical operator to communicate with the remote source prior to going live to air. PFL can be automatically disabled when the fader is opened.

The outputs on this channel can be configured by jumper settings as a mono sum of mix-minus on the left channel and continuous talkback on the right channel (for some ISDN codecs and hybrid applications).

The fader, or ON button, control a logic remote output function. The remote

function can be configured to be either momentary or latched. The remote outputs on the 9 way D-type plug are fed from NPN opto-isolators.

Continuous momentary start can be enabled such that when the fader is up and the channel is on, each press of the ON button triggers a momentary start.

Two remote pins can also be configured for general use as either inputs, outputs, latching, or momentary and active high or low. Uses for this include channel live indication or specific channel function remote control.

Selecting the PGM and/or AUD buttons routes the channel audio output to the PGM and/or AUD mix buses. Selecting the PGM button also routes the PGM main output via the mix minus system to the cleanfeed output. Selecting the AUD button routes the AUD main output to the mix minus system. The mix minus is derived from the PGM output when selecting both PGM and AUD.

Equalisation is fitted as standard on this channel and operates in the same way as on the S2-CSE channel.

The channel can be used to control either one of two separate timer displays.



S2-CSMM Stereo Mix Minus Channel Rear.



S2-CSMM Stereo Mix Minus Channel.

## S2-CT Telco Channel

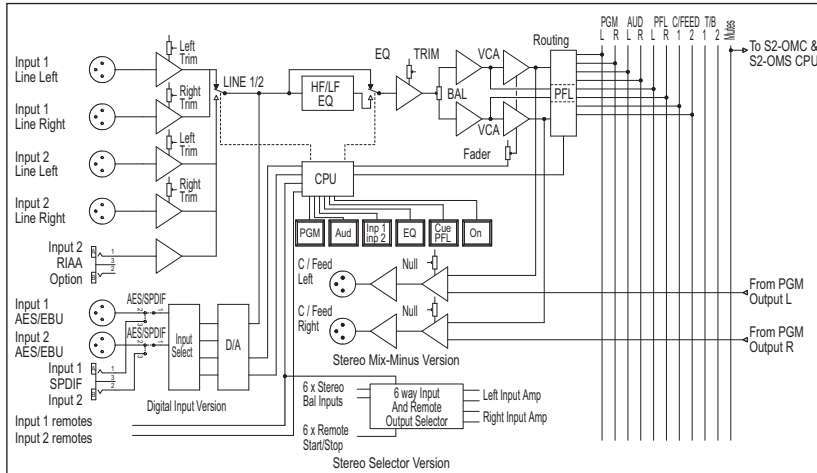

S2-CSG Stereo Line With Gram (S2-CSGE with EQ), S2-CS Dual Stereo (S2-CSE with EQ), S2-CDS Digital Dual Stereo (S2-CDSE with EQ), S2-CSMM Stereo Mix Minus and S2-C6SS Stereo Source Select.

The telco input channel controls the connection to a telephone balance unit (or hybrid). It has one balanced line level mono input on Neutrik XLR, and one balanced line level cleanfeed output to the hybrid.

Selecting the CUE/PFL & T/B button routes the pre-fader input signal to the monitoring system where the signal can be heard via headphones and/or loudspeakers. In addition, talkback is automatically routed back to the caller via the cleanfeed system. This enables the presenter, or technical operator, to communicate with the caller prior to putting the caller live to air. PFL can

be automatically disabled when the fader is opened.

There is a logic remote output to place the hybrid "on hold" by using the LINE HOLD button. The remote output on the 9 way D-type plug is fed from an NPN opto-isolator and it can be made momentary or latching.

Selecting the PGM and/or AUD buttons routes the channel audio output to the PGM and/or AUD mix buses. The buttons are illuminated in green to indicate the routing status. Changing the status of the PGM button is inhibited when the channel is "live".

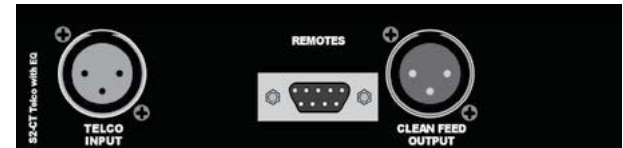

S2-CT Telco Input Channel Rear.



S2-CT Telco Input Channel.

Selecting the PGM button also routes the channel to one of the two true cleanfeed buses (jumper selectable). When selecting only the AUD button, for example to record off-line telephone conversations, a cleanfeed is generated via the channel mix-minus system. When both PGM and AUD are selected the channel operates in

the true cleanfeed mode, sending the PGM signal to the cleanfeed bus.

Equalisation is fitted as standard and is enabled by the EQ button, providing 10dB cut and boost at HF (6.5kHz) and LF (100Hz). The EQ button places the equalisation in and out of the signal path and is illuminated yellow when the EQ is active.

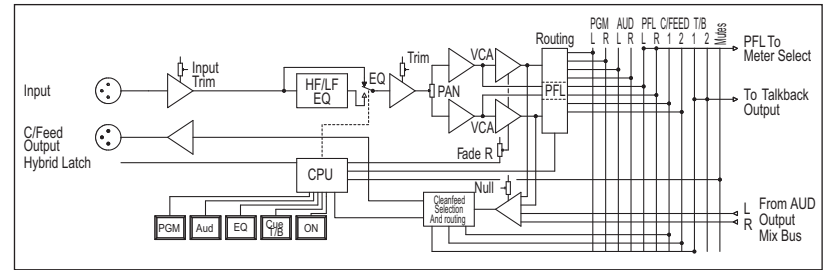

S2-CT Telco Input Channel.

## S2-CB Blank Channel

This blank channel is used to fill in areas of the mixer where you don't require an input or output channel.





## S2 Output Channels

There are six different output channels available, for controlling monitoring in both a Control Room and separate Studio, with the two main output channels also having a master fader option.

The master output channels provide balanced analogue audio outputs as well as simultaneous AES/EBU or S/PDIF digital audio outputs for both PRG and AUD buses. The analogue mono output can be selected from PRG or AUD and meter selection is available to show either the PRG bus, AUD

bus, or to follow the Control Room Monitor selection.

Both Control Room and Studio Monitor channels are available for controlling what's routed to the presenter's and guest's headphones and monitor speakers. 2 external inputs can also be monitored.

A minimum of 3 channels need to be fitted into a mixer: channels S2-OMC, S2-ODP (or S2-ODPF) and S2-ODA (or S2-ODAF) must be fitted and S2-OMS is optional.

## S2-OMC Control Room Monitor Channel

The control room monitor channel is common to every mixer and is used for the monitoring of various sources on the control room loudspeakers (MONITOR) on a 6.35mm stereo jack socket and presenter's headphones (PHONES) on 6.35mm stereo jack sockets. Front panel control knobs are used to vary the monitor and headphone levels and headphones can be plugged in on the front or the rear of this channel. The control room monitor loudspeaker and headphone levels are variable between 0 (cut off) and 10 (max).

A four way electronically interlocking switch bank selects the source routed to the speakers and headphones from either of two external inputs (EXT 1, EXT 2), the PGM, or AUD output. The buttons illuminate to show the selected source, PGM and AUD in green, EXT 1 and EXT 2 in red. The external inputs can be used for monitoring an off air signal or another studio output.

An illuminated Mute LED shows when a live microphone channel in the control room has muted the speakers, to prevent feedback. Mute outputs on the remote connector of

the PGM output channel can be used to remotely illuminate "Mic Live" lights.

AUTO CUE/PFL buttons adjacent to each level control allow the monitoring of PFL when an input channel has been selected to CUE/PFL. In addition, SPLIT CUE/PFL can be selected to the headphones, which will place the selected source in mono in one ear and PFL in mono in the other.

This channel controls the signal conditioning for the talkback input and output and routes these signals to and from the talkback bus.



S2-OMC Control Room Monitor Rear.



S2-OMC Control Room Monitor Channel.

Internal jumpers can be configured to allow talkback to replace or dim the selected source, dimming independently on monitor speakers or headphones.

A Global Talkback system can be configured to allow every contribution point in the control room and studio to communicate with each other via their microphone and headphones.

## S2-OMS Studio Monitor Channel

The studio monitor channel is optional and is used for the monitoring of various sources on the studio loudspeakers (MONITOR) on a 6.35mm stereo jack socket and studio headphones (PHONES) on a 6.35mm stereo jack socket.

A front panel control is used to vary the monitor level. The studio monitor loudspeaker level can be variable between 0 (cut off) and 10 (max). The output will need to be fed to a suitable power amplifier to drive the loudspeakers. Headphones

with impedances of 35Ω and above can be driven directly from the channel headphone connector on the rear panel.

A four way electronically interlocking switch bank selects the source routed to the speakers and headphones from either of two external inputs (EXT 1, EXT 2), the PGM, or AUD output. The buttons illuminate to show the selected source, PGM and AUD in green, EXT 1 and EXT 2 in red. External inputs can be used for monitoring an off air signal or another studio output.

An illuminated Mute LED shows when a live microphone channel in the studio has muted the speakers. Mute outputs on the remote connector of the AUD output channel can be used to remotely illuminate "Mic Live" lights.

Green illuminated AUTO CUE/PFL buttons adjacent to each level control allow the monitoring of PFL when an input channel has been selected to CUE/PFL, either to the monitors or headphones.

A separate Studio T/B button is provided to allow the presenter/engineer to talk to the studio monitors and/or headphones and internal jumpers allow this talkback to replace or dim the selected source.

A Global Talkback system can be configured to allow every contribution point in the control room and studio to communicate with each other via their microphone and headphones.

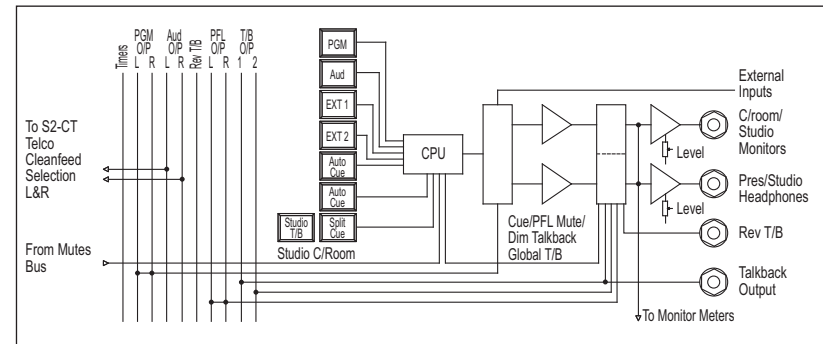

S2-OMS Studio Monitor Channel and S2-OMC Control Room Monitor Channel.



S2-OMS Studio Monitor Rear.



S2-OMS Studio Monitor Channel.

## S2-ODP Digital PGM Output Channel & S2-ODPF Digital PGM Output Channel with Master Fader

This channel is common to every mixer and provides a digital and analogue output from the PGM mix bus. The digital output is available as a balanced AES/EBU signal via a standard XLR or as S/PDIF on phono sockets. The balanced analogue PGM output and mono output is on a 15 way D-type connector. This also carries the two sets of latching relay contacts for the control room mutes.

The main power input from the S2-PSU is on this channel. Button switches at the top of the channel select the mono output source from either PGM or AUD. The Mono compatible output could be used to feed a mono transmitter or any station output monitoring system that requires a mono signal, such as a background music system.

The digital output status bits (consumer or professional), output sample size (16, 20 or 24 bits) and sample rate (automatically or by internal jumpers from 32 kHz to 96 kHz) can be set. The digital output can be synchronised from an external input, or

from an on-board master clock. There are 4 different sync modes : Master, Auto, Auto Lock and Slave.

The illuminated LOCK LED shows that the digital output is locked to the onboard master clock, incoming word clock or AES/EBU or S/PDIF sync signal. The channel automatically locks to a valid sync clock, flashing if sync is lost. Synchronisation can be jumper disabled.

The S2-ODPF channel also has a 100mm VCA output fader for production use which provides unity gain when fully open.

S2-ODP Digital PGM Output Channel and S2-ODPF Digital PGM Output with Master Fader.

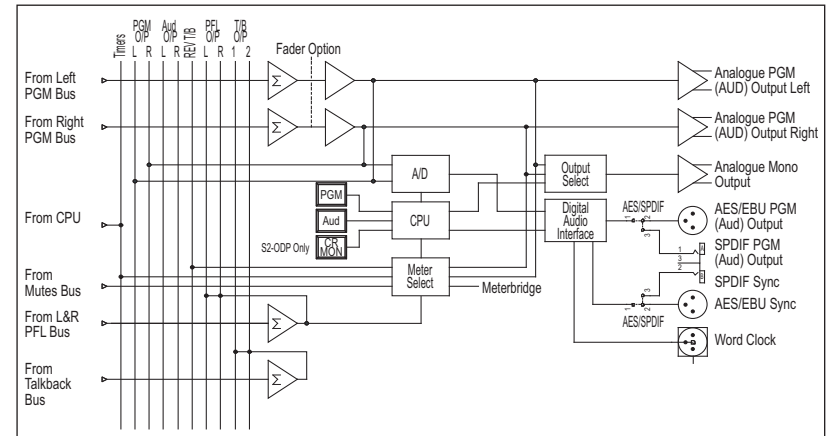
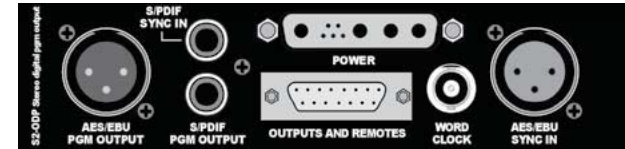

S2-ODP Digital PGM Output Channel (S2-ODPF with Master Fader) and S2-ODA Digital AUD Output Channel (S2-ODAF with Master Fader).



S2-ODP Digital PGM Output Channel.



S2-ODPF Digital PGM Output Channel with Master Fader.

## S2-ODA Digital AUD Output Channel & S2-ODAF Digital AUD Output Channel with Master Fader

This channel is also common to every mixer and provides a digital and analogue output from the AUD mix bus. The digital output is available as a balanced AES/EBU signal via a standard XLR or as S/PDIF on phono sockets. The balanced analogue AUD outputs are available on a 15 way D-type connector which also carries the two sets of latching relay contacts for the studio mutes.

Button switches at the top of the channel select the monitoring source to the meterbridge. Meters in the meterbridge which are connected to the "Monitor Meter" position will display the selected signal from the electronically interlocking PGM, AUD, or CR MON buttons. The CR MON signal source is whatever is being

monitored on the presenter's headphone on the control room monitor channel, pre talkback and level control. This signal could be PGM, AUD, EXT 1, EXT 2, or PFL, as selected by the presenter.

The digital output status bits (consumer or professional), output sample size (16, 20 or 24 bits) and sample rate (automatically or by internal jumpers from 32 kHz to 96 kHz) can be set. The digital output can be synchronised from an external input, or from an on-board master clock. There are 4 different sync modes : Master, Auto, Auto Lock and Slave.

The illuminated LOCK LED shows that the digital output is locked to the onboard master clock, incoming word clock or AES/EBU or S/PDIF compatible sync signal. The

channel automatically searches for a sync signal on the Word Clock, or the selected digital input, and automatically locks to a valid sync clock. If sync is lost then the indicator will flash. Synchronisation can be jumper disabled.

The S2-ODAF channel also has a 100mm VCA output fader for production use which provides unity gain when fully open.

## S2-PG Penny & Giles Conductive Plastic Fader



The input and output channels of an S2 mixer can optionally be fitted with high quality Penny & Giles faders.

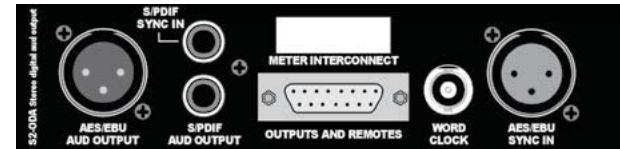

S2-ODA Digital AUD Output Channel and S2-ODAF Digital AUD Output Channel with Master Fader Rear.



S2-ODA Digital AUD Output Channel.



S2-ODAF Digital AUD Output Channel with Master Fader.



## S2 Meterbridge Modules

In the meterbridge area you can choose from four styles of metering, a phase meter, a dual timer, a PFL/Talkback loudspeaker, 2 talkback modules, 3 switch panels and a range of blanking plates. S2's meterbridge modules are freely assignable so that you can position them exactly where you want them.

The dual meter panels are used for monitoring console signal levels. Up to three different meter panels can be housed in the meterbridge. The meters can be configured internally to be fed from one of three signal sources, the selected source indicated by a LED:

**Select** The output of the meter switch on the AUD output module which can show PGM, AUD, or CR MON, which is the selected monitor source on the control room monitor module, (EXT 1, EXT 2, PGM, or AUD) interrupted by PFL.

**Program** PGM output which can optionally be interrupted by PFL.

**PFL** The output of the PFL bus.

## S2 Without Meterbridge

The S2 is available without a meterbridge. This does affect some of the features available on the mixer. Contact sales@sonifex.co.uk for further information and pricing.

In the meterbridge area you can choose from four styles of metering, a phase meter, a dual timer, a PFL/Talkback loudspeaker, 2 talkback modules and a range of blanking plates. S2's meterbridge modules are freely assignable so that you can position them exactly where you want them.

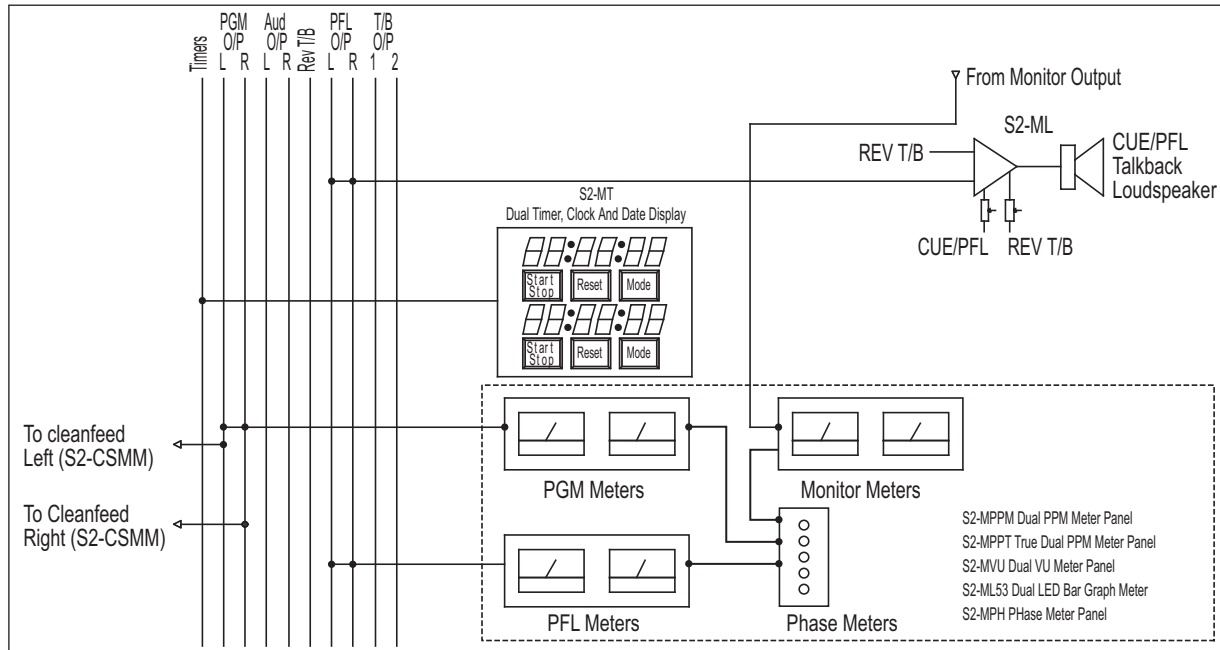

S2-MPPM/T Meterbridge PPM Panel, S2-MVU Meterbridge VU Meter Panel, S2-ML53 Meterbridge LED Meter Panel, S2-MPH Meterbridge Phase Meter Panel, S2-MTBS Station Master and S2-MTB6 6 Way Talkback Panels, S2-MT Meterbridge Dual Timer Panel and S2-ML Meterbridge Loudspeaker Monitor and Talkback Panel.



## S2-MPPM Meterbridge PPM Meter Panel

The S2-MPPM panel has two fast-reading moving-coil meters with PPM-style scale.

The PPMs have a 1-7 scale and are configured such that a 1kHz signal, at 0dB at the PGM output, will indicate a meter reading of 4. Each mark on the PPM scale indicates a 4dB change in signal level.



## S2-MVU Meterbridge VU Meter Panel

The S2-MVU two moving coil VU meters are

configured such that a 1kHz signal, at +4dBu at the PGM output, will indicate a meter reading of 0VU.



## S2-ML53 Meterbridge LED Meter Panel

The LED meter consists of 53 LEDs showing both VU and peak representation. Both PPM and VU scales are shown, one on each side of the LED bar-graph.



## S2-MPH Meterbridge Phase Meter Panel

The S2-MPH is a phase meter which operates on the selected source to the meters. 5 LED indicators show the phase angle in 45 degree steps from 0 (in-phase) to 180 (out of phase).

A separate phase meter can be linked to each meter in the meterbridge.

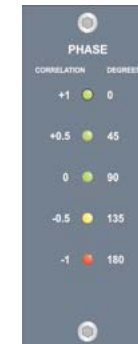

## S2-MT Meterbridge Dual Timer Panel

Each of the dual timers can be used for timing events triggered by Timer 1, Timer 2, or the Mic fader open signal. In addition the upper timer is used for displaying the time of day and the lower timer for displaying the date. The illumination pattern of the red LEDs indicates the timer display mode.

The date and time can be synchronised to a very accurate internal clock or optionally from an external source, MSF, DCF, SMPTE, or RS232 time code string.



## S2-ML Meterbridge Loudspeaker Monitor Panel

The S2-ML speaker is used for monitoring PFL and reverse talkback in the control room directly from the mixer. Two control knobs are provided for adjusting the levels of the PFL and Talkback signals from cut-off at 0 to unity gain at 10. The speaker is muted automatically when the control room mute is active, to prevent feedback.



## S2-MSB1 S2 Meterbridge Switch Panel With 1 Button

This is a meterbridge panel, 1 channel wide, with 1 button which can be used for bespoke control of the S2, or for your own purposes, e.g. equipment control.

Contact Sonifex with your particular mixer control requirements.



## S2-MSB3 S2 Meterbridge Switch Panel With 3 Buttons

This is a meterbridge panel, 1 channel wide, with 3 buttons which can be used for bespoke control of the S2, or for your own purposes, e.g. equipment control linked to an RB-OA3 on-air switcher.

Contact Sonifex with your particular mixer control requirements.



## S2-M6SS Meterbridge 6 Way Source Select Panel

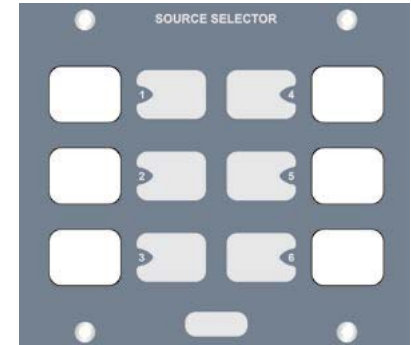

The meterbridge source selector panel produces a stereo analogue audio output from 6 selectable stereo analogue sources, which can be connected to a stereo input channel within the mixer, or the EXT 1 and EXT 2 monitor inputs, to provide up to 12 external monitor inputs. There are 6 illuminated push buttons, which select and indicate the current channel selection. The 6 stereo sources are connected on the rear of the panel via a connector, which uses exactly the same pin configuration as the stereo audio source input connector on the S2-C6SS channel.

## S2-MTBS Meterbridge Station Master Talkback Panel

This is used for interfacing with a Sonifex Station Master studio switcher and talkback router, or the RB-OA3 on-air switcher, and has buttons for talkback, Offer and Accept switching and profanity delay control.



## S2-MTB6 Meterbridge 6 Way Talkback Panel

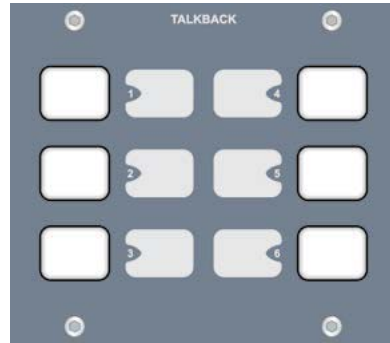

This is used for communicating with up to 6 other locations, studios or mixers, and with the Sonifex TB-6D and TB-6R talkback intercoms. While a button is pressed, the switch is illuminated and the talkback is active. The buttons work with both a momentary and latched operation - if held down, the selection is cancelled on release. Otherwise the button is alternate action.

## Alternative Button Text

For meterbridge panels, the buttons can be supplied with different printed script. A few examples are shown here, but for a full list, please go to the Sonifex website: [www.sonifex.co.uk/s2/s2-buttons.shtml](http://www.sonifex.co.uk/s2/s2-buttons.shtml)



## S2-MB1-5 Meterbridge Blanking Plates 1-5

Meterbridge blanking plates are available in channel widths from 1 to 5 inclusive and are used to fill areas in the meterbridge not occupied by active modules.

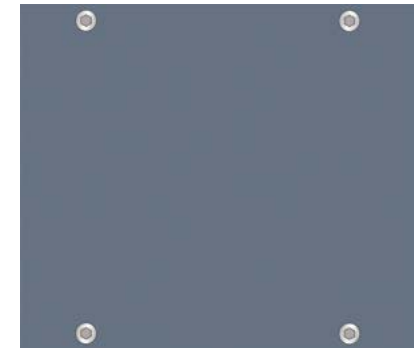



## S2 Chassis Sizes

The S2 chassis is available in 5 channel width sections, allowing 5, 10, 15, 20, 25 and 30 channel width mixers. This means S2 can be used for small newsrooms or large on-air situations.

### Chassis Sizes

Model No.	Number of Channels
S2-05	5
S2-10	10
S2-15	15
S2-20	20
S2-25	25
S2-30	30

### S2-05 Chassis

Chassis with 5 channel width sections.



### S2-15 Chassis

Chassis with 15 channel width sections.



### S2-25 Chassis

Chassis with 25 channel width sections.



### S2-10 Chassis

Chassis with 10 channel width sections.



### S2-20 Chassis

Chassis with 20 channel width sections.



### S2-30 Chassis

Chassis with 30 channel width sections.



## S2-7SS Script Space

The script space occupies an area of 7 channel widths, and is designed to hold documents or scripts for the mixer operator when desk space is at a premium. The S2-7SS Script Space is 266mm wide x 390mm deep.



## S2-10SS Script Space

This script space is 10 channels wide and is large enough for a small keyboard. The S2-10SS Script Space is 380mm wide x 390mm deep.



## S2 Mixer Weights and Boxed Dimensions

Mixer Type	Width (cm)	Width (inches)	Depth (cm)	Depth (inches)	Height (cm)	Height (inches)	Gross Weight (kg)	Gross Weight (lbs)	Nett Weight (kg)	Nett Weight (lbs)
S2-30	137cm	53.9"	70cm	27.6"	45cm	17.7"	36kg	79lbs	32kg	70lbs
S2-25	117cm	46.0"	70cm	27.6"	45cm	17.7"	35kg	77lbs	31kg	68lbs
S2-20	100cm	39.4"	70cm	27.6"	45cm	17.7"	33kg	73lbs	29kg	64lbs
S2-15	80cm	31.5"	70cm	27.6"	45cm	17.7"	27kg	59lbs	24kg	53lbs
S2-10	60cm	23.6"	70cm	27.6"	45cm	17.7"	25kg	55lbs	22kg	48lbs
S2-05	60cm	23.6"	70cm	27.6"	45cm	17.7"	22kg	48lbs	20kg	44lbs

## Technical Specification For S2

Input/Output Impedances	
Mic Input:	> 1k5Ω electronically balanced
Mono Line Input:	> 20kΩ electronically balanced
Stereo Line Input:	> 20kΩ electronically balanced
PGM & AUD Output:	< 75Ω electronically balanced
Mono Output:	< 75Ω electronically balanced
Monitor Outputs:	< 75Ω unbalanced
AES Input/Output:	110Ω
S/PDIF Input/Output:	75Ω
BNC Wordclock input:	50Ω
Input/Output Gain Range	
Mic Input:	Preset pot +13dB to +66dB ref -50dBu, TRIM pot ±12dB
Mono Line Input:	Preset pot -6dB to +10dB ref 0dBu, TRIM pot ±12dB
Stereo Line Input:	Preset pot -6dB to +10dB ref 0dBu, TRIM pot ±12dB
Telco Input:	Preset pot -6dB to +10dB ref 0dBu, TRIM pot ±12dB
Telco Output:	Preset pot -6dB to +4dB ref 0dBu
Mix Minus Input:	Preset pot -6dB to +10dB ref 0dBu, TRIM pot ±12dB
Mix Minus Output:	Preset pot -3dB to +3dB ref 0dBu
Digital Input:	0dBFS = +12dBu on input; TRIM pot ±12dB allowing 0dBu to +24dBu
Digital Output:	0dBFS = +18dBu
Frequency Response	
Mic Input:	40Hz to 20kHz, -1dB,+0dB (-3dB at 130Hz with HPF in)
Line Inputs:	20Hz to 20kHz, - 0.5dB,+0dB
RIAA Input:	30Hz to 16kHz ±1.5dB RIAA equalised
Noise (20Hz to 20kHz)	
Mic Input E.I.N.:	-129dB with 150Ω source
Stereo Inputs (fader down, no routing):	-89dB ref 0dB
Stereo Inputs (fader down, one channel routed):	-89dB

Stereo Inputs (unity gain, no routing):	-89dB
Stereo Inputs (unity gain, one channel routed):	-86dB
Stereo Inputs (unity gain, two channels routed):	-83dB
Distortion	
Total Harmonic Distortion:	0.015% at 1kHz, 0dB
	0.025% at 10kHz, 0dB
Crosstalk	
Inter-channel:	< -90dBu
Stereo:	-90dBu at 1kHz
Equalisation	
LF Shelving at 100Hz:	±7dB
HF Shelving at 6.5kHz:	±7dB
Range	
Pan Range:	Pot position: Fully clockwise, centre, fully anti-clockwise; Left: Off, 0dB, +3dB; Right: +3dB, 0dB, Off respectively.
Balance Range:	±6dB
Common Mode Rejection Ratio	
Mic Input:	> 100dB at 70dB gain
Digital I/O	
Sync Input Sample Rate:	30kHz - 100kHz
Output Sample Rates (Using Onboard Clock):	32kHz, 44.1kHz, 48kHz, & 96kHz
(Using Sync Input):	30kHz - 100kHz
Output Sample Width:	16, 20, 24 bit
Output	
Headphone Output Load:	>45Ω, 400Ω recommended
Maximum Output (Analogue):	+26dBu balanced into 2kΩ or greater
Power	
Power (S2-PSU):	Filtered IEC, switchable 115V, 230V, fused, 210W max.





## S2 Mixer Placement In Furniture



*Solutions Single Mixer Furniture Package Showing an S2-25 Mixer.*

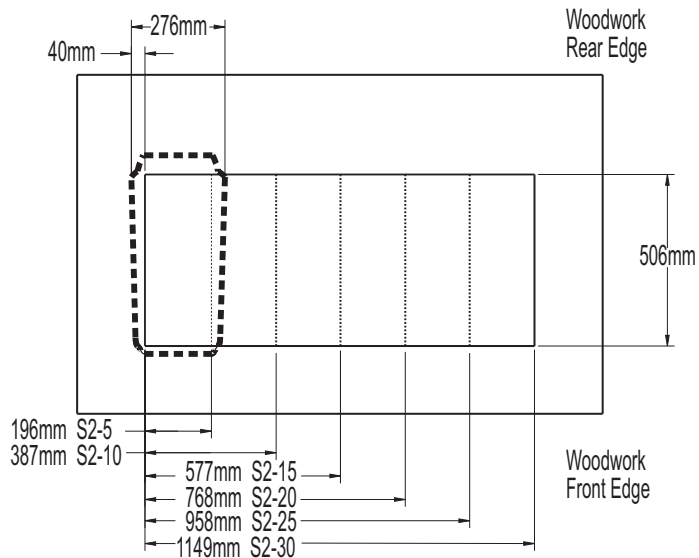

*S2 Placement in Cut-Out Viewed from Above.*

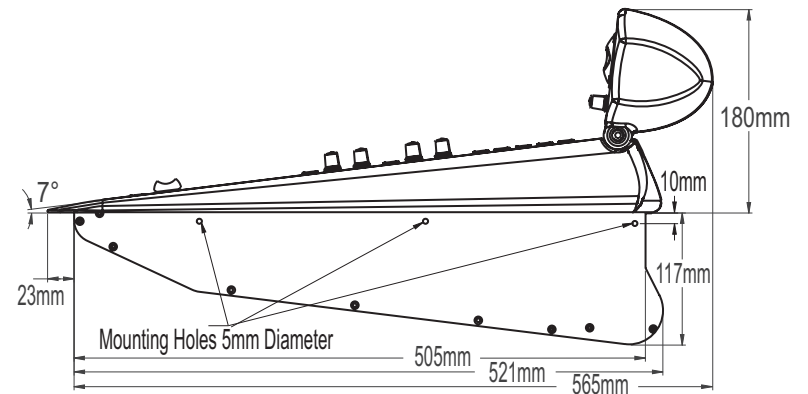

*S2 Mixer Viewed from Side Profile.*



## S2-PSU Power Supply



S2-PSU Front Panel.

The S2-PSU is a 1U high rack-mount unit, which supplies power to the entire range of S2 mixers. A lead with a special 9 pin D-Type socket on each end is used to connect the power supply to the S2-ODP PGM output channel on the mixer.

LEDs on the front of the unit indicate whether the power to the voltage rails is being supplied correctly.

### Dimensions (S2-PSU)

(Raw): 48cm (W) x 24.3cm (D) x 4.4cm (H)  
19" (W) x 10" (D) x 3.5" (H)

(Boxed): 54cm (W) x 41cm (D) x 16cm (H)  
21.3" (W) x 16.1" (D) x 6.3" (H)

### Weight (S2-PSU)

Nett: 6kg Gross: 7.8kg  
Nett: 13.2lbs Gross: 17lbs



S2-PSU Rear Panel.

## S2-BI Bus Interlink Cable

This is used to connect two S2 chassis so that they can function as one mixer. Note that a maximum total of 30 channels is allowed in a split mixer configuration.





## S2-PSUS Dual Power Supply Switcher



S2-PSUS Front Panel.

The S2-PSUS is a passive power switcher which takes the power feeds from 2 x S2-PSU units and switches between them in the event of failure. Two trailing leads 0.5m in length connect to 2 x S2-PSU units. With LED failure indicators and GPI alarms, the S2-PSUS is the perfect dual redundant power supply module.

### Dimensions (S2-PSUS)

(Raw):	48cm (W) x 23cm (D) x 4.4cm (H)
	19" (W) x 9" (D) x 1.7" (H)

(Boxed):	55cm (W) x 39.3cm (D) x 8.5cm (H)
	21.6" (W) x 15.5" (D) x 3.4" (H)

### Weight (S2-PSUS)

Nett:	1.58kg	Gross:	2kg
Nett:	3.5lbs	Gross:	4.4lbs



S2-PSUS Rear Panel.



*Sonifex S2 Solutions Furniture.  
Photo courtesy of Huddersfield Hospital Radio.*





## Radio Studio Packages

Monitor Speaker Stands

208



*Sonifex S2 Solutions Furniture.  
Photo courtesy of Dixie Media.*





## Monitor Speaker Stands



**Category:** Speaker Mounts.

**Product Function:** For desktop mounting monitor speakers.

**Typical Applications:** In any studio (radio, TV, recording, voiceover, production) to mount speakers above the level of the desktop.

**Features:**

- Hard wearing.
- Cable hole for hiding cable.
- Desktop mounting.

### SOL-MS21, SOL-MS32, SOL-MS40, SOL-MS53 Monitor Speaker Stands

Made from steel, the stands are strong and resilient with a black semi-gloss stove enamel coating. The stands are tubular and have a cable hole, surrounded by a black grommet, which sits just underneath the top round plate so that speaker cables can be routed into the tube and hidden inside the tube through to the underside of a work surface. The top plate is round and has 4 countersink holes for screwing into the base of a speaker. The bottom plate has 4 arms each with a straight hole for bolting the speaker stand onto a desktop or similar surface.

The mounts are supplied with M5 screws, washers and nuts for the base and No. 6 x 5/8" wood-screws for the top.

**SOL-MS21** monitor speaker stands, 21cm (8") high, black, pair.

**SOL-MS32** monitor speaker stands, 32cm (13") high, black, pair.

**SOL-MS40** monitor speaker stands, 40cm (16") high.

**SOL-MS53** monitor speaker stands, 53cm (21") high.

### S2 Solutions Monitor Speaker Stands

Stock Code	Description
SOL-MS21	Monitor Speaker Stands, 21cm High, Black, Pair
SOL-MS32	Monitor Speaker Stands, 32cm High, Black, Pair
SOL-MS40	Monitor Speaker Stands, 40cm High, Black, Pair
SOL-MS53	Monitor Speaker Stands, 53cm High, Black, Pair





## Talkback & Commentary

### Talkback Control Unit

The CM-TB8 is a talkback control unit providing 8 channels of 4-wire communication, housed in a 1U rack mount enclosure. There are two options to add PSTN or GSM interfaces.

CM-TB8 8 Channel Talkback Control Unit	210
CM-TB8T Talkback Control Unit, CM-TB8 with CM-TBT Dual PSTN Telephone Hybrid	213
CM-TB8G Talkback Control Unit, CM-TB8 with CM-TBG Dual GSM Interface	214

### Professional Gooseneck Microphone

CM-GM1 Professional Gooseneck Condenser Microphone	215
--	-----

### Commentator Units

There are two commentator units catering for single and dual commentary positions.

CM-CU1 Commentator Unit, 1 Commentator & Line Input	216
CM-CU21 Commentator Unit, 2 Commentators & 1 Guest	220

### Beltpacks

CM-BH4W & X Belt-Pack 4-Wire Headphone Amp	224
CM-BHA Belt Pack Headphone Amplifier With Limiter & Loudspeaker	225

### Talkback

The Sonifex Talkback Intercoms provide a cost effective way of enabling talkback between up to 7 areas in a studio complex.

TB-6D & TB-6R 6 Way Talkback Intercoms	226
--	-----





## CM-TB8 8 Channel Talkback Control Unit



The CM-TB8 is a powerful and highly flexible self contained communications unit allowing multiple 4-wires and IFBs within a single 1U rack space. It offers easy connection to any industry standard talkback system including the Sonifex CM-TLL line listen unit, the CM-BHA and CM-BH4W belt-packs plus the CM-CU1 and CM-CU21 commentator units.

The CM-TB8 8 Channel Talkback Control Unit is ideal in an OB truck or small studio. The CM-TB8 is a talkback control unit providing 8 channels of 4-wire communication, housed in a 1U rack mount enclosure.

The unit has individual connections for both a headset on 5 pin XLR and microphone/



**Category:** Talkback & Commentary.

**Product Function:** Talkback controller offering 8 channels of 4 wire/IFB with options for GSM & POTs comms.

**Typical Applications:** Ideal in an OB van/truck or small production gallery where talkback is needed between up

to 8 different areas/groups, which could be commentators, cameramen, presenters, etc.

### Features:

- 8 Channel talkback control unit in a 1U rack mount package.
- Separate microphone and headset inputs with phantom power and individual gain settings.
- Microphone talk level can be instantly adjusted or preset.
- Talk level LEDs and built-in limiter.
- Configurable 'Group Talk' function.
- Interruptible Foldback and direct 4-Wire operation selectable on each channel with optional talkback-microphone mix function.
- 2 external IFB (Interruptible Foldback) inputs available to each channel.
- Optional telephone hybrid or GSM ports allow direct connection to a telephone line for remote communications.
- Individual monitor level control for each channel.
- Microphone output feed which is gain adjusted & level limited.
- Ethernet connection for remote

configuration with built-in web server.

- 6 stored configuration templates with 4 user editable sets.
- Front panel loudspeaker with separate feed for an external loudspeaker.
- Loudspeaker mute and dim controls, also available on remote input.
- Remote 'tally' outputs indicating when each channel is active.
- Remote inputs providing a call indication on each channel.
- Built in tone generator for channel identification.

headphones on XLR/stereo TRS jack, with the current selection indicated on the front panel. The gain setting for each input type can be individually set between +6dB and +68dB allowing for a wide range of microphone types and +48V phantom power is also available. Small talk level adjustments can be made quickly, using the front panel rotary control with a maximum adjustment range of  $\pm 12$ dB. This adjustment can be disabled if required to stop inadvertent changes. A level limiter automatically adjusts the microphone gain if the signal level exceeds a preset level, and the current talk level is indicated on the front panel when it exceeds 0dB and +8dB. A separate output on the rear panel provides a balanced, gain adjusted and level limited microphone signal on 3 pin XLR.

Each channel can be set to either 4-Wire or Interruptible Foldback operation. In 4-Wire mode the 4-Wire input signal is routed to the monitor channel (headphones/headset & loudspeaker) at the level set by the monitor level potentiometer. When the TALK button is pressed, the microphone signal is routed to the rear panel talkback output connector, and the level of the feed to the loudspeaker is reduced to the level preset by the dim potentiometer.

When in IFB mode, the channel's own 4-Wire input, or one of two external IFB inputs, is routed to the talkback output connector and can be selected as the interruptible signal. It is also possible to configure each channel so that the input

signal is mixed with the microphone input rather than being interrupted by it.

When a channel's TALK button is active, the level of the signal routed to the loudspeaker is automatically reduced by a preset amount, which ranges between full on and off. The TALK button also acts as a call indicator. When the signal level on the 4-Wire input of an inactive channel is above -12dB, the talk button illuminates green. The TALK and GROUP TALK buttons all have a momentary action that will automatically latch on if they are briefly pressed.

The group talk function allows a group of preselected channels to be activated simultaneously. The buttons on all activated channels are illuminated as is the GROUP

TALK button. Each channel can be included or excluded from group talk function, and by default, all channels are included.

Each channel has a separate monitor level control which sets the level of the signal that is mixed with the other active channels. This signal is then fed to both the loudspeaker and headphone monitor channels and its overall level is controlled by the monitor level potentiometer. The loudspeaker has front panel mute and dim attenuation level controls. An external loudspeaker connection on the rear panel provides a level adjusted output and when this output is used, the signal to the internal speaker is muted.

The unit has a built in line-up tone generator for easy channel identification and cabling



CM-TB8 Front View.



CM-TB8 Rear View Showing Optional CM-TB8T Card.

checks. The test-tone generator has 2 modes. In manual mode, tone is routed to a channel when the corresponding TALK button is pressed. In auto mode, a tone pulse is generated on each channel to uniquely identify it.

A rear panel mounted remote output connector provides a 'tally' indication of active talk channels and group talk status via open collector driven outputs. Other 'tally' outputs indicate the status of the loudspeaker dim and mute controls and also if any of the audio input activated call indications are active.

A separate remote input connector provides an additional call input indication on each channel. When an input is activated, the corresponding talk button flashes. Inputs to remotely operate the loudspeaker dim and mute controls are also available.

An optionally fitted telephony add-in card (CM-TB8T or CM-TB8G respectively) allows up to 2 channels to be connected to a telephone or GSM network. This allows the operator and the talkback users to communicate with a connected caller and both 4-wire and IFB operation is available.

The CM-TB8 provides a wide range of user configurable options and there are 6

configuration templates that allow settings to be stored and recalled at a later date. Two of the configuration sets are read only and cannot be changed. The other four can be used to store customised settings. This allows the unit to be preconfigured for a range of user scenarios which can be instantly recalled.

The Ethernet port allows configuration settings to be modified using the built-in web server and an on-board configuration mode allows several of the configuration options to be changed without the need of a PC.

The CM-TB8 talkback control unit is powered from a universal mains input between 85-264V AC at 47-63Hz.



CM-TB8 Home Page.

### Specification For CM-TB8

<b>Microphone Input</b>	
Gain Range:	+6dB to +68dB
Maximum Input Level:	-6dBu
C.M.R.R.:	>60dB
Frequency Response:	±0.5dB 20Hz to 15kHz Ref 50dB gain @ 1kHz
<b>Headphone Output</b>	
Gain Range:	-60dB to +18dB
Maximum Output Level:	+18dBu
Frequency Response:	±0.5dB 20Hz to 15kHz
<b>4-Wire And IFB Inputs</b>	
Maximum Input Level:	+18dBu
Frequency Response:	±1dB 20Hz to 15kHz
<b>Talkback Outputs</b>	
Maximum Output Level:	+18dBu
Frequency Response:	±1dB 20Hz to 15kHz
<b>Loudspeaker</b>	
Power Output:	6W
Noise:	More than 80dB below full output



CM-TB8 Configuration Channels Page.

Volume:	Mute to full volume via front panel potentiometer
<b>Connections</b>	
Microphone:	XLR-3 pin female (electronic balanced)
Headphones:	6.35mm stereo jack socket
Headset:	XLR-5 pin female (input electronic balanced)
4-Wire Inputs:	8 x XLR-3 pin female (transformer balanced)
IFB Inputs:	2 x XLR-3 pin female (transformer balanced)
Talkback Outputs:	8 x XLR-3 pin male (transformer balanced)
Microphone Output:	XLR-3 pin male (electronic balanced)
Loudspeaker Output:	6.35mm stereo jack socket
Remote Inputs:	15-way 'D'-type socket
Remote Outputs:	15-way 'D'-type socket
Ethernet:	RJ-45, 10/100Mbps
Telephone:	4 x RJ11 6/4 (2 x line, 2 x handset), present on CM-TB8T only
Mains Input:	Universal filtered IEC, continuously rated 85-264VAC, 47-63Hz, 25W
Fuse Rating:	Anti-surge fuse 2A 20 x 5mm
<b>Equipment Type</b>	
CM-TB8:	8 channel talkback control unit
CM-TB8T:	Add-in card with 2 x telephone hybrids
CM-TB8G:	Add-in card with 2 x GSM lines
<b>Physical Specification</b>	
Dimensions (Raw)	57cm (W) x 52cm (D) x 15cm (H)
Including Connectors:	22.4" (W) x 20.5" (D) x 5.9" (H) (1U)
Dimensions	58cm (W) x 52cm (D) x 14cm (H)
(Boxed):	22.8" (W) x 20.5" (D) x 5.5" (H)
Weight:	Nett: 5.54kg Gross: 6.5kg Nett: 12.2lbs Gross: 14.3lbs



Close-Up Of The CM-TB8 Front Left Hand Side.



Close-Up Of The CM-TB8 Front Right Hand Side.





# CM-TB8T Talkback Control Unit, CM-TB8 with CM-TBT Dual PSTN Telephone Hybrid



**Category:** Talkback & Commentary.

**Product Function:** Talkback controller with dual PSTN comms.

**Typical Applications:** Ideal in an OB van/

truck or small production gallery where talkback is needed to a remote location, or other country.

**Features:**

- Two independent telephone hybrids.
- Ethernet & front panel control.
- Auto-answer & auto disconnect.
- 8 Speed dials available.
- IFB on telephone channels.



CM-TBT Dual PSTN Card For the CM-TB8T.

The CM-TB8T is the CM-TB8, 8 Channel Talkback Control Unit, with the CM-TBT add-in card fitted.

The CM-TBT is a dual PSTN, telephone hybrid expansion card. It extends the talkback capability of the CM-TB8 by allowing telephone calls to be made and

received on two independent analogue direct exchange or PSTN lines.

The hybrids are fully configurable and are easy to setup via the CM-TB8 embedded web server. Simply select your location from a country code list to automatically configure the telephone interface for local

line conditions. This setting also configures the relevant auto disconnect mode which can be enabled if required. An option to auto answer an incoming telephone call can also be enabled.

Calls can be made and received by using an external telephone handset connected to each hybrid channel, or directly on the CM-TB8 using the channel controls. Each hybrid can independently speed dial one of the 8 user defined telephone numbers stored on the unit.

IFB modes are fully supported on the telephone channels allowing selected signals to be routed to a connected telephone call.

**Specification For CM-TB8T**

Bandwidth to Telephone Line:	125Hz – 3.6kHz, -3dB ref 1kHz
Telephone Line Impedance:	Nominally 600Ω - complex impedances set via country code
Telephone Line Impedance Range:	300Ω to 1500Ω
Connections:	2 x RJ11 Socket – line 2 x RJ11 Socket – handset
CM-TBT :	Add-in card for CM-TB8 with 2 x telephone hybrids.
CM-TB8T:	CM-TB8 including CM-TBT.
<b>Physical Specification</b>	
Dimensions (Raw):	15cm (W) x 10cm (D) x 3cm (H) 5.9" (W) x 3.9" (D) x 1.2" (H)
Dimensions (Boxed):	22.9cm (W) x 12.7cm (D) x 7.6cm (H) 9.0" (W) x 5.0" (D) x 3.0" (H)
Weight:	Nett: 0.2kg Gross: 0.3kg Nett: 0.4lbs Gross: 0.7lbs



CM-TB8T PSTN Configuration Page.



CM-TB8T Channels Config Page.



## CM-TB8G Talkback Control Unit, CM-TB8 with CM-TBG Dual GSM Interface



truck or small production gallery where talkback is needed from a remote location, or to staff in a remote location.

**Features:**

- Two separate quad band GSM circuits.
- Ethernet & front panel control.
- Auto-answer & auto disconnect.
- 8 Speed dials available.
- IFB on GSM channels.

**Category:** Talkback & Commentary.

**Product Function:** Talkback controller with dual GSM comms.

**Typical Applications:** Ideal in an OB van/

The CM-TB8G is the CM-TB8, 8 Channel Talkback Control Unit, with the CM-TBG add-in card fitted.

The CM-TBG is a dual GSM telephone expansion card. It extends the talkback capability of the CM-TB8 by allowing mobile telephone calls to be made and received via two independent quad band mobile telephone modules.

The GSM modules are configured via the CM-TB8 embedded web server. This provides access to features including network selection, telephone number storage and phone logs. Each module has its own internal SIM card slot and separate antenna connection which is mounted on the rear panel of the CM-TB8.

Telephone calls are made and received using the embedded web server or directly using the channel controls. The CM-TB8 can store 8 telephone numbers and each channel can speed dial the required number.



CM-TB8G GSM Configuration Page.

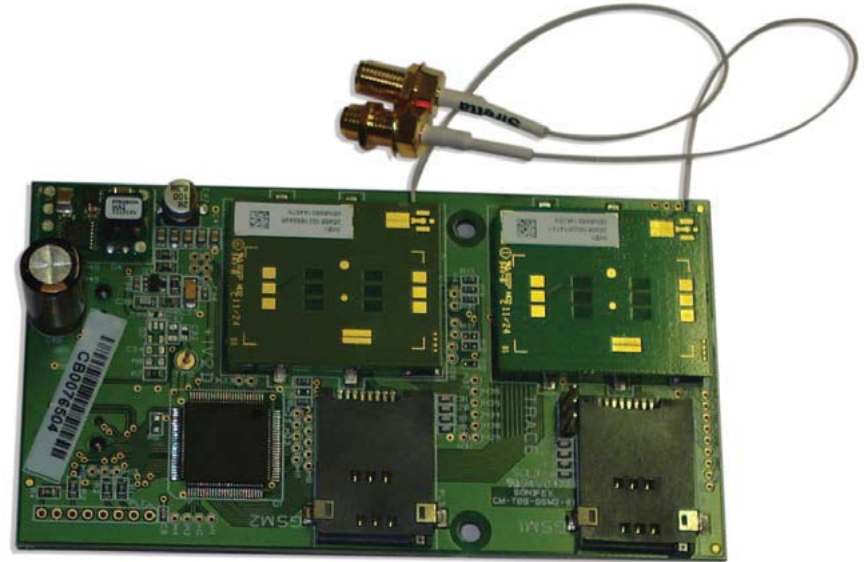

CM-TBG Dual GSM Card For the CM-TB8G.

IFB modes are fully supported on the telephone channels allowing selected input signals to be routed to a connected telephone call.

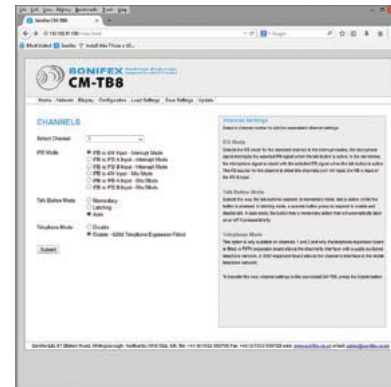

CM-TB8G GSM Enable Page.

**Specification For CM-TB8G**

Module Type:	Quad-Band EGSM 850 / 900 / 1800 / 1900MHz
Output Power:	Class 4 (2W) @ 850 / 900MHz Class 1 (1W) @ 1800 / 1900MHz
Sensitivity:	-107 dBm (typ.) @ 850 / 900MHz -106 dBm (typ.) @ 1800 / 1900MHz
Approvals:	Fully type approved conforming to R&TTE, CE, GCF, FCC, PTCRB, IC, Anatel
Connections:	2 x SMA Socket – antenna
CM-TB8 :	Add-in card for CM-TB8 with 2 x GSM line.
CM-TB8G :	CM-TB8 including CM-TBG.

**Physical Specification**

Dimensions (Raw):	15cm (W) x 10cm (D) x 3cm (H) 5.9" (W) x 3.9" (D) x 1.2" (H)
Dimensions (Boxed):	22.9cm (W) x 12.7cm (D) x 7.6cm (H) 9.0" (W) x 5.0" (D) x 3.0" (H)
Weight:	Nett: 0.2kg    Gross: 0.3kg Nett: 0.4lbs    Gross: 0.7lbs



## CM-GM1 Professional Gooseneck Condenser Microphone



**Category:** Talkback & Commentary.

**Product Function:** Gooseneck mic for use with commentary and talkback systems.

**Typical Applications:** Use with the CM-TB8, CM-CU21, CM-CU1 or any system which supports an XLR mic input. Large

scale conferences, public addresses and outdoor speeches.

### Features:

- High performance, extremely clear sound.
- High sensitivity, low self noise.
- Exceptional frequency response.
- Durable flexible gooseneck.
- XLR male base connection.
- Red LED around collar illuminates when phantom power is on.
- 350mm flexible neck.

This is a professional gooseneck condenser microphone which has a back electret condenser element with an ultra-cardioid polar pattern.

A red LED circling the head of the microphone illuminates when phantom power is applied to the mic. At the base of the mic is a male XLR plug connector to plug into intercoms and talkback systems.

It is 35cm long and has two flexible sections near the head and the base of the mic so that it can be moved into different orientations.

### Specification For CM-GM1

Element:	Black electret condenser
Polar pattern:	Ultra cardioid
Frequency Response:	50Hz – 15kHz
Sensitivity:	-38dB +- 3dB (0dB=1V/Pa at 1kHz)
Phantom Power Requirement:	9V-52V DC phantom.

### Equipment Type

CM-GM1 :	Professional gooseneck condenser microphone
----------	---

### Physical Specification

Dimensions (Raw):	47cm (L) x 1.5cm (Dia) 18.5" (L) x 0.6" (Dia)
Dimensions (Boxed):	50cm (W) x 4cm (D) x 4cm (H) 19.7" (W) x 1.6" (D) x 1.6" (H)
Weight:	Nett: 0.1kg    Gross: 0.2kg Nett: 0.2lbs    Gross: 0.4lbs





## CM-CU1 Commentator Unit 1 Commentator & Line Input



**Category:** Talkback & Commentary.

**Product Function:** Commentator unit for a single commentary position.

**Typical Applications:** Used in sports grounds and arenas by commentators to produce commentary & hear talkback.

**Features:**

- Commentator position with individual output; plus main mix output.
- Line input with configurable output and headphone presence.
- Talkback outputs selectable by the commentator, with built in limiter and adjustable gain.
- 5 Return audio circuits that are routed to headphones along with the

commentator input. Any source can be individually level controlled and sent to left, right or both ears.

- A wide input gain range and switchable phantom power allows support of a variety of microphone types including low output ribbon, headsets and high output phantom powered microphones.
- User preset adjustable limiter on main output with limit activity indication.
- Built in line-up tone for initial cabling checks.
- 21 Segment LED PPM meter showing main output level.
- Transformer balanced inputs & outputs.
- Fitted formica 'Sharpie' designation strips.
- Robust mechanical design with protection for potentiometer knobs.
- Universal AC mains, or 12-24 volt DC power.

The CM-CU1 offers the same high quality, robust specification as the CM-CU21, with a feature set tailored to single commentator applications.

It provides a fully featured commentator position and a line-level input. The unit has an individual commentator output, with an additional output providing a mix of commentator and line input audio. A limit

indicator on the main panel shows when the adjustable limiter on the main output is active, and a bright 21 segment LED PPM meter, which can be disabled, shows the main output level.

The line input can be configured to remain present at the mix output even if the commentator is off air, making it useful for routing crowd effects or pre-recorded



CM-CU1 Commentator Unit Top View.



material to the programme feed. Its presence in the commentator's headphones is also configurable to suit the application.

Four talkback output channels, with a built in limiter, are available to the commentator and they can be linked to provide simultaneous operation. Activation of one or more talkback channels removes the commentator audio from the main output until all talkback channels are deactivated.

A wide input gain range and switchable phantom power allows support of a variety of microphone types including low output ribbon mics, headsets and high output phantom powered microphones. There are 5 transformer balanced return audio inputs which, along with the commentator input, are routed to the headphone monitor controls. With these headphone controls, any monitor input can be adjusted and sent to either the left, right or both ears.



CM-CU1 Commentator Unit Front View.

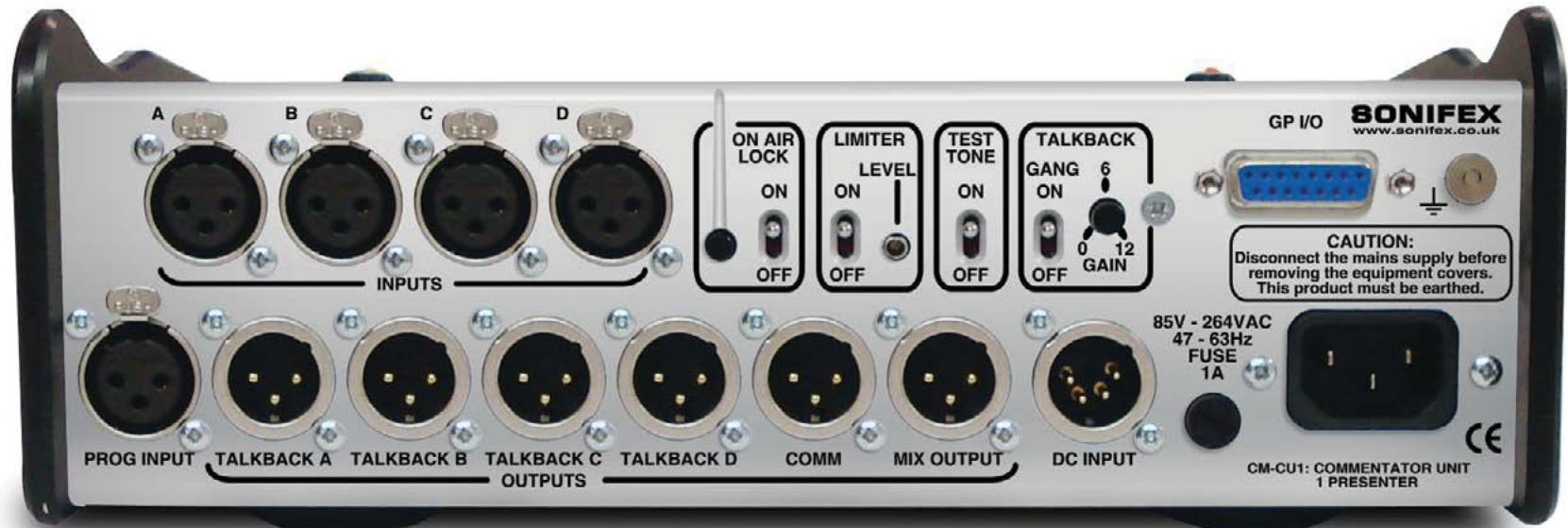

CM-CU1 Commentator Unit Rear View.



A GPIO port gives an open-collector driven output indication of any active On-Air or talkback channel and four remote inputs provide an external call/alert to each of the talkback controls.

The unit has a built in line-up tone generator for easy channel identification and cabling checks. When enabled the test-tone is routed to the required output simply by pressing the corresponding on air or talkback button. An automatic tone mode repeatedly sends different quantities of tone bursts to each output to make it effortless for a single technician to set up.

An On-Air lock switch prevents the On-Air button from being accidentally deactivated and a T/B Gang switch links the operation of talkbacks A, B, C & D.

A flexible range of options allow the Commentator Unit to be customised to better suit the operational and user's personal requirements. These include options for momentary or latching operation of the talkback buttons, permanently enabling or disabling the commentator input, default headphone signal routing and main panel indicator illumination levels.

The CM-CU1 Commentator Unit can be powered from a universal mains input between 85-264V AC at 47-63Hz, or from a 12-24V DC input.



CM-CU1 Commentator Unit Iso View.

## Specification For CM-CU1

### Microphone Input

Gain Range:	+20dB to +86dB
Maximum Input Level:	-6dBu
Equivalent Input Noise:	130dB Ref. 80dB gain with 150Ω termination
Equivalent Input Noise:	128dB Ref. 50dB gain with 150Ω termination
C.M.R.R.:	>60dB
Frequency Response:	±0.5dB 20Hz to 22kHz Ref 50dB gain @ 1kHz

### Electronically Balanced Line Input

Gain Range:	-83dB to +10dB
Maximum Input Level:	+25dBu
C.M.R.R.:	>70dB
Frequency Response:	±0.2dB 20Hz to 22kHz Ref 0dBu @ 1kHz

### Transformer Balanced Monitor Inputs

Gain Range:	-66dB to +11dB measured @ Headphone output
Maximum Input Level:	+21dBu
C.M.R.R.:	>55dB
Frequency Response:	±0.5dB 20Hz to 22kHz Ref 0dBu @ 1kHz

### Transformer Balanced Mix Output

Maximum Output Level (Limiter Off):	+24dBu
Frequency Response:	±0.5dB 20Hz to 22kHz Ref 0dBu @ 1kHz
Noise:	-94dB Average weighting Ref +8dBu
THD & N:	<0.02% Ref. 1kHz @ +8dBu
THD & N:	<0.065% Ref. 1kHz @ +18dBu
1% Distortion Point:	+18dBu @ 24Hz

### Transformer Balanced Talkback Outputs

Maximum Output Level Limited:	+8dBu
Frequency Response:	±0.5dB 20Hz to 22kHz Ref 0dBu @ 1kHz
Noise:	-94dB Average weighting Ref +8dBu
THD & N:	<0.02% Ref. 1kHz @ +8dBu
Gain Adjustment:	0dB to +12dB

### Electronically Balanced Comm Output

Maximum Output Level:	+25dBu
Frequency Response:	±0.2dB 20Hz to 22kHz Ref 0dBu @ 1kHz
Noise:	-98dB Average weighting Ref+8dBu
THD & N:	<0.002% Ref. 1kHz @ +8dBu

### Headphone Output

Gain Range:	-66dB to +11dB
Maximum Output Level:	+19dBu
Frequency Response:	±0.5dB 20Hz to 22kHz Ref 0dBu @ 1kHz
Noise:	-85dB Average weighting Ref +8dBu
THD & N:	<0.005% Ref. 1kHz @ +8dBu

### Main Panel Operational Controls & Indicators

On-Air Button:	Illuminated button with latching action
Talkback A, B, C & D Buttons:	Illuminated buttons with selectable momentary and/or latching action
Headphone Monitor Controls:	Input source level adjustment potentiometers Headphone channel selection switches
Line Input Level:	line input mode level potentiometer
PPM Meter:	21 segment display showing mix output level
Limit LED:	Indicates main output limiter is active, colour & brightness level is selectable
Power LED:	Indicates operating mode; normal or setup

### Front Panel Operational Controls

Phantom:	Switch to enable 48V microphone phantom power
Mic Gain:	Microphone gain potentiometer and range select switch selects +20dB to +56dB or +50 to +86dB

### Rear Panel Operational Controls

On Air Lock:	Switch to prevent On Air control from being deactivated Momentary push-button to override on air lock
T/B Gang:	Switch to link operation of talkbacks A, B, C & D
T/B Gain:	0dB to +12dB
Limiter:	Switch to enable limiter on mix output Limit level adjustment potentiometer
Test Tone:	Switch to enable 1 kHz line-up tone

### Configuration Options – Accessible via Setup Mode

On Air Control Mode:	Disabled, normal or permanently on
Talkback Button Action:	Momentary, latching or both
Headphone Routing:	Line-level input permanently routed/routed if on air to Commentator headphones Commentator input permanently routed/not routed to headphone monitors
Line Level Input Routing:	Line-level input permanently routed/not routed/routed if on air to main output
Display Preferences:	Limit LED colour and brightness Button LED brightness PPM meter LED brightness/disable
Permanent Option Backup:	Save/load options to/from Permanent backup or return to factory defaults

### Front Panel Connections

Headphone Output:	1 x locking headphone jack socket
Microphone Input:	1 x XLR-3 pin latching female
Line Input:	1 x XLR-3 pin latching female

### Rear Panel Connections

Prog, A, B, C & D Inputs:	5 x XLR-3 pin female (transformer balanced)
Comm Output:	1 x XLR-3 pin male (electronic balanced)
Talkback A, B, C & D Outputs:	4 x XLR-3 pin male (transformer balanced)
Mix Output:	1 x XLR-3 pin male (transformer balanced)
GPIO Port:	15-way 'D'-type socket
Mains Input:	Universal filtered IEC, continuously rated 85-264VAC, 47-63Hz, 10W
Fuse Rating:	Anti-surge fuse 1A 20 x 5mm
DC Input:	XLR-4 pin male 12V DC, 650mA Typical, 850mA Maximum 24V DC, 325mA Typical, 425mA Maximum
Earth Point:	M4 stud.
<b>Equipment Type</b>	
CM-CU1	Commentator unit, 1 presenter
<b>Physical Specification</b>	
Dimensions (Raw):	27cm (W) x 23cm (D) x 7cm (H - front) x 9.5cm (H - rear) 10.6" (W) x 9" (D) x 2.8" (H - front x 3.7" (H - rear)
Dimensions (Boxed):	38cm (W) x 35cm (D) x 20cm (H) 15" (W) x 13.8" (D) x 7.8" (H)
Weight:	Nett: 3.3kg Gross: 4.3kg Nett: 7.3lbs Gross: 9.4lbs
<b>Accessories</b>	
CM-CUTC:	Commentator unit transport case
Dimensions (Raw):	53cm (W) x 21cm (D) x 41.5cm (H) 20.9" (W) x 8.3" (D) x 16.3" (H)
Dimensions (Boxed):	60cm (W) x 26cm (D) x 42cm (H) 23.6" (W) x 10.2" (D) x 16.5" (H)
Weight:	Net: 4.0kg Gross: 5.0kg Net: 8.8lbs Gross: 11.0lbs



## CM-CU21 Commentator Unit 2 Commentators & 1 Guest



**Category:** Talkback & Commentary.

**Product Function:** Commentator unit for two commentary positions and a guest position.

**Typical Applications:** Used in sports grounds and arenas by commentators to produce commentary & hear talkback.

**Features:**

- 2 Commentator positions plus a guest position, each with individual outputs; plus 2 mix outputs.
- Talkback outputs selectable by the two main commentators, with built in limiter & adjustable gain.
- 4 Return audio circuits that are routed to headphones along with all the commentator inputs. Any source can be individually level controlled and

sent to left, right or both ears.

- A wide input gain range and switchable phantom power on each commentary position allows support of a variety of microphone types including low output ribbon, headsets and high output phantom powered microphones.
- Individually switched 48V phantom power on all microphone inputs.
- User preset adjustable limiter on main mix outputs with limit activity indication.
- Built in line-up tone for cabling checks.
- 21 Segment LED PPM meter showing main output level.
- Transformer balanced inputs and outputs.
- Fitted formica 'Sharpie' designation strips.
- Robust mechanical design with protection for potentiometer knobs.
- Universal AC mains, or 12-24 volt DC power.

The CM-CU21 is a high quality, portable Commentator Unit. Its sturdy construction and flexibility of features make it suitable for use in a wide variety of environments.

Sonifex has a solution for those situations where a separate commentary unit is required, or where ISDN/pots

communications, or a complex digital solution aren't needed. The CM-CU21 stand alone commentator unit is a rugged, reliable solution which includes all the features needed to ensure that up to two play-by-play announcers can provide their expertise, together with a guest position for

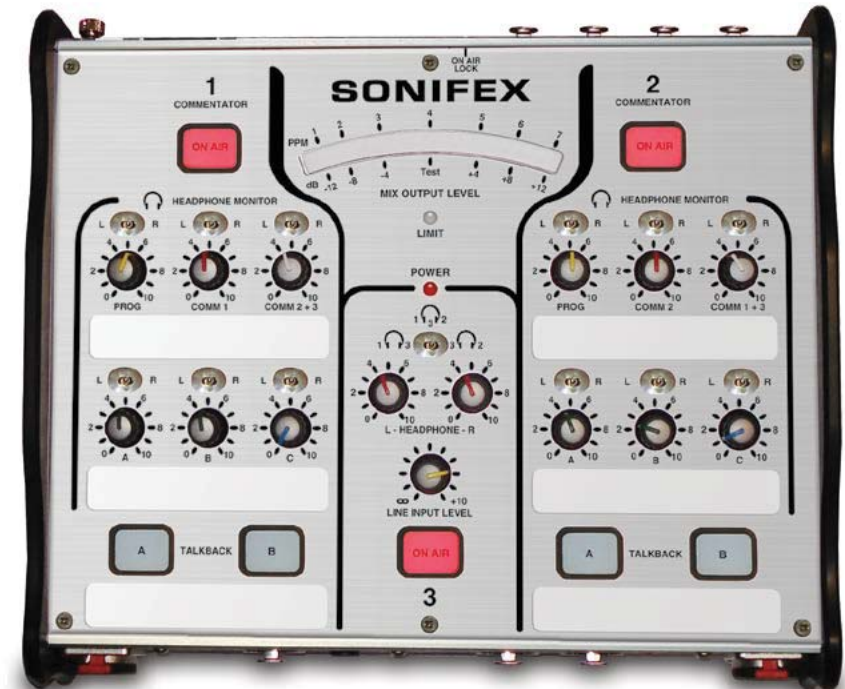

CM-CU21 Commentator Unit Top View.

further analysis by a visiting ex-professional pundit (color commentator in the USA), or co-commentator. The guest position can alternatively be used as a line-level input for special effects such as the sounds of the action and spectators, also heard in the background.

Each of the 3 announcer positions has an individual output, with two additional outputs providing a mix of all active commentary channels. A limit indicator on

the main panel shows when the adjustable limiter on the mix outputs is active, and a bright 21 segment LED PPM meter, which can be disabled, shows the main output level. Two talkback output channels, with a built in limiter and adjustable gain, are available to each of the two main commentators and they can be be linked to provide simultaneous operation.

A wide input gain range and switchable phantom power on each commentary



CM-CU21 Commentator Unit Front View.

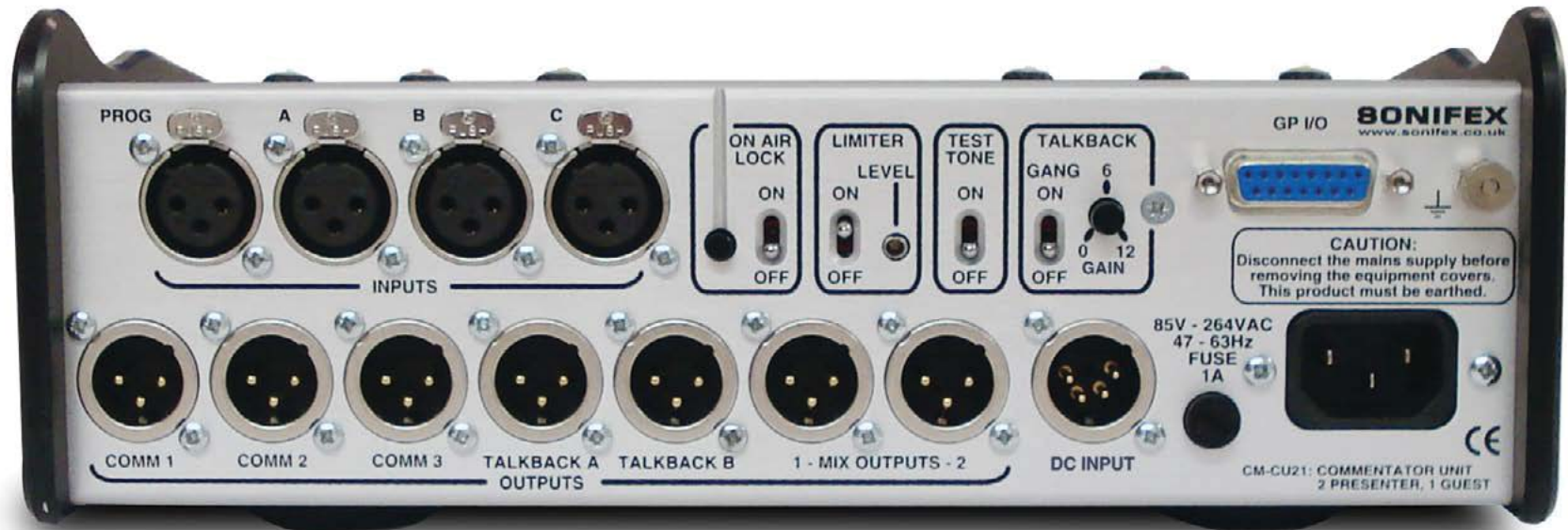

CM-CU21 Commentator Unit Rear View.



position allows support of a variety of microphone types including low output ribbon mics, headsets and high output phantom powered microphones. The microphone level controls are accessible on the front panel but can be protected from adjustment by an optional cover plate if required. There are 4 transformer balanced return audio inputs which, along with the commentator inputs, are routed to the headphone monitor controls. These could be used to pass referee remarks to the sportscasters, as well as comments from guests in the studio.

The headphone input controls are very comprehensive allowing either of the two main announcers total control so that any monitor input can be adjusted in volume and sent to either the left, right or both ears. The switches are slightly recessed so that they can't easily be knocked and the volume knobs are fitted so that the bottom skirt of the knob is below the level of the panel, so that they can't fall off. Fitted Formica 'Sharpie' designation strips are used under each of the level controls so that different input and source types can be dynamically annotated.

A GPIO port gives an independent open-collector driven output indication for any of the three active On-Air or four talkback channels. Four remote inputs provide an external call/alert to each of the talkback controls which flashes the selected T/B button amber when used, to indicate active talkback.

The unit has a built in line-up tone generator for easy channel identification and cabling checks. When enabled, the test-tone is routed to the required output simply by pressing the corresponding on air or talkback button.

An On-Air lock switch prevents the On-Air buttons from being accidentally deactivated and this can be over-ridden with a single push button on the rear panel for individual circumstances where an announcer needs to go off air. A talkback (T/B) gang switch links the operation of talkbacks A & B to make the talkback buttons easier to use by the announcers.



CM-CU21CP Commentator Unit Front Cover Plate.

A flexible range of options allow the CM-CU21 to be customised to better suit the operational and user's personal requirements. These include options for momentary or latching operation of the talkback buttons, permanently enabling or disabling any of the commentator inputs, default headphone signal routing and main panel indicator illumination levels.

The CM-CU21 Commentator Unit can be powered from a universal mains input between 85-264V AC at 47-63Hz, or from a 12-24V DC input, both on the rear panel. A transport case, the CM-CU21TP, is also available to protect the CM-CU21 which also has space for two headsets and/or microphones.

### Accessories

**CM-CU21CP:** This is an optional Commentator Unit Front Cover Plate which is attached to the front of the CM-CU21 to avoid accidental tampering with the microphone gain and phantom power control settings.

**CM-CUTC:** This is an optional carry case to transport the CM-CU1 or CM-CU21 commentator unit along with 2 x headsets and 2 x ribbon mics.



CM-CUTC Commentator Unit Transport Case.



## Specification For CM-CU21

### Microphone Input

Gain Range:	+20dB to +86dB
Maximum Input Level:	-6dBu
Equivalent Input Noise:	130dB Ref. 80dB gain with 150Ω termination
Equivalent Input Noise:	128dB Ref. 50dB gain with 150Ω termination
C.M.R.R.	>60dB
Frequency Response:	±0.5dB 20Hz to 22kHz Ref 50dB gain @ 1kHz

### Electronically Balanced Line Input

Gain Range:	-83dB to +10dB
Maximum Input Level:	+25dBu
C.M.R.R.	>70dB
Frequency Response:	±0.2dB 20Hz to 22kHz Ref 0dBu @ 1kHz

### Transformer Balanced Monitor Inputs

Gain Range:	-66dB to +11dB measured @ Headphone output
Maximum Input Level:	+21dBu
C.M.R.R.	>55dB
Frequency Response:	±0.5dB 20Hz to 22kHz Ref 0dBu @ 1kHz

### Transformer Balanced Main Outputs

Maximum Output Level (Limiter Off):	+24dBu
Frequency Response:	±0.5dB 20Hz to 22kHz Ref 0dBu @ 1kHz
Noise:	-94dB Average weighting Ref +8dBu
THD & N:	<0.02% Ref. 1kHz @ +8dBu
THD & N:	<0.065% Ref. 1kHz @ +18dBu
1% Distortion Point:	+18dBu @ 24Hz

### Transformer Balanced Talkback Outputs

Maximum Output Level Limited:	+8dBu
Frequency Response:	±0.5dB 20Hz to 22kHz Ref 0dBu @ 1kHz
Noise:	-94dB Average weighting Ref +8dBu
THD & N:	<0.02% Ref. 1kHz @ +8dBu
Gain Adjustment:	0dB to +12dB

### Electronically Balanced Comm Outputs

Maximum Output Level:	+25dBu
Frequency Response:	±0.2dB 20Hz to 22kHz Ref 0dBu @ 1kHz
Noise:	-98dB Average weighting Ref +8dBu
THD & N:	<0.002% Ref. 1kHz @ +8dBu

### Headphone Outputs

Gain Range:	-70dB to +7dB
Maximum Output Level:	+19dBu
Frequency Response:	±0.5dB 20Hz to 22kHz Ref 0dBu @ 1kHz
Noise:	-85dB Average weighting Ref +8dBu
THD & N:	<0.005% Ref. 1kHz @ +8dBu

### Main Panel Operational Controls & Indicators

On-Air 1-3 Buttons:	Illuminated buttons with latching action
Talkback A & B Buttons:	Illuminated buttons with selectable momentary and/or latching action
Headphone Monitor Controls:	Input source level adjustment potentiometers Headphone channel selection switches
Line Input Level:	Guest position line input mode level potentiometer
PPM Meter:	21 segment display showing mix output level, brightness level Is selectable
Limit LED:	Indicates mix output limiter is active, colour & brightness level is selectable
Power LED:	Indicates operating mode; normal or setup
<b>Front Panel Operational Controls</b>	
Phantom:	Switch to enable 48V microphone phantom power for positions 1 & 2
Phantom/Line:	Switch to enable 48V microphone phantom power or select line input mode for position 3
Mic Gain:	Microphone gain potentiometer and range select switch selects +20db to +56dB or +50dB to +86dB

### Rear Panel Operational Controls

On Air Lock:	Switch to prevent On Air controls from being deactivated Momentary push-button to override on air lock
T/B Gang:	Switch to link operation of talkbacks A & B
T/B Gain:	0dB to +12dB
Limiter:	Switch to enable limiter on mix outputs Limit level adjustment potentiometer
Test Tone:	Switch to enable 1 kHz line-up tone

### Configuration Options – Accessible via Setup Mode

On Air Control Mode:	Disabled, normal or permanently on
Talkback Button Action:	Momentary, latching or both
Headphone Routing:	Position 3 line mode input routed/not routed to positions 1 & 2 headphones Position 1-3 inputs permanently routed/not routed to headphone monitors
Display Preferences:	Limit LED colour and brightness Button LED brightness PPM meter LED brightness disable
Permanent Option Backup:	Save/load options to/from permanent backup or return to factory defaults

### Front Panel Connections

Headphone Outputs:	2 x locking headphone jack socket for positions 1 & 2 1 x headphone jack socket for position 3
Microphone Inputs:	2 x XLR-3 pin latching female for positions 1 & 2
Microphone/Line Input:	1 x XLR-3 pin latching female for position 3

### Rear Panel Connections

Prog, A, B & C Inputs:	4 x XLR-3 pin female (transformer balanced)
Comm1-3 Outputs:	3 x XLR-3 pin male (electronic balanced)
Talkback A & B Outputs:	2 x XLR-3 pin male (transformer balanced)
Mix 1 & 2 Outputs:	2 x XLR-3 pin male (transformer balanced)
GPIO Port:	15-way 'D'-type socket
Mains Input:	Universal filtered IEC, continuously rated 85-264VAC, 47-63Hz, 10W
Fuse Rating:	Anti-surge fuse 1A 20 x 5mm
DC Input:	XLR-4 pin male 12V DC, 650mA Typical, 850mA Maximum 24V DC, 325mA Typical, 425mA Maximum
Earth Point:	M4 stud.
<b>Equipment Type</b>	
CM-CU21	Commentator unit, 2 presenter and 1 guest positions

### Physical Specification

Dimensions (Raw):	27cm (W) x 23cm (D) x 7cm (H - front) x 9.5cm (H - rear) 10.6" (W) x 9" (D) x 2.8" (H - front) x 3.74" (H - rear)
Dimensions (Boxed):	38cm (W) x 35cm (D) x 20cm (H) 15" (W) x 13.8" (D) x 7.8" (H)
Weight:	Nett: 3.34kg Gross: 4.32kg Nett: 7.35lbs Gross: 9.5lbs

### Accessories

CM-CU21CP:	Commentator unit front cover plate
CM-CUTC:	Commentator unit transport case
Dimensions (Raw):	53cm (W) x 21cm (D) x 41.5cm (H) 20.9" (W) x 8.3" (D) x 16.3" (H)
Dimensions (Boxed):	60cm (W) x 26cm (D) x 42cm (H) 23.6" (W) x 10.2" (D) x 16.5" (H)
Weight:	Net: 4.0kg Gross: 5.0kg Net: 8.8lbs Gross: 11.0lbs



## CM-BH4W Belt-Pack 4-Wire Headphone Amp



CM-BH4W Front, Rear and Angled View.

The CM-BH4W is a portable, battery powered 4 wire communication unit for use in a multitude of TV and radio broadcasting applications. A battery powered mic input and headphone output allow monitoring of talkback and creation of content.

The CM-BH4W uses audio transformers at its input and output, providing galvanic isolation from outside interference, ensuring your communications are loud and clear, every time.

In 4-wire mode, the unit acts as a 2-way intercom, with input audio routed to the headset earpiece, and microphone audio is routed to the output upon pressing the

talk button. The output level is maintained at +2dBu peak level by a built-in AGC. In IFB mode, the input audio is routed to the output, and is interrupted by the microphone signal when the talk switch is pressed. The talk switch can easily be converted from momentary to latching operation to suit your application.

A low battery warning LED flashes when the 9V PP3 battery has depleted to 6V, giving plenty of notice to swap the battery. In addition, the CM-BH4W automatically switches off when the headset jack is removed, and the low power circuitry gives up to 150 hours use from a single alkaline 9V PP3 battery.



**Category:** Talkback & Commentary.

**Product Function:** Battery powered microphone and headphone amps allow use for talkback & 4-wire applications.

**Typical Applications:** Used in TV studio floors, sports grounds and arenas by presenters and cameramen to produce content and to hear talkback.

**Features:**

- Transformer balanced inputs & outputs.
- 4-wire and IFB modes.
- Low battery warning indicator.
- 150 hours from a single 9V PP3 battery.

### Specification For CM-BH4W & X

#### Mic In to Line Out

Mic Input Impedance: 1k5Ω Unbalanced for 200Ω dynamic microphone

Limiter Input Threshold: -60dBu

Line Output Level: +2dBu

Line Output Impedance: 150Ω Transformer balanced

#### Line In to Headphone Out

Line Input Impedance: >10kΩ Transformer balanced

Input Gain/Volume: Adjustable off to +10dB

Maximum Input Level: +24dBu

Maximum HP Output Level: +7dBu (ref 9V battery voltage, <1% THD, 100Ω load)

Minimum HP Impedance: 100Ω

#### Connections

Line Input: 1 x XLR 3 pin female socket (balanced)

Line Output: 1 x XLR 3 pin male plug (balanced)

Headset (CM-BH4W): 1 x ¼" (6.35mm) mono unbalanced jack socket

Headset (CM-BH4WX): 1 x XLR 4 pin male plug (balanced)

#### Equipment Type

CM-BH4W: Belt-pack 4-wire headphone amplifier

CM-BH4WX: Belt-pack 4-wire headphone amplifier with 4 pin XLR headset connector

#### Physical Specification

Dimensions (Raw): 12.5cm (W) x 6.7cm (D) x 4.8cm (H)  
4.9" (W) x 2.6" (D) x 1.9" (H)

Dimensions (Boxed): 22.9cm (W) x 12.7cm (D) x 7.6cm (H)  
9.0" (W) x 5.0" (D) x 3.0" (H)

Weight: Nett: 0.3kg Gross: 0.4kg  
Nett: 0.6lbs Gross: 1.0lbs



CM-BH4W Top and Bottom View.

The CM-BH4WX is a version of the CM-BH4W with a 4 pin XLR headset connection instead of a stereo jack connector. In all other respects it is the same as the CM-BH4W.



CM-BH4WX Top View.



## CM-BHA Belt Pack Headphone Amplifier With Limiter & Loudspeaker



**Category:** Talkback & Commentary.

**Product Function:** Battery powered headphone amp allows use for talkback & 4-wire applications.

**Typical Applications:** Used in TV studio floors, sports grounds and arenas by presenters and cameramen to hear talkback.

**Features:**

- Wide signal range capability.
- Transformer balanced inputs & outputs.
- Adjustable limiter protects the listener.
- Low battery warning indicator.
- 200 hours from a single 9V PP3 battery.

The CM-BHA is a portable, battery powered headphone amplifier for use in live applications such as in-the-field news reports.

The CM-BHA has a wide signal range and can apply gain of up to +20dB to the incoming signal. The volume control simultaneously modifies the output volume and the input gain, allowing input signals in excess of +24dBu to be reproduced without distortion.

The CM-BHA has an adjustable limiter to protect the listener from excessive levels indicated by a blue LED. The limiter is only enabled when an earpiece or headphones are used, and when it is activated by the toggle switch. It is disabled when no jack is inserted, allowing a higher volume to be passed to the speaker for "squawk mode" use.



CM-BHA Top and Bottom View.

Losing a cue feed due to batteries running out is not an option. With the CM-BHA, a low battery warning LED flashes when the



CM-BHA Front, Rear and Angled View.

9V PP3 battery has depleted to 6V, giving plenty of notice to swap the battery. The low power circuitry of the CM-BHA gives up to 200 hours use from a single alkaline 9V PP3 battery.

### Specification For CM-BHA

Input Impedance:	200kΩ electronically balanced
Input Limiter Threshold:	Adjustable -14dBu to 0dBu
Maximum Input Level:	+28dBu
Input Gain/Volume:	Adjustable -70dB to +20dB
Frequency Response:	20Hz – 20kHz ±0.5 (ref 0dBu 1kHz)
Noise:	<-75dBu A-weighted (ref 0dB gain)
Distortion:	<0.015% (ref +8dBu input, 0dB gain,

	10kΩ load)
Maximum HP	+16dBu (ref 9V battery voltage,
Output Level:	<1% THD, 2kΩ load) +12dBu (ref 6V battery voltage, <1% THD, 2kΩ load)
Minimum HP Impedance:	32Ω
Maximum Speaker Level:	+12dBu (ref 9V battery voltage, <1% THD) +6dBu (ref 6V battery voltage, <1% THD)

### Equipment Type

CM-BHA Belt Pack Headphone Amplifier with Limiter & Loudspeaker

### Physical Specification

Dimensions (Raw):	12.5cm (W) x 6.7cm (D) x 4.8cm (H)
Dimensions (Boxed):	22.9cm (W) x 12.7cm (D) x 7.6cm (H)
Weight:	Nett: 0.3kg Gross: 0.4kg Nett: 0.7lbs Gross: 0.9lbs



## TB-6D & TB-6R 6 Way Talkback Intercoms



**Category:** Talkback Intercoms.

**Product Function:** Provides communication & talkback between up to 7 studios/areas.

**Typical Applications:** Talkback within a facility or outside broadcast vehicle.

**Features:**

- Up to 7 areas can be connected.
- DC signalling system.
- Momentary & latched button operation.
- Built-in electret mic.
- Front panel mic optional.
- 2 stereo external inputs.
- Built-in loudspeaker.
- Headphones with level control.

The Sonifex Talkback Intercoms provide a cost effective way of enabling talkback between up to 7 areas in a studio complex.

Talkback refers to the standard method of communication between broadcast studios.

Each studio can have either a desktop, a rack-mount, or mixer-mounted intercom, usually containing a row of switch buttons.

Each switch button connects to another studio when pressed, and routes the presenter audio to it.

There are 2 products in the Sonifex Talkback Intercom range :

**TB-6D** 6 Way Talkback Intercom, desktop free standing

**TB-6R** 6 Way Talkback Intercom, 19" rack mounted

The TB-6D and TB-6R are general talkback interfaces which can be connected together to form a talkback system.

The TB-6D and TB-6R are used for general talkback between studios and use DC signalling, also known as ground lifting or ground signalling, to communicate with each other. These units can be installed in various locations throughout a studio complex and linked to one another, with each unit being able to talkback to up to 6 others connected together.

Most other talkback systems in general operation also use DC signalling, so you should be able to add these units into an existing installation.

**Desktop Or Rackmount**

The TB-6D and TB-6R are identical in operation, with the TB-6D used for desktop operation and the TB-6R available as a 2U rack-mount, for use for example, in a central apparatus room or central technical area.

**Talkback For Up To 7 locations**

Up to 7 locations or studios can communicate with each other. On each panel, there are 6 front panel buttons for talkback selection and 2 for external inputs. When a button is pressed, the button lights up and the talkback is active to that location.



TB-6D 6 Way Talkback Intercom Front View.

### Press & Release, Press & Hold Operation

The buttons work with both a momentary and latched operation. If you simply press the button, talkback will be on and can be cancelled by pressing the button again. If you press and hold the button, the selection is cancelled when released. So, if you wanted to listen to an external input, such as the radio station feed, or off-air monitor, you could simply press the EXT 1 button. If you receive talkback from another studio when the external input buttons are also pressed, the external inputs can be either

muted or mixed, depending on the setting of an internal jumper.

The talkback outputs and input are balanced signals on a 15-way male D-type plug and the talkback input can be adjusted from -28dB to 9dB using a rear panel preset pot.

### Onboard Electret Mic or External Mic

You can speak to the separate locations using the onboard front-panel electret mic or there is a separate external mic input on a 3 pin XLR female connector, into which you can plug a suitable gooseneck microphone. There is a rear panel switch to select

between the electret and separate input mic. The mic input gain range is adjustable via a rear panel preset pot between 74dB and 53dB.

### Monitoring External Inputs

The unit can monitor two external sources. The EXT 1 input is a balanced stereo input on a rear panel 9 pin D-type socket. The EXT 2 input is an unbalanced stereo input on the 9 pin D-type socket as well as dual phono sockets. EXT 1 is useful for monitoring a distributed signal, such as a radio tuner off-air feed, or an outside source routed from an ISDN codec. EXT 2 is useful for

monitoring a local source, such as a portable flashcard recorder/player, or the unbalanced soundcard output from a PC editing/playback package.

If you already use a mixer which has a talkback input and output, or continuous talkback output, or just a line level output which you want to use, by changing internal jumpers the intercom can be configured to use these connections instead of the on-board microphone and speaker/headphones. For example, if you have a mic channel on a mixer assigned to talkback and the presenter is using headphones for monitoring the mixer talkback, the Talkback Intercom can be used purely for talkback switching and for monitoring external inputs.

### Built-in Loudspeaker & Headphones

For monitoring, you can use either the built-in 1W loudspeaker, or headphones on a 6.35mm unbalanced stereo jack. The headphone output provides 150mW into 32-600Ω headphones. When the headphones are used, the speaker is automatically muted. The monitor speaker can be muted via a remote contact on the 9 pin D-type External Input connector, e.g., when used in an area with live microphones. Both monitor and headphone levels are fully adjustable between -60dB and 9dB using the front panel volume control.

TB-6D Rear View.







TB-6R Front View.



TB-6R Rear View.

## Specification For Talkback Intercoms

### Audio & Power Specification

Talkback Input/Outputs:	15 way male D-type plug (TB-6D & TB-6R) for 6 balanced talkback outputs and 1 balanced talkback input
Talkback Input Gain Range:	9dB to -28dB adjusted by rear panel preset pot
External Inputs & Mute:	9 way female D-type socket, for stereo unbalanced external input 1, stereo unbalanced external input 2 (or external talkback input/output), talkback control output and mute input
External Input 2:	Dual phono socket, stereo unbalanced in parallel with the 9 way female D-type socket
External Inputs Impedance:	> 30kΩ unbalanced > 40kΩ balanced
External Talkback Input Impedance:	> 30kΩ unbalanced
External Talkback Output Impedance:	< 80Ω unbalanced
External Microphone Input:	3 pin female XLR socket
Mic Input Impedance:	1.5kΩ balanced
Microphone Input Gain Range:	74dB to 53dB adjusted by rear panel preset pot
Headphone Output:	6.35mm (1/4") jack, unbalanced stereo capable of driving 150mW into 32-600Ω headphones
Headphone Output Gain Range:	9dB to < -60dB (off) adjusted by front panel pot
Loudspeaker Power:	1W
Mains Input Power:	85V - 264V AC, 47-63Hz, max 10W
Fuse Holder:	1A anti-surge fuse
<b>Equipment Type</b>	
TB-6D:	6 way talkback intercom, desk units
TB-6R:	6 way talkback intercom, 19" rackmount
<b>Physical Specification</b>	
Dimensions (TB-6D Raw):	22.5cm (W) x 22.4cm(D) x 9.1cm(H) 8.8" (W) x 8.8" (D) x 3.6" (H)
Dimensions (TB-6D Boxed):	33.0cm (W) x 26.0cm (D) x 15.0cm (H) 13" (W) x 10" (D) x 6" (H)
Dimensions (TB-6R Raw):	48.3cm (W) x 18.5cm (D) x 8.9cm (H)(2U) 19" (W) x 7.3" (D) x 3.5" (H) (2U)
Dimensions (TB-6R Boxed):	52.0cm (W) x 30.5cm (D) x 16.5cm (H) 20.5" (W) x 12" (D) x 6.5" (H)
Weight (TB-6D):	Nett: 1.25kg Gross: 2.5kg Nett: 2.75lbs Gross: 5.5lbs
Weight (TB-6R):	Nett: 2.6kg Gross: 4.5kg Nett: 5.7lbs Gross: 9.9lbs

### Radio Studio Application Using TB-6D & TB-6R

A typical application would be to distribute talkback and audio feeds around a radio or TV studio complex, as in this diagram.

The TB-6D and TB-6R units are daisy-chained together from location to location and the radio station output from an off-air receiver is distributed on input EXT 1 of each unit.

The EXT 2 input could be used in the news or sales area for monitoring local sources such as a PC audio output.

Linking the studios in this way allows all locations to talk to each other together with the ability to monitor 2 external feeds, with independent control of monitor muting and headphone/speaker levels.

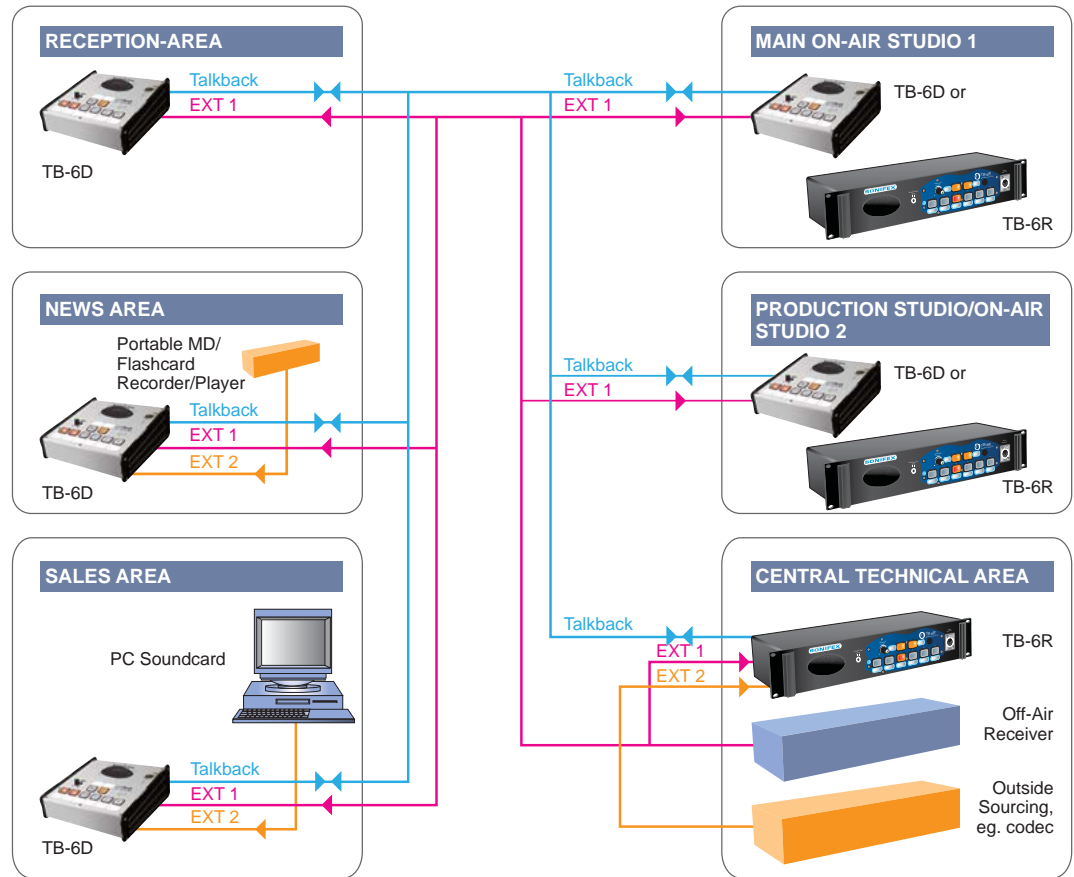



LEVEL FROM LINE

30 18 6 3

LEVEL TO LINE

12 8 4 2 0

## Telephony & Communications

<b>Telephone Hybrids</b>	233
Telephone hybrids, or telephone balance units (TBUs) provide the interface between professional audio equipment and the public telephone network.	
<b>Line Powered Hybrids</b>	234
CM-TBU Line Powered Telephone Balance Unit	234
CM-TLL Line Powered Telephone Line Listen Unit	235
<b>Analogue Telephone Hybrids</b>	236
HY-03, HY-03S & HY-03T Analogue Telephone Hybrids	236
<b>Digital Telephone Hybrids</b>	238
DHY-03, DHY-03S & DHY-03T Digital Telephone Hybrids	238
DHY-03EC Automatic Digital Telephone Balance Unit Eurocard	
2241 DHY-04, DHY-04S & DHY-04T Automatic Digital TBU, AES/EBU & Analogue I/O With Ethernet	242
<b>Digital GSM/2G Hybrids</b>	244
DHY-04G, DHY-04GS & DHY-04GT Automatic GSM Hybrid, AES/EBU & Analogue I/O With Ethernet	244
<b>HD Voice Hybrids</b>	246
DHY-04HD, DHY-04HDS & DHY-04HDT Automatic HD Voice & GSM Hybrid, AES/EBU & Analogue I/O With Ethernet	246
<b>Remote Control</b>	249
Sonifex Switchboard Software - Hybrid Remote Control	249
<b>IP Streamers</b>	
The Pro Audio Streamers are a range of three IP to audio and audio to IP streamers which have professional analogue and digital inputs and outputs.	251
<b>Pro Audio Streamers</b>	252
PS-SEND Audio to IP Streaming Encoder	252
PS-PLAY IP to Audio Streaming Decoder	254
PS-AMP IP to Speakers Streaming Decoder	256





**DHY-04G**  
GSM Hybrid

Speed Dial

1

2

Line Hold

AES  
Lock



3

Redial

4

**SONIFE**



## What Is A Telephone Hybrid?

Telephone hybrids, or telephone balance units (TBUs) provide the interface between professional audio equipment and the public telephone network. They provide protection for your equipment and the public telephone lines, allowing for varying line signals and line conditions. Automatically cancelling out the unwanted signal they also facilitate two-way communication down a single telephone line.

Each telephone hybrid has a telephone line connection, a handset connection and separate terminals for audio input and output from a broadcast mixer, or other professional audio source.

A large proportion of Sonifex hybrids are used in radio and television broadcasting applications for allowing external callers to be connected to the studio mixing console. Most of the other units are supplied to communication operations for allowing extremely effective conversion between 4-wire audio circuits and standard telephone lines.

A ringing detector can be used when you need to answer a call automatically, for instance, if a journalist files a report to a PC recorder over a telephone line, the call can be picked up after a set number of rings by the ringing detector. Both the HY-03 & DHY-03 have a built in ringing detector that is enabled by one of the configuration settings switches on the rear panel.

### Line Powered, Analogue, Digital or GSM or HD Voice?

Sonifex offer a few different hybrid units:

- The CM-TBU & CM-TLL line powered hybrids.
- The HY-03 analogue telephone hybrid.
- The DHY-03 DSP based telephone hybrid.

- The DHY-04 DSP based telephone hybrid.
- The DHY-04G DSP based GSM hybrid.
- The DHY-04HD DSP based HD Voice & GSM hybrid.

The extremely compact **CM-TBU** and **CM-TLL** units are portable and powered from the telephone line, providing a basic voice interface to a 4-wire circuit with separate level control of send and receive signals, useful for talkback applications.

The analogue **HY-03** hybrid is suitable for most general telephony applications and is often used in radio and TV stations, trading floors and conferencing centres. The HY-03 can be used for any application where a clean telephone signal is required and the line is not subject to signal delay.

The **DHY-03** offers near perfect performance, using DSP power to dramatically improve the unit's operation. The DHY-03 offers the features of the HY-03, but has some other benefits:

- Echo cancellation is possible and distortion of other mixed signals is greatly improved.
- Digital hybrids are more tolerant to fluctuating line conditions and are especially suitable for dealing with calls that have a slight signal delay, for example, satellite and conference calls.

The DHY-03 can recall signals from its memory buffer and allow for these delays without impairing performance.

The **DHY-04** is a redesign of the DHY-03 hybrid and adds Ethernet connectivity with a built-in web browser for configuration, control and dialling, combined AES/EBU digital and analogue audio inputs and front panel speed-dial buttons.

The **DHY-04G** uses a GSM SIM card to connect callers on the 2G/GSM cellular network to a radio/TV mixing console connected to the DHY-04G 4 wire input and output.

The **DHY-04HD** uses a 3G SIM card to connect callers on the 3G cellular networks using HD Voice wideband audio to provide a high quality audio call. This is ideal for broadcasters and journalists providing a frequency response up to 7kHz (twice that of a normal GSM or POTS connection). It converts 3G or GSM calls to the 4 wire audio signal to and from a connected mixing console.

**Note:** The CM-TBU, CM-TLL, HY-03, DHY-03 and DHY-04 products are operating on analogue telephone lines, not ISDN or IP digital lines. The "analogue" and "digital" refer to the processing used in the units.



## CM-TBU Line Powered Telephone Balance Unit



The CM-TBU line-powered telephone balance unit is compatible with all analogue direct exchange lines and provides a 4-wire communications system to interface with the telephone network.

The high degree of separation between send and receive signals makes it suitable for use in telephone IFB (interrupted foldback) applications and the high drive capacity at the 4-wire output enables a presenter's earpiece to be connected directly to the unit without an external amplifier.

This extremely compact unit is powered from the telephone line and provides an interface to a 4-wire circuit with separate level control of send and receive signals. Optimum rejection of the input signal on the

4-wire output is achieved in a bridge circuit by adjusting three elements (NULL, R-BAL and C-BAL) via potentiometers which simulate the complex line impedance. This can be used to compensate for local line variations or to adapt to the telephone systems of other countries, where line characteristics may differ. Optimization of the sidetone rejection does not involve the use of any test equipment and can be easily carried out while the system is in use.

Although the signal level being sent to the line can be manually adjusted using the 'SEND LEVEL' control over a wide range, the level control is followed by a limiter that prevents the telephone line signal level becoming overloaded or distorted. The limiter drives a



**Category:** Line Powered Telephone Hybrids.

**Product Function:** Provides separation between send and receive signals on an analogue telephone network and provides professional level balanced input & output signals.

**Typical Applications:** Talkback applications, e.g. to get cue feed to a remote presenter from a distant studio, hospital/community radio talkshows, house of worship remote listen & contribution to service.

**Features:**

- Isolated, full-duplex 4-wire interface to

direct non-digital telephone exchange lines.

- Line powered, requiring no battery or external power.
- Simple optimization of sidetone rejection with any country's telephone system.
- LEDs indicating 'Ring', 'Line Hold' and 'Limit' conditions.
- Input level control with line-sensing limiter and limit indicator.
- High drive output with level control for direct feed to presenter's earpiece, etc.
- Loop-through RJ11 line sockets provide universal connection to line and telephone set.
- Connection to the telephone set is maintained while the unit is in use.
- Small, rugged aluminium case.

'LIMIT' LED to indicate the onset of limiting.

Although the output stage can drive a presenter's earpiece in a telephone IFB application, the 'RECEIVE LEVEL' control may not be accessible to the presenter, who is normally situated some distance from the unit. The presenter may then require a local control of the earpiece signal level. The CM-TBU can be used to supply the correct signal level to a suitable battery powered earpiece belt-pack unit.

To enable communication between the 4-wire circuit and the telephone network, once the 4-wire and telephone line cable connections are made to the unit, the 'LINE CONNECT' switch can be pressed to power the unit from the line. This is indicated

by the 'ON' LED, and can either be done after an outgoing call has been dialled on a telephone set connected to the unit, or to answer an incoming call after the 'RING' LED is seen to flash. Note that a telephone set is not required for incoming calls unless an audible ring is required. If the sidetone level at the 4-wire output is found to be excessive, the outgoing signal level can be reduced using the 'SEND LEVEL' control or the balance controls can be adjusted to minimize it.

The unit is supplied with a connector and cable kit that enables connections to be made to both UK Telecom or the universal RJ11 sockets used in most telephone networks around the world.



## Specification For CM-TBU

### 4-Wire Input

Input Impedance:	10kΩ, transformer coupled
Input Connector:	3 pin XLR female connector
Input Level Range:	-12dBu to +4dBu before limiting when connected to an average line

### 4-Wire Output

Output Impedance:	150Ω, transformer coupled
Output Connector:	3 pin XLR male connector
Output Level Range:	-6dBu to +6dBu, for average line level

Sidetone Rejection:	30dB to 40dB average, depending on line characteristics
---------------------	---

2-Wire Off Hook Voltage:	6V minimum
--------------------------	------------

2 Wire Connectors:	RJ11 socket - line RJ11 socket - handset
--------------------	---

### Front Panel Operational Controls

Line Connect:	Push button with indicator
Send Level:	Small rotary control
Receive Level:	Large rotary control
Null Balance:	Recessed preset potentiometer
R Balance:	Recessed preset potentiometer
C Balance:	Recessed preset potentiometer
Ring LED:	Indicates incoming ringing
Limit LED:	Indicates limiter active
On LED:	Indicates connection to the telephone line

### Equipment Type

CM-TBU	Line powered telephone balance unit
--------	-------------------------------------

### Physical Specification

Dimensions (Raw):	7.7cm (W) x 8.3cm (D) x 4.2cm (H) 3.0" (W) x 3.3" (D) x 1.7" (H)
Dimensions (Boxed):	22.9cm (W) x 12.7cm (D) x 7.6cm (H) 9.0" (W) x 5.0" (D) x 3.0" (H)
Weight:	Nett: 0.25kg Gross: 0.75kg Nett: 0.60lbs Gross: 1.7lbs

## CM-TLL Line Powered Telephone Line Listen Unit



**Category:** Line Powered Telephone Hybrids.

**Product Function:** Provides a professional balanced audio output from the PSTN telephone line.

**Typical Applications:** Remote caller feed into seminars, remote cue & feedback source.

### Features:

- Audio interface to direct analogue exchange lines - receive calls with electrical isolation from the line.
- Line powered, requiring no battery or external power.
- LEDs indicating 'Ring' and 'On Hold' conditions.
- Loop-through line sockets provide in-line connection with existing telephone.
- Existing telephone remains connected when the unit is in use.
- Line connections to British or International sockets via supplied cable kit.
- Small, rugged aluminium case with XLR3 male 4-wire connector.



The CM-TLL provides a low-loss interface to receive audio from a telephone line. The line-powered unit is compatible with all analogue direct exchange lines and includes an LED indication of incoming calls.

The unit is intended to be used with an earpiece amplifier to receive an audio feed by telephone from a studio.

The line and telephone set are connected to the unit via the RJ11 connectors in order to make an outgoing call. A telephone may not be required if calls are only incoming, because telephone line ringing is indicated by a flashing LED built into the unit. In either case, the 'LINE CONNECT' switch is pressed to make the line connection. The 'ON' LED indicates that the unit is powered and that audio is routed to the line via the XLR plug.

## Specification For CM-TLL

### 4-Wire Output

Output Impedance:	150Ω, transformer coupled
Output Connector:	3 pin XLR male connector
Output Level:	Typically 0dBu for average line level

### 2-Wire

Off Hook Voltage:	6V minimum
2 Wire Connectors:	RJ11 socket - line RJ11 socket - handset

### Front Panel Operational Controls

Line Connect:	Push button with indicator
Ring LED:	Indicates incoming ringing
On LED:	Indicates connection to the telephone line

### Equipment Type

CM-TLL:	Line powered telephone line listen unit
---------	---

### Physical Specification

Dimensions (Raw):	7.7cm (W) x 8.3cm (D) x 4.2cm (H) 3.0" (W) x 3.3" (D) x 1.7" (H)
Dimensions (Boxed):	22.9cm (W) x 12.7cm (D) x 7.6cm (H) 9.0" (W) x 5.0" (D) x 3.0" (H)
Weight:	Nett: 0.20kg Gross: 0.70kg Nett: 0.50lbs Gross: 1.6lbs

# HY-03

## HY-03, HY-03S & HY-03T Analogue Telephone Hybrids



**Category:** Analogue Telephone Hybrids.

**Product Function:** Provides separation between send and receive signals on an analogue telephone network and provides professional level balanced input & output signals.

**Typical Applications:** Radio & TV station talk shows, telephony interface to the mixer.

**Features:**

- Fully automatic - adapts to varying line conditions and has automatic signal limiting.
- Local and remote line hold switching - calls can be remotely switched through a mixing console.
- Momentary or permanent latching remotes can be enabled.
- Balanced mic/line input - 10kΩ balanced input selectable for 0dBu clean feed line, or microphone level with adjustable gain.
- Balanced output - 0dBu low impedance

balanced output, with output gain adjustment.

- Mixed output - the output can be a mix of the caller and mic/line input signals for recording both sides of the telephone conversation.
- Integrated ring detector - automatic call answering after a pre-determined number of rings.
- Fitted with K-break disconnect detection as standard with an option for dial-tone disconnect using the optional HY-03DTD board. The HY-03DTD board

can be configured to disconnect on recognizing the dial tone used in a specific country.

- Line limiter, bandpass filter and output noise gate with preset threshold providing low distortion crystal clear audio.
- 28dB typical line balance rejection.
- Built in power supply with switchable 115V, or 230V, mains input.
- BAPT approval compliant with European PTT specifications.

The analogue HY-03 telephone hybrid sets the standard as an excellent value, high quality telephone hybrid.

The analogue HY-03 hybrid is suitable for most general telephony applications and is often used in radio and TV stations, trading floors and conferencing centres.

The HY-03 can be used for any application where a clean telephone signal is required and the line is not subject to signal delay.



HY-03 Single Free-Standing Automatic Analogue TBU - Front & Rear.

**Which Format Is Most Suitable ?**

The HY-03 analogue hybrids are available in three models :

- HY-03 Single free-standing automatic analogue TBU.
- HY-03S Single 19" rack mounted automatic analogue TBU with ringing detector.
- HY-03T Twin 19" rack mounted automatic analogue TBU.

HY-03S Single Rackmount Automatic Analogue TBU -- Front & Rear.



HY-03T Twin Rackmount Automatic Analogue TBU -- Front & Rear.



**Specification For HY-03**

Audio Specification	
Input Impedance - Line Mode (Clean Feed):	10k $\Omega$ balanced 0dB
Input Impedance - Microphone Mode:	200 $\Omega$ balanced
Clean Feed Limiting Input:	+4dBu
Microphone Level Range:	From 74dB to 40dB adjusted by preset pot
Bandwidth to Telephone Line:	250Hz - 4kHz, -3dB ref 1kHz
Telephone Line Impedance:	Nominally 600 $\Omega$
Telephone Line Impedance Range:	300 $\Omega$ to 1500 $\Omega$
Output Impedance:	50 $\Omega$ balanced floating 0dBu
Output Level Range:	+8dB to -14dB adjusted by preset pot
Rejection Ratio:	45dB on 1kHz tone, typically 28dB on complex waveforms, reference peak level of 0dB
Ring Detector Sensitivity:	1 ring to 6 rings
Power:	230V 50Hz, or 115V 60Hz. 6W for HY-03.

Connections	
Mic/Line Input:	XLR 3 pin female with push button mic/line selection
Line Output:	XLR 3 pin male
Telephone Line:	RJ11 6/4 socket
Telephone Handset/Instrument:	RJ11 6/4 socket
Remotes:	9-way D-type socket
Power:	IEC mains (CEE22)

Each unit is supplied with:  
 1 x RJ11 to RJ11 telephone line lead  
 1 x RJ11 to BT plug telephone line lead  
 1 x BT handset socket to RJ11 plug adapter,  
 1 x IEC mains lead fitted with moulded mains plug and 1 x handbook.

Accessories	
Order Code	Description
HY-03DTD	Dial tone detect add-on board
HY-03CON	Front panel conversion kit, HY-03S 19" (48cm) rack-mount front to HY-03 free standing
HY-03SCON	Front panel conversion kit, HY-03 free standing to HY-03S 19" (48cm) rack-mount front
HY-03TCON	Front panel conversion kit, HY-03 or HY-03S, to HY-03T 19" (49cm) rack-mount front

Order Code	Description	Height	Width	Depth* Weight	Total Nett Weight	Total Gross
HY-03	Automatic analogue TBU, free standing	4.5cm 1.8"	21.8cm 8.6"	17.5cm 7"	1.25kg 2.75lbs	2.0kg 4.4lbs
HY-03S	Automatic analogue TBU, 19" rack mounted	4.5cm (1U) 1.8" (1U)	48.3cm (19" rack width)	17.5cm 7"	1.30kg 2.9lbs	2.1kg 4.6lbs
HY-03T	Twin automatic analogue TBU, 19" rack mounted	4.5cm (1U) 1.8" (1U)	48.3cm (19" rack width)	17.5cm 7"	2.60kg 5.7lbs	4.0kg 8.8lbs

\*Depth is measured from the front to the end of the connectors fitted to the back of the unit. Note: If you are ordering the HY-03 for use in the USA, add the word "US" after the product code. The HY-03 uses different circuitry for US telephone exchanges.



# DHY-03

## DHY-03, DHY-03S & DHY-03T Digital Telephone Hybrids



**Category:** Digital Telephone Hybrids.

**Product Function:** Provides separation between send and receive signals on an analogue telephone network, provides professional level balanced input & output signals and has echo cancellation.

**Typical Applications:** Radio & TV station talk shows, telephony interface to the mixer.

**Features:**

- Fully automatic - adapts to varying line conditions and has automatic signal limiting.
- Fully adaptive echo cancellation to 127msec - default is 24msec.
- 76dB typical line balance rejection offering superb performance and crystal clear audio.
- Front panel input and output gain controls.
- Front panel LED metering of receive and send signals.
- Built-in conferencing for 2 hybrids, so that a single telco channel on a mixing desk can receive 2 calls.

- Integrated ring detector - automatic call answering after a pre-determined number of rings.
- Automatic call disconnection. Fitted with K-break, line polarity reversal and dial tone disconnect detection, defined by the country selection.
- Automatic ducking facility allows the talent to 'shout-down', or talk over, a caller by reducing the gain of the caller's signal if it goes above a certain level.
- Local and remote line hold switching - calls can be remotely switched through a mixing console.
- Line hold/release button to control line hold circuit, illuminates to indicate the status of the line and flashes to show ring status.
- DTMF tone recognition allowing a opto-isolated GPI output to be made on receipt of selected DTMF tones, e.g. for starting a studio automation recorder automatically to record a remote telephone interview.
- International operation with built-in configurable settings for each country. Country selection allows the unit to provide line impedance and a simulation circuit to match the country.
- RS232 serial port for remote control of the TBU, DTMF tone dialling and firmware upgrades to add new country settings.
- Remote port distributes the remote line connect switch and tally output, a momentary/latch selector and the DTMF detect output.
- The remote line connect switch can be either momentary or latching in its action.
- Balanced mic/line input - 10k balanced input selectable for OdBu clean feed line, or microphone level with adjustable gain.
- Balanced output - 0dBu low impedance balanced output, with output gain settings.
- Record output - the conferencing output can be set via a jumper to give a mix of the caller and mic/line input signals for recording both sides of the telephone conversation.
- Line limiter, bandpass filter and output noise gate with preset threshold providing low distortion audio.
- Built in universal power supply between 90V AC and 250V AC, 47-63Hz, IEC mains input.
- ETSI approval compliant with European PTT specifications.

The digital DHY-03 telephone hybrid is probably the best performing digital hybrid in the world, with simply stunning line balance rejection figures. For the best sounding audio calls you're likely to hear, you should specify the DHY-03.

The DHY-03 offers near perfect performance, using DSP power to dramatically improve the unit's operation.

The DHY-03 offers the features of the HY-03, but has some other benefits: Echo cancellation is possible and distortion of other mixed signals is greatly improved.

Digital hybrids are more tolerant to fluctuating line conditions and are especially suitable for dealing with calls that have a slight signal delay, for example, satellite and conference calls. The DHY-03 can recall signals from its memory buffer and allow for these delays without impairing performance.



DHY-03 Single Free Standing Automatic Digital TBU - Front & Rear.



DHY-03S Single Rackmount Automatic Digital TBU - Front & Rear.



DHY-03T Twin Rackmount Automatic Digital TBU - Front & Rear.



**Which Format Is Most Suitable ?**

The DHY-03 digital hybrids are available in three models :

- DHY-03 Single free-standing automatic digital TBU.
- DHY-03S Single 19" rack mounted automatic digital TBU.
- DHY-03T Twin 19" rack mounted automatic digital TBU.



DHY-03S Single Rackmount Automatic Digital TBU - Front.

### Specification For DHY-03

#### Audio Specification

Input Impedance - Line Mode (Clean Feed):	10kΩ balanced 0dB
Input Impedance - Conferencing:	10kΩ balanced 0dB (not for DHY-03EC)
Input Impedance - Microphone Mode:	2kΩ balanced (not for DHY-03EC)
Input Level Gain Range:	+6dB, 0dB, and -6dB adjusted by 3-position front panel switch, +10dB jumper
Microphone Level Gain Preset:	From 65dB to 35dB (not for DHY-03EC)
Maximum Input Levels:	Line +26dBu, mic -24dBu
Clean Feed Limiting Input:	-4dBu for CTR21 setting, other values available *
Bandwidth to Telephone Line:	250Hz - 4kHz, -3dB ref 1kHz
Telephone Line Impedance:	600Ω, 900Ω plus 14 other complex impedance circuits *
Output Impedance - Line Out:	50Ω balanced floating 0dBu
Output Impedance - Conference/Record:	50Ω balanced floating 0dBu
Output Level Gain Range:	+6dB, 0dB, and -6dB adjusted by 3-position front panel switch
Rejection Ratio:	76dB on tones or complex waveforms, reference peak level of 0dB

Ring Detector Sensitivity:	Off, 2, 4 or 6 rings
Power to DHY-03, S & T:	Universal 12Ω power supply: 90 to 250V AC; 47-63Hz; fused 1A
Power to DHY-03EC:	±15 V DC @ 160mA per rail or regulated +5V DC @ 600mA

\* These values are dependent on the actual country setting selected on the DHY-03

#### Connections

Mic/Line Input:	XLR 3 pin female, with push-button mic/line selection
Line Output:	XLR 3 pin male
Telephone Line:	RJ11 6/4 socket
Telephone Handset/Instrument:	RJ11 6/4 socket
Conferencing or Record Audio:	RJ45 socket
Remotes:	9-way D-type socket
RS232 Serial:	9-way D-type socket
Power:	IEC mains (CEE22)
Connections for Eurocard:	64 pin DIN 41612 male (plug)

Each DHY-03, S & T unit is supplied with:  
 1 x RJ11 to RJ11 telephone line lead  
 1 x RJ11 to BT plug telephone line lead  
 1 x BT handset socket to RJ11 plug adapter  
 1 x IEC mains lead fitted with moulded mains plug  
 1 x handbook and warranty card.

#### Accessories

Order Code	Description
DHY-03CON	Front panel conversion kit, DHY-03S to DHY-03
DHY-03SCON	Front panel conversion kit, DHY-03 free standing to DHY-03S 19" (48cm) rack-mount front
DHY-03TCON	Front panel conversion kit, DHY-03 or DHY-03S, to DHY-03T 19" (48cm) rack-mount front
DHY-03CONF	Conference cable to connect 2 x DHY-03 units
DHY-03RLY	Latching handset relay option for DHY-03, S and T (included in current models).

#### Physical Specification

Order Code	Description	Height	Width	Depth* Weight	Total Nett Weight	Total Gross
DHY-03	Automatic digital TBU, free standing	4.5cm 1.8"	21.8cm 8.6"	17.5cm 6.9"	1.4kg 3lbs	2.2kg 4.8lbs
DHY-03S	Automatic digital TBU, 19" (48cm) rack mounted	4.5cm (1U) 1.8" (1U)	48.3cm (19" rack width)	17.5cm 6.9"	1.45kg 3.2lbs	2.3kg 5lbs
DHY-03T	Twin automatic digital TBU, 19" (48cm) rack mounted	4.5cm (1U) 1.8" (19" rack width)	48.3cm (19" rack width)	17.5cm 6.9"	2.80kg 6.2lbs	4.4kg 9.7lbs
DHY-03EC	Automatic digital TBU with ringing detector Eurocard model (PCB 10x16cm)	12.9cm (3U) 5" (3U)	4.0cm (8E) 1.6" (8E)	19.0cm 7.5"	150g 0.3lbs	500g 1.1lbs

\*Depth is measured from the front to the end of the connectors fitted to the back of the unit.



Sci Dialpad Home Page.



Sci Disconnect Method Settings Page.

## DHY-03EC Automatic Digital Telephone Balance Unit Eurocard



**Category:** Digital Telephone Hybrids.

**Product Function:** Provides separation between send and receive signals on an analogue telephone network, provides professional level balanced input & output signals and has echo cancellation.

**Typical Applications:** Radio & TV station talk shows, telephony interface to the mixer.

**Features:**

- Eurocard format to get many cards into a small rackspace.
- Fully automatic - adapts to varying line conditions and has automatic signal limiting.
- Fully adaptive echo cancellation to 127msec - default is 24msec.
- 76dB typical line balance rejection offering superb performance and crystal clear audio.
- Front panel input and output gain controls.
- Integrated ring detector - automatic call answering after a pre-determined number of rings.
- Automatic call disconnection.

The DHY-03EC eurocard single digital telephone hybrid uses the same technology as the DHY-03 but is based in a card-style format for installation in a eurocard rack frame, or in certain broadcast mixers. Eurocards are supplied without a power supply, or casing, and are therefore significantly cheaper than the other units. It is pin compatible with the older DHY-02EC eurocard, but has the outstanding performance and most of the features of the DHY-03, with a few differences:

- The analogue input is line level only, though the 10dB professional/ consumer jumper is retained.
- There is no conferencing facility and consequently no record output option.
- The level meters are 2 tricolour LEDs.
- The level switches are now onboard 3 way jumpers.
- The remote outputs are connected via slide switches which means that the output signal can be either +5V, +15V or pull down to ground.
- The handset is connected to the telephone line via a divert relay.



*DHY-03EC - Automatic Digital Telephone Balance Unit Eurocard.*

## DHY-04 Telephone Hybrid

# DHY-04 Single Automatic Digital TBU, AES/EBU & Analogue I/O With Ethernet



**Category:** Digital Telephone Hybrids.

**Product Function:** Provides separation between send and receive signals on an analogue telephone network, provides professional level balanced input & output signals and has echo cancellation.

**Typical Applications:** Radio & TV station talk shows, telephony interface to the mixer.

**Features:**

- Fully automatic - adapts to varying line conditions and has automatic signal limiting.
- Fully adaptive echo cancellation to 127msec - default is 24msec.
- 70dB typical line balance rejection offering superb performance and crystal clear audio.
- Front panel input and output gain controls.
- Front panel LED metering of receive and send signals.
- Built-in conferencing for 2 hybrids, so that a single telco channel on a mixing desk can receive 2 calls.
- Integrated ring detector - automatic

call answering after a pre-determined number of rings.

- Automatic call disconnection. Fitted with K-break, line polarity reversal and dial tone disconnect detection, defined by the country selection.
- Automatic ducking facility allows the talent to 'shout-down', or talk over, a caller by reducing the gain of the caller's signal if it goes above a certain level.
- Local and remote line hold switching - calls can be remotely switched through a mixing console.
- Line hold/release button to control line hold circuit, illuminates to indicate the status of the line and flashes to show ring status.
- DTMF tone recognition allowing a opto-isolated GPI output to be made on receipt of selected DTMF tones, e.g. for starting a studio automation recorder automatically to record a remote telephone interview.
- International operation with built-in configurable settings for each country.
- Country selection allows the unit to provide line impedance and a simulation circuit to match the country.
- RS232 serial port for remote control of the TBU & DTMF tone dialling.
- Remote port distributes the remote

line connect switch and tally output, a momentary/latch selector and the DTMF detect output.

- The remote line connect switch can be either momentary or latching in its action.
- Balanced mic/line input - 10k balanced input selectable for 0dBu clean feed line, or microphone level with adjustable gain.
- Balanced output - 0dBu low impedance balanced output, with output gain settings.
- Record output - the conferencing output

can be set via a jumper to give a mix of the caller and mic/line input signals for recording both sides of the telephone conversation.

- Line limiter, bandpass filter and output noise gate with preset threshold providing low distortion audio.
- Built in universal power supply between 90V AC and 250V AC, 47-63Hz, IEC mains input.
- ETSI approval compliant with European PTT specifications.



The DHY-04 Front & Rear Panels.



## The Best Telephone Hybrid in the World Just Got Better!

The DHY-04 telephone hybrid is an enhanced redesign of the DHY-03, the best performing telephone hybrid in the world. It now has auto-sensing combined analogue and AES/EBU inputs and outputs, front panel speed dial buttons, together with an Ethernet interface to allow web browser access to the configuration and internal settings. All whilst still retaining stunning line balance rejection figures. For the best sounding audio calls you're likely to hear, you should specify the DHY-04. Key new features of the unit include:

- Auto-sensing combined analogue or AES/EBU XLR input.
- AES/EBU sample rates up to 24 bit/96kHz accepted.
- Configurable analogue or AES/EBU XLR output.
- Ethernet port for remote configuration via web browser GUI.
- Remote dialling and line hold control via Ethernet.
- Ethernet network interface can generate SNMP Traps for SNMP management systems.
- DTMF dial tone recognition for reporter remote access - a journalist can dial into the unit which can recognise a pre-programmed DTMF numeric password to automatically connect the journalist on-air.
- Four front panel speed-dial buttons for dialling internally preset phone numbers.
- Front panel Redial button for redialling the last number.



The DHY-04 Front Panel.

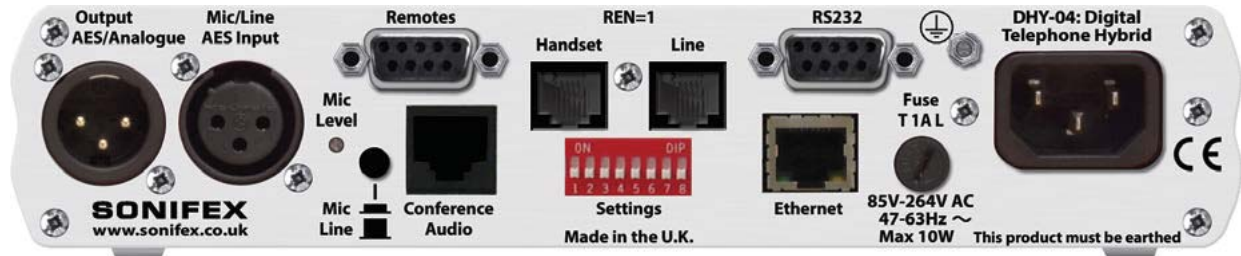

The DHY-04 Rear Panel.

The DHY-04S Front Panel.

The DHY-04S Rear Panel.

The DHY-04T Front Panel.

The DHY-04T Rear Panel.

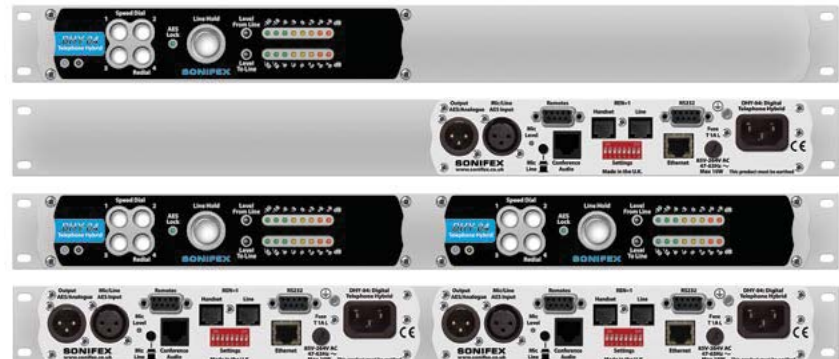

# DHY-04G GSM Hybrid

## DHY-04G Single Automatic GSM Hybrid, AES/EBU & Analogue I/O With Ethernet



**Category:** Digital Telephone Hybrids.

**Product Function:** Provides separation between send and receive signals on a 2G/GSM network, provides professional level balanced input & output signals and has echo cancellation.

**Typical Applications:** Radio & TV station outside broadcast vehicles for talk shows, telephony interface to the mixer. Backup hybrid to cover failure of main landline.

**Features:**

- Quad-Band EGSM 850 / 900 / 1800 / 1900MHz.
- Rear panel 2G/GSM SIM card insertion.
- Ethernet web server control and configuration.
- Front panel speed dial buttons with redial.
- Signal strength LED display.
- LEDs for SIM enabled and GSM network availability.
- Automatic operation.
- Combined AES/EBU and analogue input and output.

A new addition to the DHY-04 range is the ability for the DHY-04G version to be used on a GSM cellular (mobile) phone network instead of a telephone (POTS) line. The DHY-04G can accept a SIM card in the rear panel slot and by connecting a suitable GSM antenna, the DHY-04G can receive and make high quality broadcast calls over the cellular network, converting the GSM call to the 4 wire audio signal to and from a connected mixing console. The GSM module used in the DHY-04G is quad-band GSM, so it can take and make calls on any 2G network.

Ideal for studios in remote locations, for OB vans and trucks on the move, and in emergency situations where a telephone landline can't be guaranteed, the DHY-04G offers outstanding performance.

The DHY-04G has all features of the DHY-04 (read cellphone/mobile features instead of telephony features in the listed bullet point specification) together with some additional front panel indicators. There are two LEDs, one for SIM enabled and one for GSM Network availability. Additionally there is a push button which allows the GSM signal level to be displayed on the meter LEDs.



The DHY-04G Front & Rear Panels.



DHY-04G Home Page.



DHY-04G Configuration Page.





The DHY-04G Front Panel.



The DHY-04G Rear Panel.

**Which Format Is Most Suitable ?**

The DHY-04G GSM hybrids are available in three models :

- DHY-04G Single free-standing GSM TBU.
- DHY-04GS Single 19" rack mounted GSM TBU.
- DHY-04GT Twin 19" rack mounted GSM TBU.

The DHY-04GS Front Panel.



The DHY-04GS Rear Panel.



The DHY-04GT Front Panel.



The DHY-04GT Rear Panel.



**DHY-04HD**  
HD Voice Hybrid

## DHY-04HD Single Automatic HD Voice & GSM Hybrid, AES/EBU & Analogue I/O With Ethernet



**Category:** Digital Telephone Hybrids.

**Product Function:** Provides separation between send and receive signals on a 2G/GSM network, provides professional level balanced input & output signals and has echo cancellation.

**Typical Applications:** Radio & TV station outside broadcast vehicles for talk shows, telephony interface to the mixer. Backup hybrid to cover failure of main landline.

**Features:**

- Five band UMTS/HSPA+850 / 900 / 1800 / 1900 / 2100MHz.
- Rear panel 2G GSM or 3G SIM card insertion.
- Ethernet web server control and configuration.
- Front panel speed-dial buttons with redial.
- Signal strength LED display.
- LEDs for SIM enabled and GSM network availability.
- Automatic operation.
- Combined AES/EBU and analogue input and output.



The DHY-04HD Front & Rear Panels.

The DHY-04HD HD Voice Hybrid is used on a 3G or GSM cellular (mobile) phone network instead of a telephone (POTS) line. The DHY-04HD can accept a SIM card in the rear panel slot and by connecting a suitable GSM antenna, it can receive and make high quality broadcast calls over the cellular network, converting the 3G or GSM call to the 4 wire audio signal to and from a connected mixing console. The module used in the DHY-04HD is quad-band GSM and 5 band UMTS/HSPA+, so it can take and make calls on any 2G GSM, or 3G network.

It is ideal for studios in remote locations, for OB vans and trucks on the move, and in emergency situations where a telephone landline can't be guaranteed, the DHY-04HD offers outstanding performance.

The DHY-04HD has all features of the DHY-04 together with some additional front panel indicators. There are two LEDs, one for SIM enabled and one for GSM Network availability. Additionally

there is a push button which allows the mobile signal level to be displayed on the meter LEDs.

**HD Voice:**

HD Voice uses a coding system (also known as WB-AMR) for audio data that provides a significant enhancement on the quality of cellular phone calls. It is ideal for broadcasters and journalists providing a frequency response up to 7kHz (twice that of a normal GSM or POTS connection).

The use of HD Voice is dependent on 3 criteria:

1. The method has to be supported by the network, (and this may be limited by your contract), and when different networks are involved in the call, the interoperability between the networks.
2. The actual equipment used by both ends of the call must be HD Voice compatible. Both these requirements will be established on call connection, which leads to the third criteria.





The DHY-04HD Front Panel.



The DHY-04HD Rear Panel.

3. The signal quality can vary during the call. Normally the hybrid will be used in a fixed location (even OB trucks are normally stationary), so the position of the antenna can be refined for best signal quality. However the far end may be from a cellular phone, so may vary in quality and which can lead to dynamic bandwidth changes during a call. It is mostly true that network providers will only handle HD Voice on 3G networks though, in theory, it should also be compatible with enhanced 2G networks.

**Which Format Is Most Suitable ?**

The DHY-04HD HD Voice hybrids are available in three models :

- DHY-04HD Single free-standing HD Voice Hybrid.
- DHY-04HDS Single 19" rack mounted HD Voice Hybrid.
- DHY-04HDT Twin 19" rack mounted HD Voice Hybrid.

The DHY-04HDS Front Panel.



The DHY-04HDS Rear Panel.



The DHY-04HDT Front Panel.



The DHY-04HDT Rear Panel.





Specification For DHY-04, DHY-04G & DHY-04HD

Audio Specification Analogue Audio I/O	DHY-04	DHY-04G	DHY-04HD
Input Impedance - Line Mode (Clean Feed): 10kΩ balanced 0dB	Yes	Yes	Yes
Input Impedance - Conferencing: 10kΩ balanced 0dB	Yes	Yes	Yes
Input Impedance - Microphone Mode: 2kΩ balanced	Yes	Yes	Yes
Input Level Gain Range: +6dB, 0dB, and -6dB adjusted by 3-position front panel switch, +10dB jumper	Yes	Yes	Yes
Microphone Level Gain Preset: From 65dB to 35dB	Yes	Yes	Yes
Maximum Input Levels: Line +26dBu, mic -24dBu	Yes	Yes	Yes
Clean Feed Limiting Input: -4dBu for CTR21 setting, other values available *	Yes	Yes	Yes
Output Impedance - Line Out: 50Ω balanced floating 0dBu	Yes	Yes	Yes
Output Impedance - Conference/Record: 50Ω balanced floating 0dBu	Yes	Yes	Yes
Output Level Gain Range: +6dB, 0dB, and -6dB adjusted by 3-position front panel switch	Yes	Yes	Yes
<b>Audio Specification Digital Audio I/O</b>			
Input Impedance: 110Ω ±20% balanced	Yes	Yes	Yes
Output Impedance: 110Ω ±20% balanced	Yes	Yes	Yes
Sample Frequency Range: 30 - 100kHz (i.e. including 32kHz, 44.1kHz, 48kHz, 64kHz, 88.2kHz & 96kHz)	Yes	Yes	Yes
Signal Level: 2V/7V peak to peak min/max	Yes	Yes	Yes
Analogue Input Level for Full Scale Digits: +18dBu	Yes	Yes	Yes
Maximum Input Level: 0dBFS but internally limited to -6dBFS	Yes	Yes	Yes
Maximum Output Level: -6dBFS	Yes	Yes	Yes
<b>Telephone Line</b>			
Bandwidth to Telephone Line: 250Hz - 4kHz, -3dB ref 1kHz	Yes	No	No
Telephone Line Impedance: 600Ω, 900Ω plus 14 other complex impedance circuits *	Yes	No	No
Rejection Ratio: 80-88dB on complex waveforms, reference peak level of 0dBFS	Yes	Yes	Yes
Ring Detector Sensitivity: Off, 1, 2, 3, or 4 rings	Yes	Yes	Yes
<b>GSM Connection</b>			
Module Type: Quad-Band EGSM 850 / 900 / 1800 / 1900MHz	No	Yes	Yes
5-band UMTS/HSPA+ 850 / 900 / 1800 / 1900 / 2100MHz	No	No	Yes
	No	No	Yes
Output Power: Class 4 (2W) @ 850 / 900MHz,	No	Yes	Yes
Class 1 (1W) @ 1800 / 1900MHz	No	Yes	Yes
Class 3 (0.25W 24dBm) @ UMTS	No	No	Yes
Class E2 (0.5W 27dBm) @ EDGE 850/900	No	No	Yes
Class E2 (0.4W 26dBm) @ EDGE 1800/1900	No	No	Yes
Sensitivity: -107 dBm (typ.) @ 850 / 900MHz,	No	Yes	No
-106 dBm (typ.) @ 1800 / 1900MHz	No	Yes	No
-109 dBm (typ.) @ GSM 850 / 900MHz	No	No	Yes
-110 dBm (typ.) @ DCS1800 / PCS1900MHz	No	No	Yes
-111 dBm (typ.) @ UMTS	No	No	Yes
Approvals: Fully Type approved conforming with R&TTE, European - CE, GCF, North America - FCC, PTCRB, IC, Brazil - ANATEL	No	Yes	Yes
<b>Power Supply</b>			
Power to DHY-04, S & T	Universal 12W power supply: 90 to 250V AC; 47-63Hz; fused 1A	Yes	Yes

\* These values are dependent on the actual country setting selected on the DHY-04

Connections		DHY-04	DHY-04G	DHY-04HD		
Mic/Line/AES-EBU Input:	XLR 3 pin female, with push-button mic/line selection	Yes	Yes	Yes		
Line/AES-EBU Output:	XLR 3 pin male	Yes	Yes	Yes		
Telephone Line:	RJ11 6/4 socket	Yes	No	No		
Telephone Handset/Instrument:	RJ11 6/4 socket	Yes	No	No		
GSM Antenna:	SMA socket	No	Yes	Yes		
Conferencing or Record Audio:	RJ45 socket	Yes	Yes	Yes		
Remotes:	9-way D-type socket	Yes	Yes	Yes		
Ethernet:	RJ45 socket	Yes	Yes	Yes		
RS232 Serial:	9-way D-type socket	Yes	Yes	Yes		
Power:	IEC mains (CEE22)	Yes	Yes	Yes		
<b>Accessories Order Code Description</b>						
DHY-04CON	Front Panel Conversion Kit, DHY-04S to DHY-04					
DHY-04SCON	Front panel conversion kit, DHY-04 free standing to DHY-04S 19" (48cm) rack-mount front					
DHY-04TCON	Front panel conversion kit, DHY-04 or DHY-04S, to DHY-04T 19" (48cm) rack-mount front					
DHY-04GCON	Front Panel Conversion Kit, DHY-04GS to DHY-04G					
DHY-04GSCON	Front panel conversion kit, DHY-04G free standing to DHY-04GS 19" (48cm) rack-mount front					
DHY-04GTCON	Front panel conversion kit, DHY-04G or DHY-04GS, to DHY-04GT 19" (48cm) rack-mount front					
DHY-04HDCON	Front Panel Conversion Kit, DHY-04HDS to DHY-04HD					
DHY-04HDSCON	Front panel conversion kit, DHY-04HD free standing to DHY-04HDS 19" (48cm) rack-mount front					
DHY-04HDTCON	Front panel conversion kit, DHY-04HD or DHY-04HDS, to DHY-04HDT 19" (48cm) rack-mount front					
DHY-04CONF	Conference Cable to Connect 2 x DHY-04(G or HD) Units					
<b>Physical Specification</b>						
Order Code	Description	Height	Width	Depth*	Total Nett Weight	Total Gross Weight
DHY-04 (Raw):	Automatic digital telephone hybrid, free standing					
DHY-04G (Raw):	Automatic digital GSM hybrid TBU, free standing	4.5cm 1.8"	21.8cm 8.6"	17.5cm 6.9"	1.4kg 3lbs	2.2kg 4.8lbs
DHY-04HD (Raw):	Automatic digital HD hybrid TBU, free standing					
DHY-04, DHY-04G & DHY-04HD (Boxed):		6cm 2.4"	34cm 13.4"	27cm 10.6"		
DHY-04S (Raw):	Automatic digital telephone hybrid, rack mounted					
DHY-04GS (Raw):	Automatic digital GSM hybrid TBU, rack mounted	4.5cm (1U) 1.8" (1U)	48.3cm (19" rack width)	17.5cm 6.9"	1.45kg 3.2lbs	2.3kg 5lbs
DHY-04HDS (Raw):	Automatic digital HD hybrid TBU, rack mounted					
DHY-04S, DHY-04GS & DHY-04HDS (Boxed):		6.8cm 2.7"	58.8cm 23"	27cm 10.6"		
DHY-04T (Raw):	Twin automatic digital telephone hybrid, rack mounted					
DHY-04GT (Raw):	Twin automatic digital GSM hybrid TBU, rack mounted	4.5cm (1U) 1.8" (1U)	48.3cm (19" rack width)	17.5cm 6.9"	2.80kg 6.2lbs	4.4kg 9.7lbs
DHY-04HDT (Raw):	Twin automatic digital HD hybrid TBU, rack mounted					
DHY-04T, DHY-04GT & DHY-04HDT (Boxed)		6.8cm 2.7"	58.8cm 23"	27cm 10.6"		

\*Depth is measured from the front to the end of the connectors fitted to the back of the unit.

## Free Sonifex Switchboard Software - Remote Control of DHY-04/G/HD Hybrids

Software for remote control of the DHY-04 range of digital telephone hybrids is available for download free of charge. The software runs on Windows 7/8/10 and allows the control of up to 24 digital hybrids, including the GSM (DHY-04G) and HD Voice (DHY-04HD) versions of the products, all from one screen.

The software includes a Phone Book, a Chat Screen, Speed Dials, a Dial Pad and a Broadcast Clock.

It uses a local or networked SQL database for shared access to the hybrids and the interface is designed for use with a Full HD resolution touchscreen, although it can be used with traditional mouse and keyboard inputs.

To download, please go to the Software Downloads section of the Sonifex website.

The screenshot displays the Sonifex Software Switchboard interface. At the top left, the 'LINES' section shows a status bar with '1' and 'DHY-04HD'. Below this is a 'DIAL PAD' with buttons for DIAL, DROP, BACK, CLR, and speed dials (SD1-SD7, RE). To the right is a 'CLOCK' showing '15:59' and '59' on 'Tuesday, 12 May 2015'. The main area is the 'PHONE BOOK' with a table of callers and locations. At the bottom, there is a navigation bar with 'PHONE BOOK', 'DIAL PAD', 'SPEED DIALS', 'LINES', and 'CLOCK'. A search bar for 'CALLER' and a numeric keypad are also visible.

Caller	Location	Number	Note
1 Caller 1	Location 1	11 111 1111	Called 1st
2 Caller 2	Location 2	22 222 2222	Called 2nd
3 Caller 3	Location 3	33 333 3333	Called 3rd
4 Caller 4	Location 4	44 444 4444	Called 4th
5 Caller 5	Location 5	55 555 5555	Called 5th
6 Caller 6	Location 6	66 666 6666	Called 6th
7 Caller 7	Location 7	77 777 7777	Called 7th
8 Caller 8	Location 8	88 888 8888	Called 8th
9			
10			
11			
12			
13			
14			
15			

**SONIFEX**



**POWER**

**STATUS**



## IP Streamers Pro Audio Streamers

The Pro Audio Streamers are a range of three IP to audio and audio to IP streamers which have professional analogue and digital inputs and outputs. They allow audio to be streamed around a building, wan or lan using IP audio and CAT5 cabling infrastructure. Typical applications include:

- As a backup STL (studio to transmitter link).
- For audio confidence monitoring in remote locations, such as at a radio transmitter site.
- For distribution of audio and music around a building, such as for passing audio to speakers in a conference room.
- As an internet-based IP music distribution system.
- As a tannoy, paging or IP based public address system.
- For in-house audio applications and distribution.
- For streaming internet radio in bars and clubs.
- For radio and music channels in hotel rooms distributed via an IP network.
- For playing audio from a PC, a jukebox application, or from a USB stick.

There are three products in the range providing encoding/decoding and streaming:

The PS-SEND converts an audio input to an IP stream.

The PS-PLAY reads an IP stream and outputs to balanced and unbalanced audio line levels.

The PS-AMP reads an IP stream and outputs audio to stereo speakers.



*PS-SENDS Audio to IP Streaming Encoder.*



*PS-PLAYS IP to Audio Streaming Decoder.*



*PS-AMPS IP to Speakers Streaming Decoder.*



## PS-SEND Audio to IP Streaming Encoder



**Category:** Pro Audio Streamers.

**Product Function:** Audio to IP converter.

**Typical Applications:** See the front page of this section for application ideas.

### Features:

- Audio to IP streamer.
- Built-in web server for configuration.
- Balanced & unbalanced analogue audio inputs.
- AES/EBU, S/PDIF and TOSlink digital audio inputs.
- Front panel headphone monitor with volume control.
- 6 x GPI for triggering remote events.

**The PS-SEND is a freestanding audio to IP converter which is also available in a 1U rack-mount as the PS-SENDS.**

It receives audio from a number of user selectable external stereo sources including balanced and unbalanced analogue audio, AES/EBU, S/PDIF & TOSlink digital audio. Once an audio source is selected, the unit encodes the audio in real time and sends it to the network as an encoded stream. The audio stream can be distributed over an IP-

based network to one or more PS-PLAY or PS-AMP units or other proprietary servers such as those for Icecast or Shoutcast.

All the configuration settings for the unit are accessed via a local web-server built into it. The type of encoding and the transport mechanism are defined by selecting the connection from a pre-defined list. The PS-SEND encodes an audio source into an MP3 (from analogue or digital inputs), G.711 or PCM (from analogue inputs only) audio stream using HTTP, RTP, raw UDP or raw TCP protocols, including multicast support and the following encoder types are available: Mpeg1 & 2 Layer3, MP3-CBR (constant bit-rate), PCM linear and A-law, U-law, with 8kHz-48kHz sample rates. The unit can configure its own IP address using DHCP/BOOTP, IPzator or AutoIP. A readout of the set IP address can be heard on every reset using SONICIP technology, if selected. Remote level monitoring is also possible using SNMP traps.

Two red and green front panel LEDs indicate what state the unit is currently in, be it normal operational mode or bootstrap mode, and also indicates the current network connection status. A blue LED denotes power to the unit. The input being routed to the IP stream can be



monitored on the front panel 1/4" (6.35mm) stereo jack socket in combination with a headphone volume knob.

The rear panel has 2 x RJ45 connectors, one for the 10/100Mbit Ethernet interface and one for GPI connections. The PS-SEND has 6 x GPIs which can be used to trigger the sending of the audio stream and which can also be used to trigger remote events using an output relay on the PS-PLAY and PS-AMP. There is a 9 way D-type RS232 serial connection for control of the unit by automation systems and firmware updates. The unit can be remote controlled via serial connection, TCP or UDP.

Power to the unit is via a universal supply 85V - 264V fused IEC mains socket.

**Specification For PS-SEND**

Analogue Inputs:	2 x XLR 3 pin (balanced)( L&R) 2 x RCA phono (unbalanced) ( L&R)
Analogue Max	18dBu XLR balanced
Input Level:	8dBu RCA phono unbalanced
Input Impedance:	20kΩ bridging (analogue balanced)
Input Impedance:	20kΩ (analogue unbalanced)
Analogue Input SNR:	74dB
Input THD:	0.02% Relative
Interchannel	80dB (Ref FSD)
Isolation (Cross Talk):	
Digital Inputs:	1 x AES/EBU XLR 3 pin female 1 x S/PDIF RCA phono 1 x TosLink optical input
Analogue Outputs:	1 x 6.35mm (1/4") jack headphone socket
Headphones Output:	Drives 150mW into 32Ω to 600Ω stereo headphones
GPIs (General Purpose Inputs):	6 x GPIs, selectable via webpage control on RJ45 socket
Serial Port:	1 x 9 way D-type socket, used to send control commands and update firmware
Ethernet Port:	1 x RJ45 socket. Remote control commands can be sent via TCP or UDP as well as firmware updates
Mains Input:	Filtered IEC, 85 - 264VAC, 47 - 63 Hz, 10W, max
Fuse Rating:	Anti-surge fuse 1A 20 x 5mm

**Audio Codec Specifications PS-SEND**

G.711 (U Law/A Law 8kHz to 48kHz sampling rate)  
WAV (IMA ADPCM+ 16bit PCM uncompressed: 8kHz to 48kHz)  
MP3 MPEGv1 Layer 3 (32, 44.1 and 48 kHz, CBR)  
MP3 MPEGv2 Layer 3 (16, 22.05 and 24 kHz, CBR)

**General Features**

Supported network transport protocols  
RTP - UDP  
HTTP - TCP  
Raw UDP  
Raw TCP  
Can also act as Icecast/Shoutcast source  
SNMP - traps for remote management  
DHCP, BOOTP, IPzator or AUTOIP - Dynamic IP address resolution  
SonicIP IP Address readout

**Physical Specification**

<b>PS-SEND</b>		
Dimensions (Raw):	22cm (W) x 13.7cm (D) x 4.3cm (H)	
	8.67" (W) x 5.39" (D) x 1.7" (H)	
Dimensions (Boxed):	34cm (W) x 27cm (D) x 6cm (H)	
	13.4" (W) x 10.6" (D) x 2.4" (H)	
Weight:	Nett: 1.0kg Gross: 1.7kg	
	Nett: 2.2lbs Gross: 3.7lbs	
<b>PS-SENDS</b>		
Dimensions (Raw):	48.3cm (W) x 13.7cm (D) x 4.3cm (H)	
	19" (W) x 5.39" (D) x 1.7" (H)	
Dimensions (Boxed):	58.8cm (W) x 27cm (D) x 6.8cm (H)	
	23" (W) x 10.6" (D) x 2.7" (H)	
Weight:	Nett: 1.1kg Gross: 1.8kg	
	Nett: 2.4lbs Gross: 4.0lbs	



PS-SEND Home Page.



PS-SEND Streaming Settings Page.



PS-SEND Network Settings Page.



## PS-PLAY IP to Audio Streaming Decoder



PS-PLAY IP to Audio Streaming Decoder.



**Category:** Pro Audio Streamers.

**Product Function:** IP to audio converter.

**Typical Applications:** See the front page of this section for application ideas.

**Features:**

- IP to audio streamer.

- Built-in web server for configuration.
- Balanced & unbalanced analogue audio outputs.
- AES/EBU, S/PDIF and TOSlink digital audio outputs.
- Front panel headphone monitor with local & remote volume control.
- USB port acts as an audio source.
- Can decode from a multitude of services, e.g. Shoutcast, Icecast.
- 2 x GPO relays controlled remotely from a PS-SEND.

**The PS-PLAY is a freestanding IP to audio converter which is also available in a 1U rack-mount as the PS-PLAYS.**

It takes an IP audio feed and converts it to a number of simultaneous stereo outputs: balanced and unbalanced analogue audio, AES/EBU, S/PDIF & TOSlink digital audio outputs.

As for the PS-SEND, all the configuration settings for the unit are accessed via a local web-server built into it. The unit can decode one of a number of audio streams, such

as those generated by the PS-SEND (MP3, G.711 and PCM) and including Ogg Vorbis audio files from external USB as well as from sources such as Shoutcast, Icecast (Internet radio), VLC and from RTP servers. The unit can receive streams from HTTP (TCP/IP) and RTP (UDP) protocols, as well as raw TCP and UDP packets. The unit can also configure its own IP address using DHCP/BOOTP, IPzator or AutoIP. A readout of the set IP address can be heard on every reset using SONICIP technology, if selected.

Two red and green front panel LEDs indicate what state the unit is currently in, be it normal operational mode or bootstrap mode, and also indicates the current network connection status. A blue LED denotes power to the unit. The audio output can be monitored on the front panel ¼" (6.35mm) stereo jack socket in combination with a headphone volume knob. The analogue audio outputs can be switched to be either a fixed level output or to be controlled by the front panel volume knob. The volume can also be adjusted, as well as many other features, using an infra-red remote control (available separately).

The PS-PLAY can be configured with up to 3 sources. The sources are prioritized in number order. If one has failed, the next one will attempt to play. If all fail, an

external USB drive will be used as a back-up source. The external USB plugs into the USB socket on the front of the unit. This enables the PS-PLAY to act as a USB audio player, playing any of the audio formats previously mentioned.

The rear panel has 2 x RJ45 connectors, one for the 10/100Mbit Ethernet interface and one for GPIO connections. The PS-PLAY has 2 output relay contacts which can triggered remotely over IP from a connected PS-SEND unit. There is a 9 way D-type RS232 serial connection for control of the unit by automation systems and for firmware updates. The unit can be remote controlled via serial connection, TCP or UDP and remote management of the unit is also possible using SNMP traps.

Power to the unit is via a universal supply 85V - 264V fused IEC mains socket.

**Specification For PS-PLAY**

Analogue Outputs:	2 x XLR 3 pin (balanced)( L&R) 2 x RCA phono (unbalanced)( L&R) 1 x ¼ inch (6.35mm) stereo jack headphone socket
Analogue Max Output Level:	18dBu XLR balanced 8dBu RCA phono unbalanced
Output Impedance:	<50Ω (analogue balanced)
Output Impedance:	<75Ω (analogue unbalanced)
Output SNR:	94dB
Output THD:	0.03% Relative
Interchannel Isolation (Cross Talk):	80dB (Ref FSD)
Analogue Output Range:	-60dB to 18dB via front panel control knob, or optional IR controller
Digital Outputs:	1 x AES/EBU XLR 3 pin female 1 x S/PDIF RCA phono 1 x TOSLink optical input
Headphones Output:	Drives 150mW into 32Ω to 600Ω stereo headphones
USB Port:	1 x USB A socket
GPOs (General Purpose Outputs):	2 x switchable relay contacts (simultaneously switched) controlled from PS-SEND
Serial Port:	1 x 9 way D-type socket, used to send control commands and update firmware
Ethernet Port:	1 x RJ45 socket. Remote control commands can be sent via TCP or UDP as well as firmware updates.
IR Remote Receiver:	Remote commands can be sent using optional remote control via built in IR sensor
Mains Input:	Filtered IEC, 85 - 264VAC, 47 - 63 Hz, 10W, max
Fuse Rating:	Anti-surge fuse 1A 20 x 5mm

**Audio Codec Specifications PS-PLAY**

G.711 (U Law/A Law 8kHz to 48kHz sampling rate)  
WAV (IMA ADPCM+ 16bit PCM uncompressed: 8kHz to 48kHz)  
MP3 MPEGv1 Layer 3 (32, 44.1 and 48kHz, CBR +VBR +ABR)  
MP3 MPEGv2 Layer 3 (16, 22.05 and 24kHz, CBR +VBR +ABR)  
Ogg Vorbis (floor 1)

**General Features**

Supported network transport protocols  
RTP - UDP  
HTTP - TCP  
Raw UDP  
Raw TCP  
SNMP - traps for remote management  
DHCP, BOOTP, IPZator or AUTOIP - Dynamic IP address resolution  
SonicIP IP Address readout

**Physical Specification**

<b>PS-PLAY</b>	Dimensions	22cm (W) x 13.7cm (D) x 4.3cm (H)
	(Raw):	8.67" (W) x 5.39" (D) x 1.7" (H)
	Dimensions (Boxed):	34cm (W) x 27cm (D) x 6cm (H)
		13.4" (W) x 10.6" (D) x 2.4" (H)
	Weight:	Nett: 1.0kg Gross: 1.7kg Nett: 2.2lbs Gross: 3.7lbs

**PS-PLAYS**

	Dimensions	48.3cm (W) x 13.7cm (D) x 4.3cm (H)
	(Raw):	19" (W) x 5.39" (D) x 1.7" (H)
	Dimensions (Boxed):	58.8cm (W) x 27cm (D) x 6.8cm (H)
		23" (W) x 10.6" (D) x 2.7" (H)
	Weight:	Nett: 1.1kg Gross: 1.8kg Nett: 2.4lbs Gross: 4.0lbs



PS-PLAY Home Page.



PS-PLAY Advanced Stream Settings Page.



PS-PLAY Network Settings Page.



## PS-AMP IP to Speakers Streaming Decoder



**Category:** Pro Audio Streamers.

**Product Function:** IP to audio converter.

**Typical Applications:** See the front page of this section for application ideas.

**Features:**

- IP to audio speaker terminals streamer.
- Built-in web server for configuration.
- 1 x stereo speaker terminal outputs.
- Front panel headphone monitor with local & remote volume control.
- USB port acts as an audio source.
- Can decode from a multitude of services, e.g. Shoutcast, Icecast.
- 2 x GPO relays controlled remotely from a PS-SEND.

The PS-AMP is a freestanding unit which converts an IP audio stream directly to speaker outputs.

It is also available in a 1U rack-mount as the PS-AMPS. The PS-AMP has the same feature-set as the PS-PLAY except that there are no individual audio outputs other than the speaker terminals. The PS-AMP uses an integrated 2 x 15W D-class amplifier to deliver audio directly to a pair of connected speakers.

For further information on features please refer to the PS-PLAY.



PS-AMP IP to Speakers Streaming Decoder



### Specification For PS-AMP

Analogue Outputs:	2 x speaker connectors (2 each black and red terminals) 1 x 1/4" (6.35mm) stereo jack headphone socket
Headphones Output:	Drives 150mW into 32Ω to 600Ω stereo headphones
Headphone Level Range:	-60dB – 18dB via front panel control knob or optional IR controller
USB Port:	1 x USB A socket
GPOs (General Purpose Outputs):	2 x switchable relay contacts (simultaneously switched) controlled from PS-SEND
Serial Port:	1 x 9 way D-type socket, used to send control commands and update firmware
Ethernet Port:	1 x RJ45 socket. Remote control commands can be sent via TCP or UDP as well as firmware updates.
IR Remote Receiver:	Remote commands can be sent using optional remote control via built in IR sensor
Speaker Power:	15W per channel into 8Ω @ 10% THD+N
Mains Input:	Filtered IEC, 85 - 264VAC, 47 - 63 Hz, 60W max
Fuse Rating:	Anti-surge fuse 1A 20 x 5mm
<b>Audio Codec Specifications PS-AMP</b>	
G.711 (U Law/A Law 8kHz to 48kHz sampling rate)	
WAV (IMA ADPCM+ 16bit PCM uncompressed: 8kHz to 48kHz)	
MP3 MPEGv1 Layer 3 (32, 44.1 and 48kHz, CBR +VBR +ABR)	
MP3 MPEGv2 Layer 3 (16, 22.05 and 24kHz, CBR +VBR +ABR)	
Ogg Vorbis (floor 1)	

### General Features

Supported network transport protocols  
 RTP - UDP  
 HTTP - TCP  
 Raw UDP  
 Raw TCP  
 SNMP - traps for remote management  
 DHCP, BOOTP, IPZator or AUTOIP - Dynamic IP address resolution  
 SonicIP IP Address readout

### Physical Specification

<b>PS-AMP</b>	
Dimensions (Raw):	22cm (W) x 13.7cm (D) x 4.3cm (H) 8.67" (W) x 5.39" (D) x 1.7" (H)
Dimensions (Boxed):	34cm (W) x 27cm (D) x 6cm (H) 13.4" (W) x 10.6" (D) x 2.4" (H)
Weight:	Nett: 1.0kg    Gross: 1.7kg Nett: 2.2lbs    Gross: 3.6lbs
<b>PS-AMPS</b>	
Dimensions (Raw):	48.3cm (W) x 13.7cm (D) x 4.3cm (H) 19" (W) x 5.39" (D) x 1.7" (H)
Dimensions (Boxed):	58.8cm (W) x 27cm (D) x 6.8cm (H) 23" (W) x 10.6" (D) x 2.7" (H)
Weight:	Nett: 1.1kg    Gross: 1.9kg Nett: 2.4lbs    Gross: 4.2lbs



PS-AMP Home Page.



PS-AMP Advanced Stream Settings Page.



PS-AMP Network Settings Page.





ON AIR

92.5 ABC  
Central Coast  
The ABC Sydney  
abc.net.au/sydney

Sonifex SignalLED Sign.  
Photo courtesy of ABC Erina & OnAir Solutions.



## Studio Illuminated Signs

The SignalLED range of illuminated RGB LED signs are a range of signs designed for use outside recording studios, on-air & production studios, meeting rooms, conference rooms and for fixed installations. The sign itself contains the control electronics, and RGB LEDs are used, so the signs can be simply configured onsite for your particular requirements.

SignalLED Range of LED Signs	260
Custom Signs	262



*Sonifex SignalLED Sign.  
Photo courtesy of ABC Erina & OnAir Solutions.*



## SignalLED Range of LED Signs



**Category:** SignalLED Illuminated Signs.

**Product Function:** Signage for outside studio/office doors and on studio walls to indicate Mic Live, Recording, etc

**Typical Applications:** MIC LIVE, ON-AIR, PHONE and RECORD signs for radio/TV studios, TX-REH for production galleries, MEETING IN PROGRESS for board rooms, SILENCE PLEASE outside lecture theatres.

### Features:

- Low power consumption, only 4W.
- Maintenance free, LED lighting.
- Multi-coloured RGB LEDs offering 9 different colours.
- Sign can be made to flash, pulse, fade and be on or off.
- Flush-mounting as standard or end/ceiling-mounting with kits.
- 20cm (8") or 40cm (16") widths or 2 x 20cm (2 x 8").
- Standard wording includes: MIC LIVE, ON AIR, RECORD, PHONE, TRAFFIC FLAG ON, AD BREAK, TX, REH, REHEARSAL, DOOR,

OBIT, NO ENTRY, EXIT, SILENCE PLEASE, MEETING IN PROGRESS, INTERVIEW IN PROGRESS.

- Custom signs can be etched with company logos, different wording or graphics.
- 2 x GPIs for control from a light switch, or fader GPO (pull down to 0V).
- Supplied as standard as red/green switching.
- Use separate remote control (LD-RPC) to program the colour, switching mode or brightness.
- Supplied complete with fixings & DC power supply.

The SignalLED range of illuminated RGB LED signs are a new range of signs designed for use outside recording studios, on-air & production studios, meeting rooms, conference rooms and for fixed installations. The sign itself contains the control electronics, and RGB LEDs are used, so the signs can be simply configured onsite for your particular requirements.

### Different Display Modes

Five modes of illumination are available:

- Constant illumination.
- Flashing, regularly on/off.
- Pulsing - flashing, then off, repeated
- Fading
- Off

### RGB LEDs - Any Colours Possible

The illuminating LEDs in the unit are RGB meaning that the colour of the sign can be selected on installation.

You can configure the sign from one of 9 colours: white, green, red, blue, brick red, yellow, orange, cyan and magenta.



9 different colours of the SignalLED Sign.

### Single or Twin Signs

Each sign is 40cm or 20cm long. The 40cm signs can be split into two 20cm sides which can be separately, or jointly controlled, e.g. you can have a 40cm 'ON AIR' sign, or twin 2 x 20cm signs, such as 'ON AIR' and 'MIC LIVE'.



LD-40F1ONA Single Flush Mounting 40cm 'ON AIR' Sign.



LD-40F2ONA-MCL Twin 'ON AIR' & 'MIC LIVE' sign.

### Single 20cm Flush Mounting Sign

These are the available choices for the smaller 20cm flush-mounting signs. Custom signs can be made to order, if required.



LD-20F1REC Single Flush Mounting 20cm 'RECORD' Sign.



LD-20F1ONA Single Flush Mounting 20cm 'ON AIR' Sign.



LD-20F1MCL Single Flush Mounting 20cm 'MIC LIVE' Sign.

### LD-KC1 Ceiling Mounting Kit

The LD-KC1 mounting kit can be used to attach a 40cm or 20cm flush mounting sign to the ceiling or a desktop.



The LD-KC1 mounting kit used to attached the sign to the ceiling.



The LD-KC1 mounting kit used to attached the sign to the desktop.



The LD-KC1 mounting kit.

### Dual Control Inputs

The sign can be controlled by either, or both, of 2 pull-low inputs, e.g. a single input can be used to control a single 'MIC LIVE' sign, or 2 inputs can be used to control a twin 'TX' and 'REH' sign with independent control of each side of the sign.

### 7V-36V DC Input Option

For a small additional cost, the SignalLED main circuit board can be modified to accept a DC input in the range 7V-36V, for example, if you have a 12V or 24V distributed DC power network.

**Please note** that for 7V – 36V 'LDD' orders, a DC power supply is not included as standard.

When placing your order, or requesting a quotation, please either:

Change the 'LD' of the order code to 'LDD', so for example, 'LD-F1ONA' becomes 'LDD-F1ONA', or:

Add the item LD-DC to your order.



**Flush or End Mounting**

The sign is supplied as standard so that it can be mounted flush to a wall, e.g. for the 'TX' & 'REH' sign shown below. However, a mounting kit is available, LD-KE1, to mount the sign perpendicular to a wall, e.g. above a door, such as the ON AIR sign shown.



LD-KE1 End Mounting Kit For 40cm Or 20cm Flush Mounting Signs.



End Mounting 40cm Single Sign (Created From Single Flush Mounting LD-40F1ONA Sign & LD-KE1 kit).



LD-40F2TX-REH Flush Mounting 40cm Twin Sign.



LD-40F2ONA-SIL Twin 'ON AIR' & 'SILENCE' sign.

**Simple Installation**

The signs are supplied with a 6V DC power supply. Simply wire up your control signal(s) and DC input to the 'screw terminal block' inside the sign, route the cables through the integral cable clamp and mount the unit on the wall.

An installation tool, the LD-IT can be used to hold the sign in place on the wall mount whilst you wire it up.

The display mode and colour options are set-up using a separate remote control, the LD-RPC.



LD-IT LED Sign End Mounting Installation Tool.

**LD-RPC SignalLED Remote Programming Controller**

The SignalLED signs are preconfigured to display certain colours when the control inputs are active. Information on the colours shown can be found on the Sonifex website. To vary the colours and switching modes, the LD-RPC Remote Programming Controller must be used. This allows a simple way of programming any sign using a hand-held remote control.

Please note that the control is sold separately and one LD-RPC can program multiple signs.



Standard DC Power Supply with Plug Adapters.

**Custom Signs**

Although a range of standard signs is supported, custom signs, for example with your company name or logo, can be produced for a nominal setup fee. Contact Sonifex with your requirements.



Custom Single Flush Mounting 40cm Sign.

**Examples Of Custom Signs**

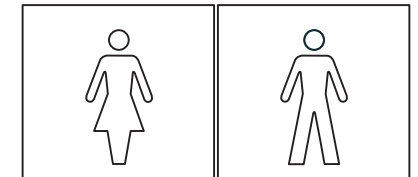



**How to Order**

Just select the name of the sign from the list below.



LD-40F1ONA Single Flush Mounting 40cm 'ON AIR' Sign.



LD-40F1MCL Single Flush Mounting 40cm 'MIC LIVE' Sign.



LD-40F1PHN Single Flush Mounting 40cm 'PHONE' Sign.



LD-40F1TRF Single Flush Mounting 40cm 'TRAFFIC FLAG ON' Sign.



LD-40F1ADB Single Flush Mounting 40cm 'AD BREAK' Sign.



LD-40F1REH Single Flush Mounting 40cm 'REHEARSAL' Sign.



LD-40F1DOR Single Flush Mounting 40cm 'DOOR' Sign.



LD-40F1OBT Single Flush Mounting 40cm 'OBIT' Sign.



LD-40F1NOE Single Flush Mounting 40cm 'NO ENTRY' Sign.



LD-40F1EXIT Single Flush Mounting 40cm 'EXIT' Sign.



LD-40F1SIL Single Flush Mounting 40cm 'SILENCE PLEASE' Sign.



LD-40F1MET Single Flush Mounting 40cm 'MEETING IN PROGRESS' Sign.



LD-40F1INT Single Flush Mounting 40cm 'INTERVIEW IN PROGRESS' Sign.

**Specification For SignalLED**

Power Input:	5-7V DC	40cm Sign: 500mA max
Input Connector:	4 way screw terminal block	
Control Inputs:	2 x pull-down to 0V	
Dimensions (Perspex):	Small Single: 20cm (W) x 8cm (H) Large Single: 40cm (W) x 8cm (H)	
Dimensions (Boxed 20cm):	40cm (W) x 20cm (D) x 11cm (H) 15.7" (W) x 7.9" (D) x 4.3" (H)	
Dimensions (Boxed 40cm):	60cm (W) x 20cm (D) x 11cm (H) 23.6" (W) x 7.9" (D) x 4.3" (H)	
Weight (20cm):	Nett: 0.35kg	Gross: 0.85kg
	Nett: 0.8lb	Gross: 1.9lb
Weight (40cm):	Nett: 0.55kg	Gross: 1.15kg
	Nett: 1.2lb	Gross: 2.6lb

**Equipment Type**

**Single Flush Mounting Signs (40cm):**

LD-40F1REC	40cm 'RECORD' Sign
LD-40F1ONA	40cm 'ON AIR' Sign
LD-40F1MCL	40cm 'MIC LIVE' Sign
LD-40F1PHN	40cm 'PHONE' Sign
LD-40F1TRF	40cm 'TRAFFIC FLAG ON' Sign
LD-40F1ADB	40cm 'AD BREAK' Sign
LD-40F1REH	40cm 'REHEARSAL' Sign
LD-40F1DOR	40cm 'DOOR' Sign
LD-40F1OBT	40cm 'OBIT' Sign
LD-40F1NOE	40cm 'NO ENTRY' Sign
LD-40F1EXIT	40cm 'EXIT' Sign
LD-40F1SIL	40cm 'SILENCE PLEASE' Sign
LD-40F1MET	40cm 'MEETING IN PROGRESS' Sign
LD-40F1INT	40cm 'INTERVIEW IN PROGRESS' Sign

**Twain Flush Mounting Signs (2 x 20cm):**

LD-40F2TX-REH	2 x 20cm 'TX' & 'REH' Sign
LD-40F2ONA-MCL	2 x 20cm 'ON AIR' & 'MIC LIVE' Sign

**Single Flush Mounting Signs (20cm):**

LD-20F1REC	20cm 'RECORD' Sign
LD-20F1ONA	20cm 'ON AIR' Sign
LD-20F1MCL	20cm 'MIC LIVE' Sign

**Mounting Kits:**

LD-KE1	End Mounting Kit For 40cm Or 20cm Flush Mounting Signs
LD-KC1	Ceiling Mounting Kit For 40cm Or 20cm Flush Mounting Signs
LD-IT	LED Sign End Mounting Installation Tool



## Index

Stock Code	Description	Page No
<b>3</b>		
3G, HD & SD-SDI	Embedders & De-Embedders	35
<b>A</b>		
Alternative Button Text		200
<b>C</b>		
CM-AESB3	Single 3 Way Passive AES3ID Splitter With BNC Connectors	146
CM-AESX3	Single 3 Way AES/EBU Passive Splitter With XLR Connectors	145
CM-BH4W	Belt-Pack 4-Wire Headphone Amp	224
CM-BHA	Belt Pack Headphone Amplifier With Limiter & Loudspeaker	225
CM-CU1	Commentator Unit 1 Commentator & Line Input	216
CM-CU21	Commentator Unit 2 Commentators & 1 Guest	220
CM-GM1	Professional Gooseneck Condenser Microphone	215
CM-MS3	Single 3 Way Passive Microphone Splitter	147
CM-TB8	8 Channel Talkback Control Unit	210
CM-TB8G	Talkback Control Unit, CM-TB8 with CM-TBG Dual GSM Interface	214
CM-TB8T	Talkback Control Unit, CM-TB8 with CM-TBT Dual PSTN Telephone Hybrid	213
CM-TBU	Line Powered Telephone Balance Unit	234
CM-TLL	Line Powered Telephone Line Listen Unit	235
Contents		iii
<b>D</b>		
DHY-03, DHY-03S & DHY-03T	Digital Telephone Hybrids	238
DHY-03EC	Automatic Digital Telephone Balance Unit Eurocard	241
DHY-04G	Single Automatic GSM Hybrid, AES/EBU & Analogue I/O With Ethernet	244
DHY-04HD	Single Automatic HD Voice & GSM Hybrid, AES/EBU & Analogue I/O With Ethernet	246
DHY-04	Single Automatic Digital TBU, AES/EBU & Analogue I/O With Ethernet	242

Stock Code	Description	Page No
<b>F</b>		
Free Sonifex Switchboard Software - Remote Control of DHY-04/G/HD Hybrids		249
<b>H</b>		
HY-03, HY-03S & HY-03T	Analogue Telephone Hybrids	236
<b>I</b>		
IP Streamers		251
<b>K</b>		
Key to Symbols: i		
<b>M</b>		
Mentor Time-Server		165
Monitor Speaker Stands		208
<b>N</b>		
Net-Log Network Audio Logger		160
<b>P</b>		
PC-AD2	2 Stereo Analogue I/O & 2 Stereo AES-3 I/O PCIe Half Height Sound Card	150
PC-AM6-32	AM Radcap PCIe Card (6 to 32 Channels)	157
PC-AUR44	Auricon 4.4 PCIe Analogue Sound Card	154
PC-DAB1-4	Multi-Ensemble DAB+/DAB Radcap PCIe Card	155
PC-DIG4	Digitorc 4, 4 Stereo AES-3 I/O PCIe Sound Card	153
PC-FLS8	Flashlog 8 Audio & Radio Capture Logging Software	166

Stock Code	Description	Page No
PC-FM6-32	FM Radcap PCIe Card (6 to 32 Channels)	156
PC-RACK	Industrial PC Racks for Audio Logging	169
Pro Audio Streamers		251
Professional Sound Cards		150
PS-AMP	IP to Speakers Streaming Decoder	256
PS-PLAY	IP to Audio Streaming Decoder	254
PS-SEND	Audio to IP Streaming Encoder	252
<b>R</b>		
Radio Capture Cards		155
RB-ADDA2	A/D and D/A Converter, 24 bit 192kHz	46
RB-ADDA	Combined A/D and D/A Converter	44
RB-AEC	Acoustic Echo Canceller	62
RB-AES4B3	Quad 3 Way Passive AES3ID Splitter BNC Connectors	104
RB-AES4X3	Quad 3 Way AES/EBU Splitter XLR Connectors	105
RB-BL2	Single Stereo Bi-Directional Matching Converter	82
RB-BL4	Dual Stereo Bi-Directional Matching Converter	83
RB-DA4x5	4 Input, 4 x 5 Output Distribution Amplifier/Mixer	92
RB-DA6	6 Way Stereo Distribution Amplifier	87
RB-DA6G	6 Way Stereo Distribution Amplifier With Output Gain Control	88
RB-DA6P	6 Way Stereo Distribution Amplifier With Phoenix Connectors	89
RB-DA6R	6 Way Stereo Distribution Amplifier With RJ45 Connectors	90
RB-DA6RG	6 Way Stereo Distribution Amplifier With RJ45 Connectors & Output Gain Control	91
RB-DA24MD	24 Way Mono Audio Distribution Amplifier	102
RB-DAC1	Digital To Analogue Converter	52
RB-DD4	4 Channel Digital Audio Delay	60
RB-DDA6A-2P	6 Way Stereo AES/EBU Digital Distribution Amplifier with Dual Power Supplies	95
RB-DDA6A3	6 Way Stereo AES3ID Digital Audio Distribution Amplifier	99
RB-DDA6A	6 Way Stereo AES/EBU Digital Distribution Amplifier	94
RB-DDA6S	6 Way Stereo S/PDIF Digital Distribution Amplifier	96
RB-DDA6W-2P	6 Way Word Clock Distribution Amplifier with Dual Power Supplies	98
RB-DDA6W	6 Way Word Clock Distribution Amplifier	97

Stock Code	Description	Page No	Stock Code	Description	Page No	Stock Code	Description	Page No
RB-DDA22	Digital Audio Distribution Amplifier With Multiple Outputs	100	RB-SC2	Dual Sample Rate Converter	50	RM-E1X	Reference Monitor Dolby E & Dolby® Digital Decoder XLR AES Expansion Card	13
RB-DHD6	Digital 6 Way Stereo Headphone Distribution Amplifier	112	RB-SD1IP	Silence Detection Unit With Ethernet & USB	66	RM-HD1	Reference Monitor 3G/HD/SD-SDI Expansion Card	11
RB-DMA2	Dual Digital Microphone Amplifier	130	RB-SD1	Silence Detection Unit	64	RM-HDE1	Reference Monitor HD-SDI & Dolby® E & Dolby® Digital Expansion Card	12
RB-DMX4	4 x 4 Channel Digital Audio Mixer/Router	120	RB-SL2	Twin Mono, Or Stereo, Limiter	133	RM-M1F53	1 Stereo 53-Segment Meter, Free-Standing	19
RB-DS2R	Remote Switch Panel For RB-DS2	55	RB-SM1	Single Stereo To Mono Converter	134	RM-M1F106	1 Stereo 106-Segment Meter, Free-Standing	21
RB-DS2	Stereo Delay Synchroniser & Time-Zone Delay	56	RB-SM2	Dual Stereo To Mono Converter	135	RM-M1R53	1 Stereo 53-Segment Meter, Rack-Mount	19
RB-DSD1	Digital Silence Detection Unit	68	RB-SS10	10 Way Stereo Analogue Source Selector/Mixer	114	RM-M1R106	1 Stereo 106-Segment Meter, Rack-Mount	21
RB-DSD8	8 Channel Silence Switcher	71	RB-SSML1	Mic/Line Source Selector with Compressor/Limiter	122	RM-M2F53	2 Stereo 53-Segment Meters, Free-Standing	20
RB-DSS10	10 Way Stereo Digital Source Selector	116	RB-TGHD(B or X)	Multi-Channel HD Tone Generator	142	RM-M2R53	2 Stereo 53-Segment Meters, Rack-Mount	20
RB-FS42	Audio Failover Switcher, 4 Main I/O, 2 Standby I/O	74	RB-UL1	Single Stereo Unbalanced To Balanced Converter	78	RM-M2R106	2 Stereo 106-Segment Meters, Rack-Mount	22
RB-FS82	Audio Failover Switcher, 8 Main I/O, 2 Standby I/O	76	RB-UL2	Dual Stereo Unbalanced To Balanced Converter	79	RM-M4R53	4 Stereo 53-Segment Meters, Rack-Mount	20
RB-HD1	Stereo Headphone Amplifier With VCA Volume Control	109	RB-UL4	Quad Stereo Unbalanced To Balanced Converter	80	RM-MC1L	Monitor Controller, Single Stereo Input & Output With Light Control	24
RB-HD2	Dual Stereo Headphone Amplifier	110	RB-VHCMA4	3G/HD/SD-SDI Embedder & De-Embedder 4 Channel Analogue I/O	40	RM-MC4L	Monitor Controller, 4 Stereo Inputs, 1 Stereo Output With Light Control	25
RB-HD6	6 Way Stereo Headphone Distribution Amplifier	111	RB-VHCMD16	3G/HD/SD-SDI Embedder & De-Embedder 16 Channel Digital I/O	42	RM-MC51L	Monitor Controller, 5.1 Stereo Inputs & Outputs With Light Control	26
RB-IPE	IP Extender for GPIO & Analogue Control Signals	140	RB-VHDA2x4	3G/HD/SD-SDI 2 Input, 8 Output Video Distribution Amplifier	32	RM-MCL	Monitor Light Controller, 3 Button, TX-STANDBY-REH	27
RB-LC3	3 Way Light/Power Controller	136	RB-VHDA8	3G/HD/SD-SDI 1 Input, 8 Output Video Distribution Amplifier	34			
RB-LI2	Stereo Line Isolation Unit	85	RB-VHDM8	3G/HD/SD-SDI De-Embedder, 8 Channel Analogue Output	36			
RB-LU4	Quad Stereo Balanced To Unbalanced Converter	81	RB-VHEMA8	3G/HD/SD-SDI Embedder, 8 Channel Analogue Inputs	38			
RB-MA1	Single Microphone Amplifier	127		Redbox Audio & Video Interfaces	30			
RB-MA2	Dual Microphone Amplifier	128		Reference Monitor Controllers	23			
RB-MA2G	Dual Microphone Amplifier Gain Controls	129		Reference Monitor Meters	18			
RB-ML2	Stereo Microphone & Line Level Limiter	132		Reference Monitor Rackmount Audio Monitors	2			
RB-MM1	Mix-Minus Generator	137	RM-2S4	Reference Monitor, 2 LED Meters & 4 Stereo Inputs	4	S0	Radio Broadcasting On-Air Mixer	172
RB-MS4X3	Quad 3 Way Passive Microphone Splitter	106	RM-2S10	Reference Monitor, 2 LED Meters, 10 Stereo Analogue & 10 Stereo Digital Inputs	5	S1	Radio Broadcast On-Air Mixer	176
RB-MSP6	6 Way +48V Phantom Power Supply	108	RM-4C8-HD1	Reference Monitor, 4 LED Meters, 8 Channel Inputs & Dual Source Selectors With RM-HD1 3G/HD/SD-SDI De-Embedder Card	9	S2-05	Chassis	201
RB-MTV1	Contribution Voiceover Monitor With Talkback	138	RM-4C8-HDE1	Reference Monitor, 4 LED Meters, 8 Channel Inputs & Dual Source Selectors With De-Embedder & Dolby Decoder Card	10	S2-7SS	Script Space	202
RB-OA3	3 Studio On-Air Switcher	124	RM-4C8	Reference Monitor, 4 LED Meters, 8 Channel Inputs & Dual Source Selectors	7	S2-10	Chassis	201
RB-OA3C	Expansion Unit Cable For RB-OA3	126	RM-CA2	Confidence Monitor, 2 LED Meters & 2 Analogue Stereo Inputs	14	S2-10SS	Script Space	202
RB-OA3R	Remote Switcher Panel For RB-OA3	126	RM-CAD8	Confidence Monitor, 2 LED Meters, 2 Analogue & 6 Digital Stereo Inputs	16	S2-15	Chassis	201
RB-PA2	Dual Stereo RIAA Phono Amplifier	84	RM-E1B	Reference Monitor Dolby E & Dolby® Digital Decoder BNC Expansion Card	13	S2-20	Chassis	201
RB-PD2	Stereo Profanity Delay	58				S2-25	Chassis	201
RB-PLI6	6 Way Mono Passive Line Isolation Unit	86				S2-30	Chassis	201
RB-PMX4	10 Input, 4 Output Analogue Pre-set Mixer	118				S2-BI	Bus Interlink Cable	204
RB-SC1	Sample Rate Converter	48				S2-C6S5	6 Way Stereo Source Select Channel with EQ	189
						S2-CB	Blank Channel	192



Stock Code	Description	Page No
S2-CDAS	Dual Stereo Line Channel & S2-CDASE Dual Stereo Line Channel with EQ	188
S2-CDS	Digital Dual Stereo Channel	187
S2-CDSE	Digital Dual Stereo Channel with EQ	188
S2	Chassis Sizes	201
S2-CML	Mic/Line Channel	184
S2-CMM	Mic/Mic Channel	184
S2-CS	Dual Stereo Line Channel & S2-CSE Dual Stereo Line Channel with EQ	185
S2-CSG	Stereo Line & Gram Channel & S2-CSGE Stereo Line & Gram Channel with EQ	186
S2-CSMM	Stereo Mix Minus Channel	190
S2-CT	Telco Channel	191
S2	Digital I/O Analogue Radio Broadcast Mixer	182
S2	Input Channels	183
S2-M6S5	Meterbridge 6 Way Source Select Panel	199
S2-MB1-5	Meterbridge Blanking Plates 1-5	200
S2	Meterbridge Modules	197
S2	Mixer Placement In Furniture	203
S2-ML53	Meterbridge LED Meter Panel	198
S2-ML	Meterbridge Loudspeaker Monitor Panel	199
S2-MPH	Meterbridge Phase Meter Panel	198
S2-MPPM	Meterbridge PPM Meter Panel	198
S2-MSB1	S2 Meterbridge Switch Panel With 1 Button	199
S2-MSB3	S2 Meterbridge Switch Panel With 3 Buttons	199
S2-MTB6	Meterbridge 6 Way Talkback Panel	200
S2-MTBS	Meterbridge Station Master Talkback Panel	200
S2-MT	Meterbridge Dual Timer Panel	199
S2-MVU	Meterbridge VU Meter Panel	198
S2-ODA	Digital AUD Output Channel &	196
S2-ODAF	Digital AUD Output Channel with Master Fader	196
S2-ODP	Digital PGM Output Channel &	195
S2-ODPF	Digital PGM Output Channel with Master Fader	195
S2-OMC	Control Room Monitor Channel	193
S2-OMS	Studio Monitor Channel	194



Sonifex Production - Manufactured in the United Kingdom.

Stock Code	Description	Page No
S2	Output Channels	193
S2-PG	Penny & Giles Conductive Plastic Fader	196
S2-PSU	Power Supply	204
S2-PSUS	Dual Power Supply Switcher	205
S2	Without Meterbridge	197
SignalLED	Range of LED Signs	260
S2	Synchronisation Add-On Boards	54



Sonifex Product Testing.

Stock Code	Description	Page No
TB-6D & TB-6R	6 Way Talkback Intercoms	226
	The Best Telephone Hybrid in the World Just Got Better!	243
W	What Is A Telephone Hybrid?	233



# **SONIFEX**

[www.sonifex.co.uk](http://www.sonifex.co.uk)

---

**UK Office:**

**Sonifex Ltd**

61 Station Road, Irthlingborough,

Northants, NN9 5QE, UK

Tel: +44 (0) 1933 650700

Fax: +44 (0) 1933 650726

Email: [sales@sonifex.co.uk](mailto:sales@sonifex.co.uk)

**Australian Office:**

**Sonifex Pty Ltd**

12/6 Leighton Place,

Hornsby NSW 2077, Australia

Tel: +61 (2) 9987 0499

Fax: +61 (2) 9476 4950

Email: [sales@sonifex.com.au](mailto:sales@sonifex.com.au)