



HANDBOOK

Confidence Monitors

RM-CA2

Confidence Monitor, 2 LED Meters & 2 Analogue Stereo Inputs

RM-CAD8

Confidence Monitor, 2 LED Meters, 2 Analogue & 6 Digital Stereo Inputs



Manufacturers of audio & video
products for radio & TV broadcasters

SONIFEX

For the latest Sonifex handbook information please visit the
Sonifex website at www.sonifex.co.uk

This handbook is for use with the following product:

RM-CA2 Confidence Monitor, 2 LED Meters & 2 Analogue Stereo Inputs

RM-CAD8 Confidence Monitor, 2 LED Meters, 2 Analogue & 6 Digital Stereo Inputs

Stock Code: 30-229

Revision 2.01, February 2020

©Sonifex Ltd, 2020

All Rights Reserved

Sonifex Ltd, 61, Station Road, Irthlingborough,
Northants, NN9 5QE, England.

Tel: +44 (0)1933 650 700

Fax: +44 (0)1933 650 726

Email: sales@sonifex.co.uk

Website: <https://www.sonifex.co.uk>

Information in this document is subject to change without notice and does not represent a commitment on the part of the vendor. Sonifex Ltd shall not be liable for any loss or damage whatsoever arising from the use of information or any error contained in this manual.

No part of this manual may be reproduced or transmitted in any form or by any means, electronic or mechanical, including photocopying, recording, information storage and retrieval systems, for any purpose other than the purchaser's personal use, without the express written permission of Sonifex Ltd. Unless otherwise noted, all names of companies, products and persons contained herein are part of a completely fictitious adaptation and are designed solely to document the use of Sonifex product.

Contents

Product Warranty - 2 Year Extended	i
Sonifex Warranty & Liability Terms & Conditions	i
Unpacking Your Product	ii
Repairs & Returns	iii
CE Conformity	iii
Safety & Installation of Mains Operated Equipment	iii
Voltage Setting Checks	iii
Fuse Rating	iii
Power Cable & Connection	iii
WEEE Directive	iv
Atmosphere/Environment	iv
Confidence Monitors Introduction	1
Features Summary	2
1. RM-CA2 Confidence Monitor, 2 LED Meters & 2 Analogue Stereo Inputs	3
System Block Diagram	4
2. RM-CAD8 Confidence Monitor, 2 LED Meters, 2 Analogue & 6 Digital Stereo Inputs	4
Front Panel Indicators & Controls	5
Rear Panel Connections & Operation	7
DIPSwitch Settings	8
Technical Specification RM-CA2 & RM-CAD8	10

Figures

Fig 1-1: RM-CA2 Confidence Monitor Front Panel	3
Fig 1-2: RM-CAD8 Confidence Monitor Front Panel	4
Fig 1-3: Confidence Monitor Block Diagram	4
Fig 1-4: RM-CA2 Front Panel Controls	5
Fig 1-5: RM-CAD8 Front Panel Controls	5
Fig 1-6: RM-CA2 Source Selector Button	5
Fig 1-7: RM-CAD8 Source Selector Button	5
Fig 1-8: RM-CA2 & RM-CAD8 Meters & Phase Error LED	5
Fig 1-9: RM-CA2 Left Level or Balance Control and Power On Indicator	6
Fig 1-10: RM-CAD8 Right Level or Stereo Level Control	6
Fig 1-11: RM-CA2 & RM-CAD8 Meters & Phase Error LED	6
Fig 1-12: Confidence Monitor RM-CA2 Rear	7
Fig 1-13: Confidence Monitor RM-CAD8 Rear	7
Fig 1-14: DIPSwitch Settings	8

SONIFEX

Register Online for an Extended 2 Year Warranty

As standard, Sonifex products are supplied with a 1 year back to base warranty.

If you register the product online, you can increase your product warranty to 2 years and we can also keep you informed of any product design improvements or modifications.

Product: _____

Serial No: _____

To register your product, please go online to www.sonifex.co.uk/register

SONIFEX

Sonifex Limited • 61 Station Road • Irthlingborough • Northamptonshire • NN9 5QE • United Kingdom
Tel: +44 (0)1933 650 700 • Fax: +44 (0)1933 650 726 • Email: technical.support@sonifex.co.uk • Internet: www.sonifex.co.uk

Product Warranty - 2 Year Extended

As standard, Sonifex products are supplied with a 1 year back to base warranty. In order to register the date of purchase and so that we can keep you informed of any product design improvements or modifications, it is important to complete the warranty registration online. Additionally, if you register the product on the Sonifex website, you can increase your product warranty to 2 years. Go to the Sonifex website at: <http://www.sonifex.co.uk/technical/register/index.asp> to apply for your 2 year warranty.

Note: For your own records the product serial number is recorded on the CE certification page of this handbook.

Sonifex Warranty & Liability Terms & Conditions

1. Definitions

‘the Company’ means Sonifex Ltd and where relevant includes companies within the same group of companies as Sonifex Limited.

‘the Goods’ means the goods or any part thereof supplied by the Company and where relevant includes: work carried out by the Company on items supplied by the Purchaser; services supplied by the Company; and software supplied by the Company.

‘the Purchaser’ means the person or organisation who buys or has agreed to buy the Goods.

‘the Price’ means the Price of the Goods and any other charges incurred by the Company in the supply of the Goods.

‘the Warranty Term’ is the length of the product warranty which is usually 12 months from the date of despatch; except when the product has been registered at the Sonifex website when the Warranty Term is 24 months from the date of despatch.

‘the Contract’ means the quotation, these Conditions of Sale and any other document incorporated in a contract between the Company and the Purchaser.

This is the entire Contract between the parties relating to the subject matter hereof and may not be changed or terminated except in writing in accordance with the provisions of this Contract. A reference to the consent, acknowledgement, authority or agreement of the Company means in writing and only by a director of the Company.

2. Warranty

- a. The Company agrees to repair or (at its discretion) replace Goods which are found to be defective (fair wear and tear excepted) and which are returned to the Company within the Warranty Term provided that each of the following are satisfied:
 - i. notification of any defect is given to the Company immediately upon its becoming apparent to the Purchaser;
 - ii. the Goods have only been operated under normal operating conditions and have only been subject to normal use (and in particular the Goods must have been correctly connected and must not have been subject to high voltage or to ionising radiation and must not have been used contrary to the Company’s technical recommendations);
 - iii. the Goods are returned to the Company’s premises at the Purchaser’s expense;
 - iv. any Goods or parts of Goods replaced shall become the property of the Company;
 - v. no work whatsoever (other than normal and proper maintenance) has been carried out to the Goods or any part of the Goods without the Company’s prior written consent;

- vi. the defect has not arisen from a design made, furnished or specified by the Purchaser;
 - vii. the Goods have been assembled or incorporated into other goods only in accordance with any instructions issued by the Company;
 - viii. the defect has not arisen from a design modified by the Purchaser;
 - ix. the defect has not arisen from an item manufactured by a person other than the Company. In respect of any item manufactured by a person other than the Company, the Purchaser shall only be entitled to the benefit of any warranty or guarantee provided by such manufacturer to the Company.
- b. In respect of computer software supplied by the Company the Company does not warrant that the use of the software will be uninterrupted or error free.
- c. The Company accepts liability:
- (i) for death or personal injury to the extent that it results from the negligence of the Company, its employees (whilst in the course of their employment) or its agents (in the course of the agency);
 - (ii) for any breach by the Company of any statutory undertaking as to title, quiet possession and freedom from encumbrance.
- d. Subject to conditions (a) and (c) from the time of despatch of the Goods from the Company's premises the Purchaser shall be responsible for any defect in the Goods or loss, damage, nuisance or interference whatsoever consequential economic or otherwise or wastage of material resulting from or caused by or to the Goods. In particular the Company shall not be liable for any loss of profits or other economic losses. The Company accordingly excludes all liability for the same.
- e. At the request and expense of the Purchaser the Company will test the Goods to ascertain performance levels and provide a report of the results of that test. The report will be accurate at the time of the test, to the best of the belief and knowledge of the Company, and the Company accepts no liability in respect of its accuracy beyond that set out in Condition (a).
- f. Subject to Condition (e) no representation, condition, warranty or other term, express or implied (by statute or otherwise) is given by the Company that the Goods are of any particular quality or standard or will enable the Purchaser to attain any particular performance or result, or will be suitable for any particular purpose or use under specific conditions or will provide any particular capacity, notwithstanding that the requirement for such performance, result or capacity or that such particular purpose or conditions may have been known (or ought to have been known) to the Company, its employees or agents.
- g. (i) To the extent that the Company is held legally liable to the Purchaser for any single breach of contract, tort, representation or other act or default, the Company's liability for the same shall not exceed the price of the Goods.
(ii) The restriction of liability in Condition (g)(i) shall not apply to any liability accepted by the Seller in Condition (c).
- h. Where the Goods are sold under a consumer transaction (as defined by the Consumer Transactions (Restrictions on Statements) Order 1976) the statutory rights of the Purchaser are not affected by these Conditions of Sale.

Unpacking Your Product

Each product is shipped in protective packaging and should be inspected for damage before use. If there is any transit damage take pictures of the product packaging and notify the carrier immediately with all the relevant

details of the shipment. Packing materials should be kept for inspection and also for if the product needs to be returned.

The product is shipped with the following equipment so please check to ensure that you have all of the items below. If anything is missing, please contact the supplier of your equipment immediately.

Item	Quantity
Product unit	1
IEC mains lead fitted with moulded mains plug	1
Handbook and warranty card	1
GSM stubby antenna	1

If you require a different power lead, please let us know when ordering the product.

Repairs & Returns

Please contact Sonifex or your supplier if you have any problems with your Sonifex product. Email technical.support@sonifex.co.uk for the repair/upgrade/returns procedure, or for support & questions regarding the product operation.

CE Conformity

The products in this manual comply with the essential requirements of the relevant European health, safety and environmental protection legislation.

The technical justification file for this product is available at Sonifex Ltd.

The declaration of conformity can be found at:
<https://www.sonifex.co.uk/declarations>

Safety & Installation of Mains Operated Equipment

There are no user serviceable parts inside the equipment. If you should ever need to look inside the unit, always disconnect the mains supply before removing the equipment covers. The cover is connected to earth by means of the fixing screws. It is essential to maintain this earth/ground connection to ensure a safe operating environment and provide electromagnetic shielding.

Voltage Setting Checks

Ensure that the machine operating voltage is correct for your mains power supply by checking the box in which your product was supplied. The voltage is shown on the box label. The available voltage settings are 115V, or 230V. Please note that all products are either switchable between 115V and 230V, or have a universal power supply.

Fuse Rating





The product is supplied with a single fuse in the live conducting path of the mains power input. For reasons of safety it is important that the correct rating and type of fuse is used. Incorrectly rated fuses could present a possible fire hazard, under equipment fault conditions. The active fuse is fitted on the outside rear panel of the unit.

Power Cable & Connection

An IEC power connector is supplied with the product which has a moulded plug attached.

The mains plug or IEC power connector is used as the disconnect device. The mains plug and IEC power connector shall remain readily operable to disconnect the apparatus in case of a fault or emergency.

The mains lead is automatically configured for the country that the product is being sent to, from one of:

Territory	Voltage	IEC Lead Type	Image
UK & Middle East	230V	UK 3 pin to IEC lead	
Europe	230V	European Schuko round 2 pin to IEC lead	
USA, Canada and South America	115V	3 flat pin to IEC lead	
Australia & New Zealand	230V	Australasian 3 flat pin to IEC lead	

Connect the equipment in accordance with the connection details and before applying power to the unit, check that the machine has the correct operating voltage for your mains power supply.

This apparatus is of a class I construction. It must be connected to a mains socket outlet with a protective earthing connection.

Important note: If there is an earth/ground terminal on the rear panel of the product then it must be connected to Earth.

WEEE Directive



The Waste Electrical and Electronic Equipment (WEEE) Directive was agreed on 13 February 2003, along with the related Directive 2002/95/EC on Restrictions of the use of certain Hazardous Substances in electrical and electronic equipment (RoHS). The Waste Electrical and Electronic Equipment Directive (WEEE) aims to minimise the impacts of electrical and electronic equipment on the environment during their life times and when they become waste. All products manufactured by Sonifex Ltd have the WEEE directive label placed on the case. Sonifex Ltd will be happy to give you information about local organisations that can reprocess the product when it reaches its “end of use”, or alternatively all products that have reached “end of use” can be returned to Sonifex and will be reprocessed correctly free of charge.

Atmosphere/Environment

This apparatus should be installed in an area that is not subject to excessive temperature variation (<0°C, >50°C), moisture, dust or vibration.

This apparatus shall not be exposed to dripping or splashing, and no objects filled with water, such as vases shall be placed on the apparatus.



Confidence Monitors Introduction

The Confidence Monitor Range is a series of rack-mount audio monitors, combining the latest DSP technology with outstanding audio enclosure design to produce monitors of the highest standards with exceptional sound quality, a comprehensive feature set and good looks in the rack.

Detail In The Design

In the design of the product, every care has been taken to ensure the best and most accurate reproduction of the audio sources.

In a 1U rack, the propagation of high power sound waves in such a small enclosure could have a tendency to produce rattles or move components, but the Confidence Monitors have been designed to ensure that their audio performance is not compromised.

Anti-Vibration

A welded, sealed and painted steel case with milled aluminium fascia provides exceptional rigidity and has been used to ensure that there are no extraneous metallic rattles. The lid is sealed with extensive thin foam cut-outs to provide damping to the lid and multi-point screw fixings are used to ensure lid rigidity.

Accurate Sound System

The speaker system comprises a three-way arrangement with two mid/high frequency speakers providing excellent stereo imaging and a separately driven, forward facing, dual magnet, mono bass driver.

Custom-moulded, profiled, HF enclosures are used to minimise standing waves and eliminate response peaks, and acoustic damping in the HF enclosures is used to reduce colouration, effectively creating a separate, sealed, infinite-baffle enclosure for each driver.

Each of the drivers is magnetically shielded so that the monitors are perfectly safe to use near CRTs and TFT displays and each speaker uses a separate, highly efficient class-D switching amplifier.

Even cable lengths to and from the speaker enclosures have been kept short to reduce any potential microphonic induction.

DSP Based Design

The use of a modern electronic architecture allows a much better audio performance to be realised. The DSP-based, 3rd-order active crossover provides perfect separation between mid-range and bass sounds.

A DSP-based electronic equalisation is used to flatten the frequency response and the fast-attack DSP loudspeaker limiter protects the drivers from overload damage.

Features Summary

- Anti-vibration steel case.
- Sealed lid with foam cut-outs to dampen lid.
- Multi-point screw fixings ensure lid rigidity.
- Rear connector ports sealed with foam.
- Glue used on components which could move, or vibrate.
- Accurate 3-way speaker system.
- Two mid/high frequency speakers provide excellent stereo imaging.
- Separately driven, forward facing, dual magnet, mono bass driver.
- Custom-moulded, profiled, HF enclosures minimise standing waves.
- Acoustic damping in the HF enclosures reduces colouration.
- Separate, sealed, infinite-baffle enclosure for each driver.
- Magnetically shielded drivers so that the monitors are perfectly safe to use near CRTs and TFT displays.
- Separate, highly efficient class-D switching amplifier for each speaker.
- Short, even cable lengths to and from the speaker enclosures to reduce any potential microphonic induction.
- DSP based design allows better audio performance to be realised.
- Active crossover provides perfect separation between mid-range and bass sounds.
- A universal power supply ensures global voltage operation without adjustment.

1. RM-CA2 Confidence Monitor, 2 LED Meters & 2 Analogue Stereo Inputs

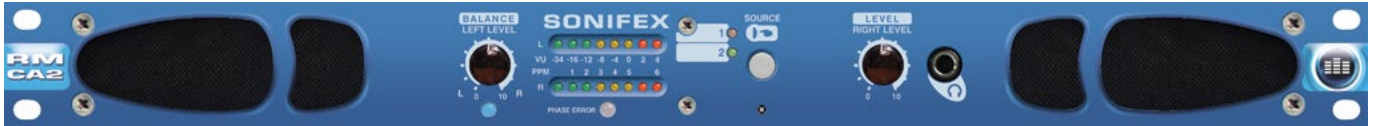

Fig 1-1: RM-CA2 Confidence Monitor Front Panel

The **RM-CA2** is a 1U rack-mount unit offering quality loudspeaker monitoring and 2 channel metering of two stereo analogue audio sources. Input 1 has stereo balanced Neutrik™ XLRs and Input 2 has both stereo balanced Neutrik™ XLRs and stereo unbalanced RCA phono connectors, these inputs are mixed together in the analogue domain. The balanced analogue inputs can be wired unbalanced if required.

Sources are selected via a front panel push-button button, with clear LED indication of the current source.

A rear panel DIP switch setting allows the unit to monitor either:

- Stereo signals, with the two front panel control knobs acting as stereo volume and balance control, to alter the stereo imaging of the left and right channels, or
- Dual mono signals, with the two front panel control knobs acting as left and right volume controls.

There is a front panel headphone socket which responds to the volume controls and the headphone socket automatically mutes the internal loudspeakers when a plug is inserted.

A pair of line-level analogue audio outputs follow the selected source at the selected level, or optionally at 10dB lower (if using the unbalanced input), set via rear-panel DIP switch 5.

The level of the chosen source is shown on an 8 segment LED bar-graph display with PPM and VU scales indicated. The bar-graph can optionally be lowered by 10dB (if using input 2), set via rear-panel DIP switch 1.

A single phase error LED indicates phase error conditions.

The three-way loudspeaker system is fed via a DSP-based active crossover and a trio of highly efficient Class-D amplifiers. Careful attention to driver selection, materials and case design, plus active DSP equalisation, has ensured a flat response and outstanding reproduction from such a shallow unit. A protective limiter prevents damage to the loudspeakers under overload conditions

The RM-CA2 operates from global mains voltages (85-264V AC, 47-63Hz) without adjustment.

2. RM-CAD8 Confidence Monitor, 2 LED Meters, 2 Analogue & 6 Digital Stereo Inputs



Fig 1-2: RM-CAD8 Confidence Monitor Front Panel

The **RM-CAD8** has all the features of the RM-CA2 together with the ability to select from an additional 6 stereo digital inputs. As well as the 2 stereo analogue inputs there are also:

- 1 x stereo S/PDIF unbalanced input on RCA phono female.
- 1 x stereo Toslink unbalanced input on an optical connector.
- 4 x stereo AES/EBU balanced inputs on XLR 3 pin female.

The source select button illuminates to indicate loss of synchronisation lock to the incoming digital source.

A sample rate converter on the digital input allow sources of different sample rates to be connected and monitored, between 32kHz and 96kHz. All other features of the unit are identical to the RM-CA2.

System Block Diagram

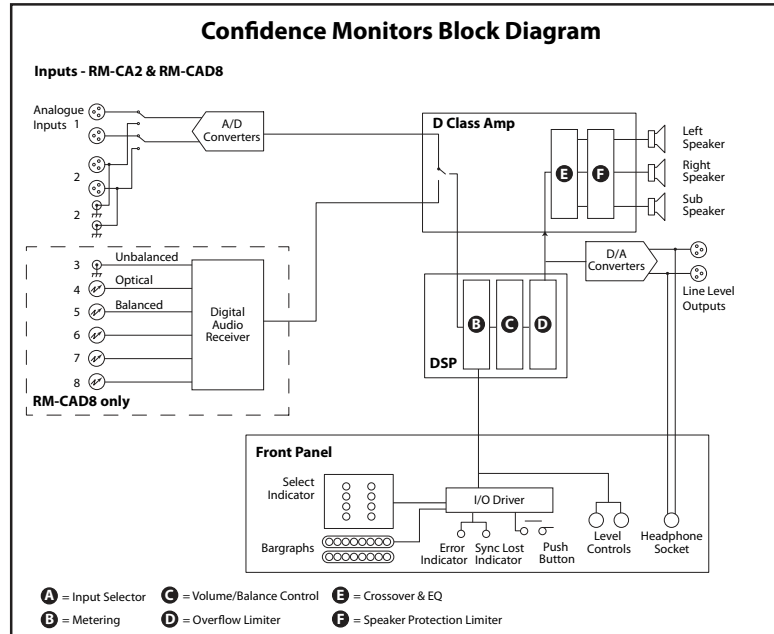

Fig 1-3: Confidence Monitor Block Diagram

Front Panel Indicators & Controls



Fig 1-4: RM-CA2 Front Panel Controls



Fig 1-5: RM-CAD8 Front Panel Controls

Power LED

The POWER LED illuminates whilst internal power is present within the unit. If this indicator is not on, the most likely reason is simply the absence of mains power, but under fault conditions it may also indicate a ruptured mains fuse or a problem with the internal power supply module.

Source Selector

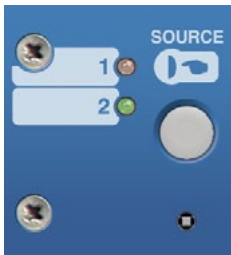

Fig 1-6: RM-CA2 Source Selector Button

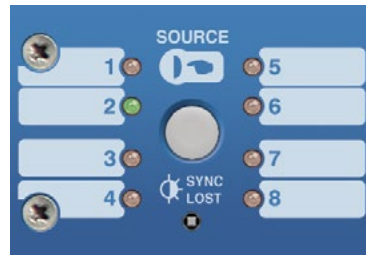

Fig 1-7: RM-CAD8 Source Selector Button

The Source Selector determines which of the two (RM-CA2) or eight (RM-CAD8) stereo audio inputs is routed to the loudspeakers and metering.

Pressing the Source selector button steps sequentially through all input sources. Once the last available source is selected, a further press returns the selection to the first source.

When mains power is removed, the currently selected Source is stored in non-volatile memory and recalled instantly once power is restored.

Sync Lost indicator

On the RM-CAD8 the Sync Lost indicator flashes when one of the following conditions is met. A digital audio input is selected and the digital audio signal is:

- missing,
- has a sample rate outside the acceptable range of the unit,
- contains invalid/non-audio data,
- or is too weak for the receiver to lock on to.

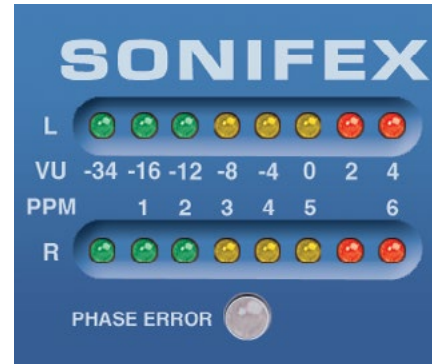

Fig 1-8: RM-CA2 & RM-CAD8 Meters & Phase Error LED

The main meters are twin 8-LED cluster, multicoloured bargraphs, displaying the currently selected stereo audio source. The upper meter displays the left channel and the lower meter the right channel.

Two different characteristics are available for the meters to suit different applications and regional preferences. The active meter characteristic is selected by the setting of DIPSwitch 7 on the rear of the unit.

PHASE Error LED

The Phase Error LED is triggered if the phase difference between the two channels of the currently selected input source remains consistently above 135 degrees.

Level and Balance Controls



Fig 1-9: RM-CA2 Left Level or Balance Control and Power On Indicator

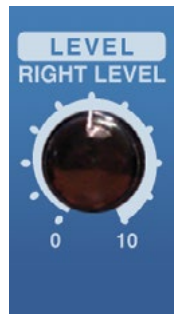

Fig 1-10: RM-CAD8 Right Level or Stereo Level Control

There are two modes of operation for the level and balance controls determined by DIPSwitch 3. When the DIPSwitch is off, the level for each channel is independently controlled.

When the DIPSwitch is on, the level for both channels is set by the right hand potentiometer and the left hand potentiometer acts as a balance control to alter the stereo imaging by $\pm 6\text{dB}$.

The level potentiometers have a range of -52dB to $+18\text{dB}$ gain. Also, moving the potentiometer fully anti-clockwise will mute the output. Position 6 on the level scale (1 o'clock) is a nominal unity gain position.

Headphone Output

The front panel headphone output is a $\frac{1}{4}$ " (6.35mm) stereo jack socket capable of delivering over 80mW into 32Ω - 600Ω professional headphones at full volume. Higher impedance headphones may be used at reduced levels. Lower impedance headphones should not be used.

Inserting a plug into the headphone socket and/or setting DIPSwitch 8 to 'on' automatically mutes the internal loudspeakers.

LIMIT indicators

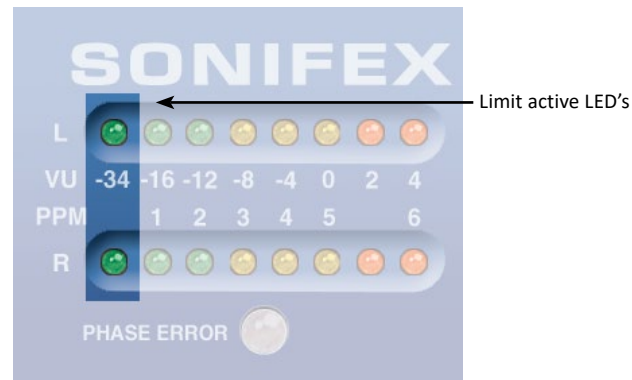

Fig 1-11: RM-CA2 & RM-CAD8 Meters & Phase Error LED

The LIMIT indicators are an additional function of the left hand LED (-34 VU) of the meter scales. When the level potentiometer gain is applied to the incoming signals the resulting signal can exceed the maximum input levels into the D-class amplifier. To avoid clipping or overflow conditions a limiter function is applied. The limiter is applied independently to each channel and has an instantaneous attack with a slow release.

A full-scale digital input signal (0dBFS) corresponds to the maximum analogue input signal level of +18dBu (with no extra input gain applied).

All digital inputs are terminated 110Ω for XLR and 75Ω for phono.

Line Level Audio Outputs

A pair of three-pin male XLR connectors provides a stereo line-level analogue audio output carrying the selected audio Source signal. The XLR pin assignments are as follows:

- Pin 1: Ground
- Pin 2: In-phase signal (“hot”)
- Pin 3: Out-of-phase signal (“cold”)

The signals may be unbalanced without loss of level by linking pins 1 and 3 and taking the unbalanced signal from pin 2.

Mains Power

Power is applied via a standard three-pin IEC male socket. Mains voltages between 85V and 264V AC and frequencies between 47 and 63Hz are accepted without adjustment.

A 2A, 5 x 20mm SB fuse is used. The Earth pin MUST be connected to ensure safety.

Digital Input Termination

All electrical digital audio inputs are terminated. 110Ω for the balanced XLR inputs and 75Ω for the unbalanced S/PDIF inputs.

DIPSwitch Settings

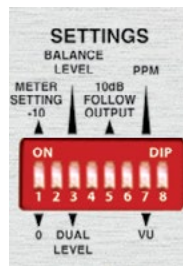

Fig 1-14: DIPSwitch Settings

Reduce Meter Levels by 10dB - DIPSwitch 1

This DIPSwitch is only valid when analogue input 2 is selected and when the switch is on it will reduce the meter levels by 10dB. This switch will mainly be used when the unbalanced inputs are used. In this case a 10dB gain is applied to the signal levels P650 that the inputs from domestic equipment will be increased to levels typically used for professional (unbalanced) equipment. If you wish to monitor the actual level of the unbalanced incoming signals then this switch needs to be on. On the other hand if the balanced input 2 is being used then the switch should be off.

Level/Balance Control Selection - DIPSwitch 3

This DIPSwitch switches the level and balance controls between independent left and right level (switch off) and stereo level and balance control (switch on).

Reduce Output Levels by 10dB - DIPSwitch 5

If the audio output is connected to unbalanced consumer equipment then this switch should be used to reduce the output levels by 10dB.

Meter Characteristic Selection - DIPSwitch 7

This DIPSwitch changes the metering characteristics between VU (off) and PPM (on).

Mute Speaker Output - DIPSwitch 8

This DIPSwitch will mute the speaker output when switched on. This will allow the unit to use the audio output to drive external speakers only.

DIPSwitches 2,4,6 are reserved for future use and should be left in the off position.

Technical Specification RM-CA2 & RM-CAD8

Inputs	
Audio Inputs (RM-CA2):	2 x stereo analogue (1 x XLR balanced, 1 x XLR balanced or RCA phono unbal)
Audio Inputs (RM-CAD8):	2 x stereo analogue (1 x XLR balanced, 1 x XLR balanced or RCA phono unbal) 4 x stereo XLR balanced AES/EBU digital 1 x stereo RCA phono S/PDIF digital 1 x stereo optical TOSLink digital
Max Level (0dB Input Gain):	+18dBu (analogue)/0dBFS (digital)
CMRR:	>60dB typical
Analogue Input Impedances:	XLR: >20k Ω balanced bridging RCA: >10k Ω unbalanced
Digital Input Impedances (RM-CAD8 only):	110 Ω \pm 20% AES/EBU balanced I/O 75 Ω \pm 5% S/PDIF unbalanced I/O
AES/EBU Sample Rate: (RM-CAD8 only):	32 to 96kHz, converted internally to 48kHz
Input Gain:	+10dB on unbalanced analogue input
Selection:	Front panel push button with indicator LEDs
Line Level Outputs	
Audio Outputs:	1 x stereo analogue
Gain re Selected Input:	Unity or -10dB (switchable) & level control from front panel
Maximum Output Level:	+18dB
Output Impedance:	<50 ohms
Distortion:	<0.02% (1kHz, +8dBu output)
Noise:	-95dB RMS, unity gain ref +8dBu output

Frequency Response: 20Hz-20kHz +0/-0.5dB

Crosstalk Analogue I/O, ref 0dB
1kHz input: <-90dB
10kHz input: <-85dB

Amplifier/Loudspeakers

Configuration: Three-way with stereo mid/high-frequency drivers & mono low-frequency driver

Power Output: 2 x 7W (HF) + 15W (LF) with protective limiter

Crossover: 250Hz (24dB/octave, Linkwitz-Riley)

Distortion (HF Outputs): < 0.1% (1kHz, 3W output)

Distortion (LF Output): < 0.1% (100Hz, 6W output)

Noise: More than 102dB below full output

Volume: Mute to full volume via front panel rotary control (mute, -52 to +18dB)

Balance Trim: \pm 6dB via front panel rotary control.

Peak Acoustic Level: 96dB SPL @ 2ft

Level & Phase Metering

Number: 2 x 8-segment LED bargraphs

Line-Up Level: 0dB on scale can be set to 0dB or -10dB for analogue input 2 via rear panel DIP switch

Phase Meter: Single LED indication showing error

Connectors

Audio Inputs (RM-CA2): 4 x XLR 3-pin female balanced
2 x RCA female phono unbalanced

Audio Inputs (RM-CAD8):	4 x XLR 3-pin female analogue 2 x RCA phono analogue 4 x XLR 3-pin female AES/EBU digital 1 x RCA phono female S/PDIF digital 1 x optical TosLink digital
Audio Outputs:	2 x XLR 3-pin male (balanced, may be unbalanced)
Headphones:	1/4" (6.35mm) A-gauge 3-pole stereo jack socket
Mains Input:	Filtered 3-pin IEC male, continuously rated 85 - 264VAC, 47 - 63Hz, fused, 60W peak, 30W average
Fuse Rating:	Anti-surge fuse 2A 20 x 5mm

Equipment Type

RM-CA2:	Confidence Monitor, 2 LED meters, 2 analogue stereo inputs
RM-CAD8:	Confidence Monitor, 2 LED meters, 2 analogue & 6 digital stereo inputs

Physical Specification

Dimensions (Raw):	48cm (W) x 27cm (D) x 4.4cm (H) (1U) 19" (W) x 12" (D) x 1.73" (H) (1U)
Dimensions (Boxed):	57cm (W) x 52cm (D) x 15cm (H) 22.4" (W) x 20.5" (D) x 5.9" (H)
Weight:	Nett: 4.5kg Gross: 6kg Nett: 10lb Gross: 13.2lb

SONIFEX

www.sonifex.co.uk

t:+44 (0)1933 650 700

f:+44 (0)1933 650 726

sales@sonifex.co.uk