

Passive Packs

CM-HPR1	Headphone Volume Control
CM-HPX1	Headphone Volume Control
CM-ULR1	Unbalanced to Balanced Audio Converter
CM-ULX1	Unbalanced to Balanced Audio Converter
CM-LUR1	Balanced to Unbalanced Audio Converter
CM-LUX1	Balanced to Unbalanced Audio Converter
CM-AESX3	3 Way Passive Digital AES3 Splitter, with XLR
CM-AESB3	3 Way Passive Digital AES3ID Splitter, with BNC
CM-MS3	3 Way Passive Microphone Splitter



Manufacturers of audio & video
products for radio & TV broadcasters

SONIFEX

For the latest Sonifex handbook information please visit the Sonifex website at www.sonifex.co.uk

This handbook is for use with the following product:
CM-HPR1, CM-HPX1, CM-ULR1, CM-ULX1, CM-LUR1, CM-LUX1,
CM-AESB3, CM-AESX3, CM-MS3
Stock Code: 30-365
Artwork: AW10865A

©Sonifex Ltd, 2017
All Rights Reserved
Revision 1.00, August 2017

Sonifex Ltd, 61, Station Road, Irthlingborough,
Northants, NN9 5QE, England.
Tel: +44 (0)1933 650 700
Fax: +44 (0)1933 650 726
Email: sales@sonifex.co.uk
Website: <http://www.sonifex.co.uk>

Information in this document is subject to change without notice and does not represent a commitment on the part of the vendor. Sonifex Ltd shall not be liable for any loss or damage whatsoever arising from the use of information or any error contained in this manual.

No part of this manual may be reproduced or transmitted in any form or by any means, electronic or mechanical, including photocopying, recording, information storage and retrieval systems, for any purpose other than the purchaser's personal use, without the express written permission of Sonifex Ltd. Unless otherwise noted, all names of companies, products and persons contained herein are part of a completely fictitious adaptation and are designed solely to document the use of Sonifex product.

Contents

Register Online for an Extended
2 Year Warranty

Product Warranty - 2 Year Extended

	i		
	ii		
Sonifex Warranty & Liability Terms & Conditions	ii		
1. Definitions	ii		
2. Warranty	iii		
Unpacking Your Product	vi		
Repairs & Returns	vii		
CE Conformity	vii		
WEEE Directive	viii		
Atmosphere/Environment	viii		
Passive Packs	1		
CM-MNT1 Desk Mount Panel	1		
CM-HPR1 & CM-HPX1 Headphone Volume Controls	2		
Block Diagrams	4		
Connectors & Controls	4		
Analogue Inputs CM-HPX1	4		
Analogue Inputs CM-HPR1	5		
Technical Spec CM-HPR1/CM-HPX1	5		
CM-ULR1 & CM-ULX1 Unbalanced to Balanced Audio Converters	6		
Block Diagrams	8		
		Connectors & Controls	8
		Technical Spec CM-ULR1/CM-ULX1	9
		CM-LUR1 & CM-LUX1 Balanced to Unbalanced Audio Converters	10
		Block Diagrams	12
		Connectors & Controls	13
		Technical Spec CM-LUR1/CM-LUX1	14
		CM-AESX3 3 Way Passive Digital AES3 Splitter, with XLR	15
		Block Diagram	16
		Connectors & Controls	16
		Technical Specification CM-AESX3	18
		CM-AESB3 3 Way Passive Digital AES3ID Splitter, with BNC	19
		Block Diagram	20
		Controls & Connectors	20
		Technical Specification CM-AESB3	21
		CM-MS3 Single 3 Way Passive Microphone Splitter	22
		Block Diagram	23
		Controls & Connectors	24
		Technical Specification CM-MS3	26

Figures

Fig A:	CM-MNT1 Desk-Mount Plate Fitted On CM-ULX1	1	Fig 2-6:	CM-LUR1 Front & Rear View	10
Fig B:	CM-MNT1 Desk-Mount Plate With Screws	1	Fig 2-7:	CM-LUX1 Front & Rear View	11
Fig 1-1:	CM-HPR1 Front & Rear View	2	Fig 2-8:	CM-LUX1 Application Diagram	12
Fig 1-2:	Application Example Using Axia Xnode	3	Fig 2-9:	CM-LUR1 Block Diagram	12
Fig 1-3:	CM-HPX1 Front & Rear View	3	Fig 2-10:	CM-LUX1 Block Diagram	12
Fig 1-4:	CM-HPR1 Block Diagram	4	Fig 3-1:	CM-AESX3 Front & Rear View	15
Fig 1-5:	CM-HPX1 Block Diagram	4	Fig 3-2:	CM-AESX3 Block Diagram	16
Fig 2-1:	CM-ULR1 Front & Rear View	6	Fig 3-3:	CM-AESX3 Examples of use of Cumulative Cabling	17
Fig 2-2:	CM-ULX1 Application Diagram	7	Fig 3-4:	CM-AESB3 Front & Rear View	19
Fig 2-3:	CM-ULX1 Front & Rear View	7	Fig 3-5:	CM-AESB3 Block Diagram	20
Fig 2-4:	CM-ULR1 Block Diagram	8	Fig 3-6:	CM-MS3 Front & Rear View	22
Fig 2-5:	CM-ULX1 Block Diagram	8	Fig 3-7:	CM-MS3 Block Diagram	23
			Fig 3-8:	CM-MS3 Examples of Usage	23

SONIFEX

Register Online for an Extended 2 Year Warranty

Product: _____

Serial No: _____

As standard, Sonifex products are supplied with a 1 year back to base warranty. If you register the product online, you can increase your product warranty to 2 years and we can also keep you informed of any product design improvements or modifications.

To register your product, please go online to www.sonifex.co.uk/register

Product Warranty - 2 Year Extended

As standard, Sonifex products are supplied with a 1 year back to base warranty. In order to register the date of purchase and so that we can keep you informed of any product design improvements or modifications, it is important to complete the warranty registration online. Additionally, if you register the product on the Sonifex website, you can increase your product warranty to 2 years. Go to the Sonifex website at: www.sonifex.co.uk/register to apply for your 2 year warranty.

Sonifex Warranty & Liability Terms & Conditions

1. Definitions

‘the Company’ means Sonifex Ltd and where relevant includes companies within the same group of companies as Sonifex Limited.

‘the Goods’ means the goods or any part thereof supplied by the Company and where relevant includes: work carried out by the Company on items supplied by the Purchaser; services supplied by the Company; and software supplied by the Company.

‘the Purchaser’ means the person or organisation who buys or has agreed to buy the Goods.

‘the Price’ means the Price of the Goods and any other charges incurred by the Company in the supply of the Goods.

‘the Warranty Term’ is the length of the product warranty which is usually 12 months from the date of despatch; except when the product has been registered at the Sonifex website when the Warranty Term is 24 months from the date of despatch.

‘the Contract’ means the quotation, these Conditions of Sale and any other document incorporated in a contract between the Company and the Purchaser.

This is the entire Contract between the parties relating to the subject matter hereof and may not be changed or terminated except in writing in accordance with the provisions of this Contract. A reference to the consent, acknowledgement, authority or agreement of the Company means in writing and only by a director of the Company.

2. Warranty

- a. The Company agrees to repair or (at its discretion) replace Goods which are found to be defective (fair wear and tear excepted) and which are returned to the Company within the Warranty Term provided that each of the following are satisfied:
 - i. notification of any defect is given to the Company immediately upon its becoming apparent to the Purchaser;
 - ii. the Goods have only been operated under normal operating conditions and have only been subject to normal use (and in particular the Goods must have been correctly connected and must not have been subject to high voltage or to ionising radiation and must

Warranty

- not have been used contrary to the Company's technical recommendations);
 - iii. the Goods are returned to the Company's premises at the Purchaser's expense;
 - iv. any Goods or parts of Goods replaced shall become the property of the Company;
 - v. no work whatsoever (other than normal and proper maintenance) has been carried out to the Goods or any part of the Goods without the Company's prior written consent;
 - vi. the defect has not arisen from a design made, furnished or specified by the Purchaser;
 - vii. the Goods have been assembled or incorporated into other goods only in accordance with any instructions issued by the Company;
 - viii. the defect has not arisen from a design modified by the Purchaser;
 - ix. the defect has not arisen from an item manufactured by a person other than the Company. In respect of any item manufactured by a person other than the Company, the Purchaser shall only be entitled to the benefit of any warranty or guarantee provided by such manufacturer to the Company.
- b. In respect of computer software supplied by the Company the Company does not warrant that the use of the software will be uninterrupted or error free.

- c. The Company accepts liability:
- (i) for death or personal injury to the extent that it results from the negligence of the Company, its employees (whilst in the course of their employment) or its agents (in the course of the agency);
 - (ii) for any breach by the Company of any statutory undertaking as to title, quiet possession and freedom from encumbrance.
- d. Subject to conditions (a) and (c) from the time of despatch of the Goods from the Company's premises the Purchaser shall be responsible for any defect in the Goods or loss, damage, nuisance or interference whatsoever consequential economic or otherwise or wastage of material resulting from or caused by or to the Goods. In particular the Company shall not be liable for any loss of profits or other economic losses. The Company accordingly excludes all liability for the same.
- e. At the request and expense of the Purchaser the Company will test the Goods to ascertain performance levels and provide a report of the results of that test. The report will be accurate at the time of the test, to the best of the belief and knowledge of the Company, and the Company accepts no liability in respect of its accuracy beyond that set out in Condition (a).
- f. Subject to Condition (e) no representation, condition, warranty or other term, express or implied (by statute or otherwise) is given by the Company that the Goods are of any particular quality or standard

or will enable the Purchaser to attain any particular performance or result, or will be suitable for any particular purpose or use under specific conditions or will provide any particular capacity, notwithstanding that the requirement for such performance, result or capacity or that such particular purpose or conditions may have been known (or ought to have been known) to the Company, its employees or agents.

- g. (i) To the extent that the Company is held legally liable to the Purchaser for any single breach of contract, tort, representation or other act or default, the Company's liability for the same shall not exceed the price of the Goods.
- (ii) The restriction of liability in Condition (g)(i) shall not apply to

any liability accepted by the Seller in Condition (c).

- h. Where the Goods are sold under a consumer transaction (as defined by the Consumer Transactions (Restrictions on Statements) Order 1976) the statutory rights of the Purchaser are not affected by these Conditions of Sale.

Unpacking Your Product

Each product is shipped in protective packaging and should be inspected for damage before use. If there is any transit damage take pictures of the product packaging and notify the carrier immediately with all the relevant details of the shipment. Packing materials should be kept for inspection and also for if the product needs to be returned.

The product is shipped with the following equipment so please check to ensure that you

have all of the items below. If anything is missing, please contact the supplier of your equipment immediately.

Item	Quantity
Product unit	1
Handbook and warranty card	1

Repairs & Returns

Please contact Sonifex or your supplier if you have any problems with your Sonifex product. Email technical.support@sonifex.co.uk for the repair/upgrade/returns procedure, or for support & questions regarding the product operation.

CE Conformity

The products in this manual comply with the essential requirements of the relevant European health, safety and environmental protection legislation.

The technical justification file for this product is available at Sonifex Ltd.

The declaration of conformity can be found at: <http://www.sonifex.co.uk/declarations>

WEEE Directive



The Waste Electrical and Electronic Equipment (WEEE) Directive was agreed on 13 February 2003, along with the related Directive

2002/95/EC on Restrictions of the use of certain Hazardous Substances in electrical and electronic equipment (RoHS). The Waste Electrical and Electronic Equipment Directive (WEEE) aims to minimise the impacts of electrical and electronic equipment on the environment during their life times and when they become waste. All products manufactured by Sonifex Ltd have the WEEE directive label placed on the case. Sonifex Ltd will be happy to give you information about local organisations that can reprocess the product when it reaches its “end of use”, or alternatively all products that have reached “end of use” can be returned to Sonifex and will be reprocessed correctly free of charge.

viii

Atmosphere/Environment

This apparatus should be installed in an area that is not subject to excessive temperature variation ($<0^{\circ}\text{C}$, $>50^{\circ}\text{C}$), moisture, dust or vibration.

This apparatus shall not be exposed to dripping or splashing, and no objects filled with water, such as vases shall be placed on the apparatus.

Passive Packs

The passive packs are a range of small utility products which use transformers to change audio input & output impedances and levels and to distribute audio signals.

There are a range of different products to suit different needs:

CM-HPR1 Headphone Volume Control

CM-HPX1 Headphone Volume Control

CM-ULR1 Unbal to Bal Audio Converter

CM-ULX1 Unbal to Bal Audio Converter

CM-LUR1 Bal to Unbal Audio Converter

CM-LUX1 Bal to Unbal Audio Converter

CM-AESX3 3 Way Dig AES3 Splitter, XLR

CM-AESB3 3 Way Dig AES3ID Splitter, BNC

CM-MS3 3 Way Microphone Splitter

CM-MNT1 Desk Mount Panel

All of the products, along with the CM-TBU and CM-TLL, can be mounted to the underside of a desk using the CM-MNT1 desk mount plate. This fixes to the top side of the product and screws to the underside of a surface.



Fig A: CM-MNT1 Desk-Mount Plate Fitted On CM-ULX1



Fig B: CM-MNT1 Desk-Mount Plate With Screws

CM-HPR1 & CM-HPX1 Headphone Volume Controls

These two products allow the connection of a stereo balanced line input (RJ45 on the CM-HPR1 with StudioHub+™ pinout and 2 x female XLRs on the CM-HPX1) and create a headphone output, with level control.



StudioHub+™ is a registered trademark of Radio Systems Inc

They are transformer balanced, and can be used with any headphones above 150Ω impedance.

The transformer ratio of 2:1 ensures that any headphone load presented at the output is reflected through to the input at a 1:4 ratio (hence a 150Ω set of headphones looks like 600Ω at the input, a suitable load for most good quality line output stages).

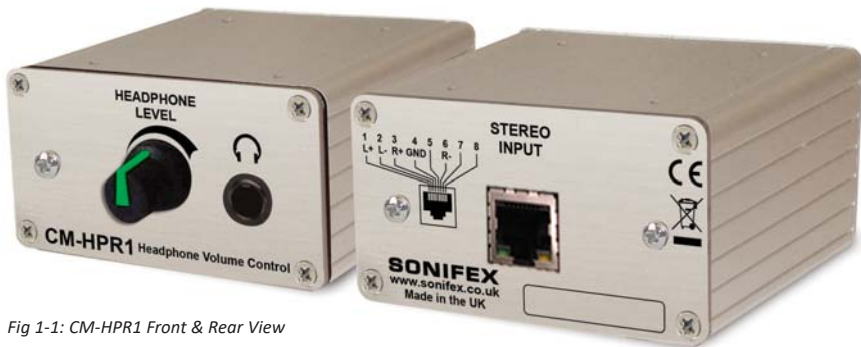

Fig 1-1: CM-HPR1 Front & Rear View

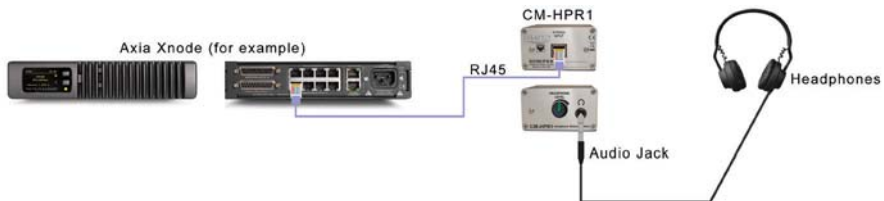

Fig 1-2: Application Example Using Axia Xnode

Axia® is a registered trademark of TLS Corp



Fig 1-3: CM-HPX1 Front & Rear View

Block Diagrams

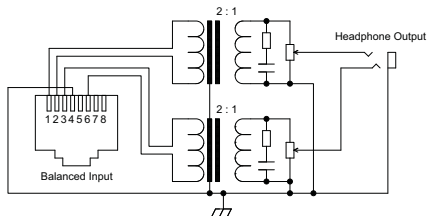

Fig 1-4: CM-HPR1 Block Diagram

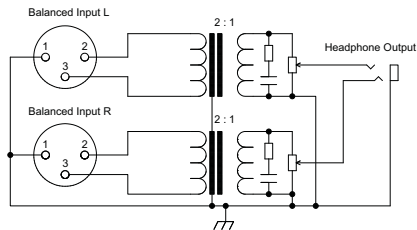

Fig 1-5: CM-HPX1 Block Diagram

Connectors & Controls

Headphone Output

The stereo headphone output uses a stereo 6.35mm jack socket with the following connections:

Pin Type	Connection
Tip:	Left
Ring:	Right
Screen:	Ground

The headphone level will be at half the level of the incoming signal with the volume control at 100%.

Volume Level Control

The volume level control sets the output level of the stereo headphone socket and runs logarithmically from zero to the maximum output level.

Analogue Inputs CM-HPX1

The stereo analogue input is on two female 3 pin XLR connectors with the following pin assignments:

Pin 1: 0V Common

Pin 2: Phase

Pin 3: Non Phase

Analogue Inputs CM-HPR1

The stereo analogue input is on a female RJ45 connector with the following standard StudioHub+™ pin assignments:

Pin No.	Connection
1	Left Phase
2	Left Non-Phase
3	Right Phase
4	Ground
5	N/C
6	Right Non-Phase
7	N/C
8	N/C

Technical Spec CM-HPR1/CM-HPX1

Audio Specification	
Input/Output Level Ratio:	2:1
Input/Output Impedance Ratio:	4:1
Minimum Headphone Impedance:	150Ω
Max Input Level:	+28dBu
Max Output Level:	+22dBu

Frequency Response:	20Hz to 20kHz, +0/-0.5dB
Noise:	<-115dBu A-wgtd
Distortion Ref +8dBu (Output):	<0.01%
Common Mode Rejection:	>80dB

Connections

Main Stereo Input (CM-HPX1):	2 x XLR 3 pin, female
Main Stereo Input (CM-HPR1):	1 x RJ45 female StudioHub+™ pinout
Output:	¼" (6.35mm) A/B gauge 3-pole stereo jack sockets

Equipment Type

CM-HPX1:	Headphone volume control, XLR input
CM-HPR1:	Headphone volume control, RJ45 input

Physical Specification

Dimensions (Raw):	7.7cm (W) x 8.3cm (D) x 4.2cm (H) 3.0" (W) x 3.3" (D) x 1.7" (H)
Weight:	Nett: 0.22kg Gross: 0.33kg Nett: 0.49lbs Gross: 0.73lbs

CM-ULR1 & CM-ULX1 Unbalanced to Balanced Audio Converters

These two products allow the connection of a stereo unbalanced line input on phono connectors to a balanced line output (RJ45 on the CM-ULR1 with StudioHub+™ pinout, 2 x male XLRs on the CM-ULX1).



StudioHub+™ is a registered trademark of Radio Systems Inc

They are transformer balanced, with a 1:2 ratio, so 6dB of gain is added to the input to help interface with the higher signal levels associated with professional outputs.

These units are passive versions of the RB-UL1, and provide you with an alternative to wiring an unbalanced output directly into a balanced input.



Fig 2-1: CM-ULR1 Front & Rear View

By placing one of these boxes close to the unbalanced output (before the cable run to the balanced input), the connection will benefit from the input device's common mode rejection capabilities, reducing noise and interference.

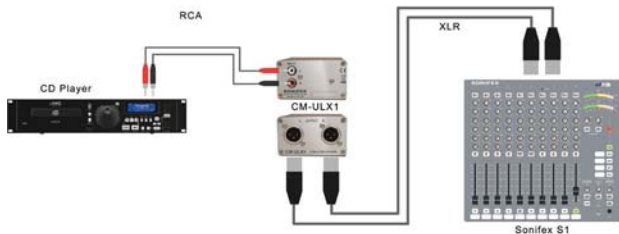

Fig 2-2: CM-ULX1 Application Diagram



Fig 2-3: CM-ULX1 Front & Rear View

Block Diagrams

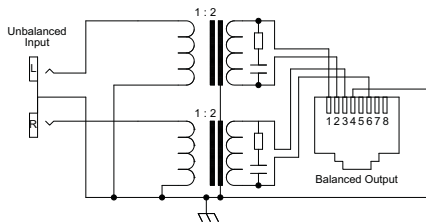

Fig 2-4: CM-ULR1 Block Diagram

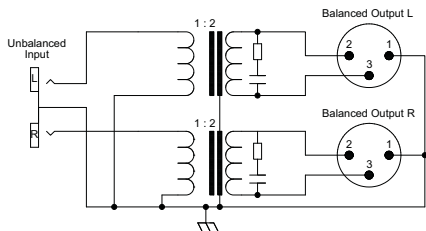

Fig 2-5: CM-ULX1 Block Diagram

Connectors & Controls

RCA Phono Inputs

Both units use a stereo unbalanced line phono connector with the following connections:

Pin Type	Connection
White Tip:	Left
White Screen:	Ground
Red Tip:	Right
Red Screen:	Ground

Analogue Outputs CM-ULR1

The stereo balanced line output is on a female RJ45 connector with the following standard StudioHub+™ pin assignments:

Pin No.	Connection
1	Left Phase
2	Left Non-Phase
3	Right Phase
4	Ground
5	N/C
6	Right Non-Phase
7	N/C
8	N/C

Analogue Outputs CM-ULX1

The stereo analogue balanced line output is on two male 3 pin XLR connectors with the following pin assignments:

Pin 1: 0V Common

Pin 2: Phase

Pin 3: Non Phase

Technical Spec CM-ULR1/CM-ULX1

Audio Specification	
Input/Output Level Ratio:	1:2
Input/Output Impedance Ratio:	1:4
Max Input Level:	+22dBu
Max Output Level:	+28dBu
Frequency Response:	20Hz to 20kHz, +0/-0.5dB
Noise:	<-100dBu A-wgtd
Distortion Ref +8dBu (Output):	<0.02%

Connections	
Stereo Unbalanced Line Input (CM-ULR1 & CM-ULX1):	2 x RCA phono connectors
Balanced Line Output (CM-ULR1):	1 x RJ45 female StudioHub+™ pinout
Balanced Line Output (CM-ULX1):	2 x male XLRs
Equipment Type	
CM-ULR1:	Unbalanced to balanced audio converter, RJ45 output
CM-ULX1:	Unbalanced to balanced audio converter, XLR output
Physical Specification	
Dimensions (Raw):	7.7cm (W) x 8.3cm (D) x 4.2cm (H) 3.0" (W) x 3.3" (D) x 1.7" (H)
Weight:	Nett: 0.22kg Gross: 0.33kg Nett: 0.49lbs Gross: 0.73lbs

CM-LUR1 & CM-LUX1 Balanced to Unbalanced Audio Converters

These two products allow the connection of a stereo balanced line input (RJ45 on the CM-LUR1 with StudioHub+™ pinout, 2 x female XLRs on the CM-LUX1) to a stereo unbalanced output on stereo phono connectors.

They are transformer balanced, with a 2:1 ratio, so 6dB of attenuation is added to the input to help interface with the lower signal levels associated with consumer outputs.



StudioHub+™ is a registered trademark of Radio Systems Inc



Fig 2-6: CM-LUR1 Front & Rear View

These units are passive versions of the RB-LU4 (though only 1 x stereo channel), and provide you with an alternative to having to interface a balanced output to an unbalanced input via specialist cables (either by shorting the non-phase to ground or disconnecting it).

They are particularly useful where a shared balanced audio feed needs interfacing to an unbalanced input on one or more pieces of equipment. Using a CM-LUR1 or CM-LUX1 galvanically isolates the audio, allowing you to connect via phono cables to an unbalanced input without compromising the distributed feed.



Fig 2-7: CM-LUX1 Front & Rear View

2 Passive Matching Converters

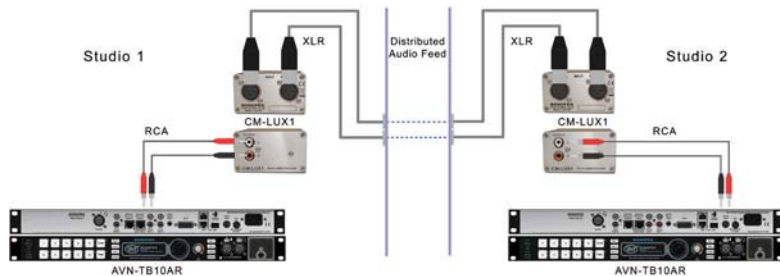

Fig 2-8: CM-LUX1 Application Diagram

Block Diagrams

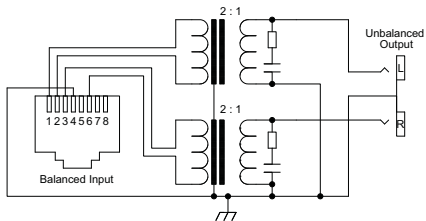

Fig 2-9: CM-LUR1 Block Diagram

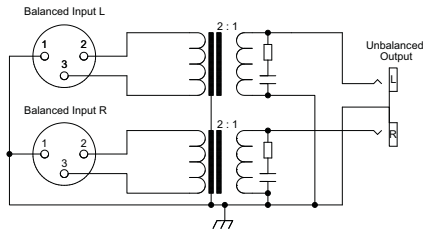

Fig 2-10: CM-LUX1 Block Diagram

Connectors & Controls

Analogue Inputs CM-LUR1

The stereo analogue input is on a female RJ45 connector with the following standard StudioHub+™ pin assignments:

Pin No.	Connection
1	Left Phase
2	Left Non-Phase
3	Right Phase
4	Ground
5	N/C
6	Right Non-Phase
7	N/C
8	N/C

Analogue Inputs CM-LUX1

The stereo analogue input is on two female 3 pin XLR connectors with the following pin assignments:

Pin 1: 0V Common

Pin 2: Phase

Pin 3: Non Phase

RCA Phono Analogue Outputs (CM-LUR1 & CM-LUX1)

Both units use a stereo unbalanced line output on a RCA phono connector with the following connections:

Pin Type	Connection
White Tip:	Left
White Screen:	Ground
Red Tip:	Right
Red Screen:	Ground

Technical Spec CM-LUR1/CM-LUX1

Audio Specification	
Input/Output Level Ratio:	2:1
Input/Output Impedance Ratio:	4:1
Max Input Level:	+28dBu
Max Output Level:	+22dBu
Frequency Response:	20Hz to 20kHz, +0/-0.5dB
Noise:	<-115dBu A-wgtd
Distortion Ref +8dBu (Output):	<0.01%
Common Mode Rejection:	>80dB
Connections	
Balanced Line Input (CM-LUR1):	1 x RJ45 female StudioHub+™ pinout
Balanced Line Input (CM-LUX1):	2 x female XLRs
Unbalanced Line Output (CM-LUR1 & CM-LUX1):	2 x RCA phono connectors

Equipment Type	
CM-LUR1:	Balanced to unbalanced audio converter, RJ45 input
CM-LUX1:	Balanced to unbalanced audio converter, XLR input
Physical Specification	
Dimensions (Raw):	7.7cm (W) x 8.3cm (D) x 4.2cm (H) 3.0" (W) x 3.3" (D) x 1.7" (H)
Weight:	Nett: 0.22kg Gross: 0.33kg Nett: 0.49lbs Gross: 0.73lbs

CM-AESX3 3 Way Passive Digital AES3 Splitter, with XLR

The CM-AESX3 is a passive digital splitter, designed to split a single AES3 source to up to three destinations, using Neutrik XLR connectors. 110 Ω termination can be applied,

if desired to unconnected outputs. The CM-AESX3 is a single “one-to-three” splitter housed in a small form box, and utilises a locking XLR socket for the input connector.



Fig 3-1: CM-AESX3 Front & Rear View

Block Diagram

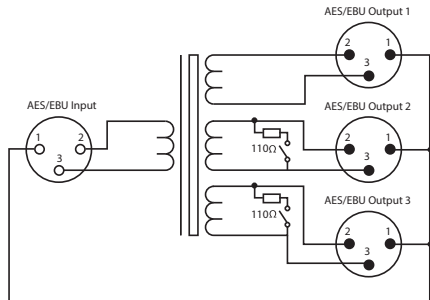

Fig 3-2: CM-AESX3 Block Diagram

Connectors & Controls

AES/EBU Input(s)

Both units use a stereo balanced line input on a RCA phono connector with the following connections:

The single digital audio input is via a female XLR connector with the following pin assignment:

Pin 1: 0V Common

Pin 2: Phase

Pin 3: Non Phase

AES/EBU Outputs 1-3

The digital audio outputs are via male XLR connectors with the following pin assignment:

Pin 1: 0V Common

Pin 2: Phase

Pin 3: Non Phase

Termination Switches

It is possible to terminate Output 2 and Output 3 with 110Ω in the event that they are not connected to a destination device. It may be necessary to remove termination from an unused output if a used output is connected to a destination via a long cable run, in order to increase the level of the AES3 carrier signal.

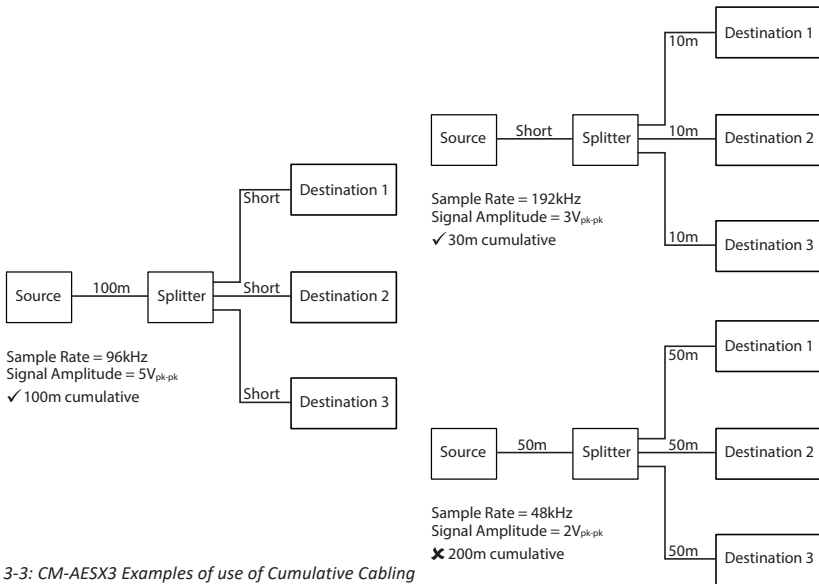

Fig 3-3: CM-AESX3 Examples of use of Cumulative Cabling

Technical Specification CM-AESX3

CM-AESX3: Cable Drive Capability

The table below sets out the minimum signal amplitude required to drive 100m (cumulative) of 110Ω twisted pair cable, based on the sample rate of the digital audio:

Sample Rate	Minimum Signal Amplitude
32kHz	*2Vpk-pk
44.1kHz	*2Vpk-pk
48kHz	*2Vpk-pk
88.2kHz	5Vpk-pk
96kHz	5Vpk-pk

* Minimum of 2Vpk-pk is defined by the AES3 format specification.

The table below sets out the minimum signal amplitude required to drive 30m (cumulative) of 110Ω twisted pair cable, based on the sample rate of the digital audio:

Sample Rate Minimum Signal Amplitude

176.4kHz 3Vpk-pk

192kHz 3Vpk-pk

Equipment Type

CM-AESX3: 3 Way passive digital AES3 splitter with XLR connections.

Physical Specification

Dimensions: 7.7cm (W) x 8.3cm (D)
 (Raw): x 4.2cm (H)
 3.0" (W) x 3.3" (D) x 1.7" (H)

Weight: Nett: 0.22kg Gross: 0.33kg

 Nett: 0.49lbs Gross: 0.73lbs

CM-AESB3 3 Way Passive Digital AES3ID Splitter, with BNC

The CM-AESB3 is a passive digital splitter, designed to split a single AES3ID source to up to three destinations, using BNC connectors. 75Ω termination can be applied, if desired

to unconnected outputs. The CM-AESB3 is a single “one-to-three” splitter housed in a small form box.



Fig 3-4: CM-AESB3 Front & Rear View

Block Diagram

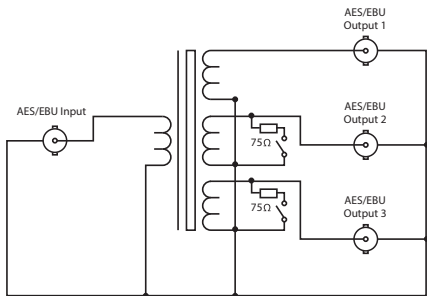

Fig 3-5: CM-AESB3 Block Diagram

Controls & Connectors

AES/EBU Input(s)

The single digital audio input is via a female BNC connector with the following pin assignment:

Tip: Signal

Screen: 0V Common

AES/EBU Outputs 1-3

The digital audio outputs are via a female BNC connectors with the following pin assignment:

Tip: Signal

Screen: 0V Common

Termination Switches

It is possible to terminate Output 2 and Output 3 with 75Ω in the event that they are not connected to a destination device. It may be necessary to remove termination from an unused output if a used output is connected to a destination via a long cable run, in order to increase the level of the AES3ID carrier signal.

Technical Specification CM-AESB3

CM-AESB3: Cable Drive Capability

Cumulative cable drive capability of 100m of 75Ω coaxial cable at sample rates up to and including 96kHz.

Equipment Type

CM-AESB3: 3 Way passive digital AES3ID splitter with BNC.

Physical Specification

Dimensions (Raw): 7.7cm (W) x 8.3cm (D) x 4.2cm (H)
3.0" (W) x 3.3" (D) x 1.7" (H)

Weight: Nett: 0.22kg Gross: 0.33kg
Nett: 0.49lbs Gross: 0.73lbs

CM-MS3 Single 3 Way Passive Microphone Splitter

The CM-MS3 is a passive microphone splitter, designed to split the signal from a single mic or line source, to up to 3 destinations, whilst allowing the operator to pass phantom power

back from mic preamplifier inputs, or apply +48VDC power directly from the unit. Pin 1 “ground” lifts are provided to eliminate ground loop problems.



Fig 3-6: CM-MS3 Front & Rear View

Block Diagram

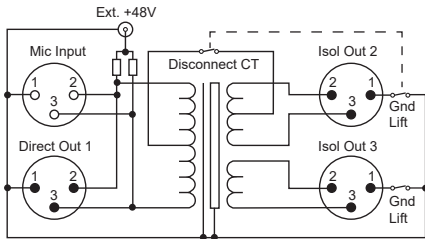

Fig 3-7: CM-MS3 Block Diagram

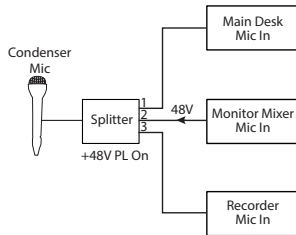
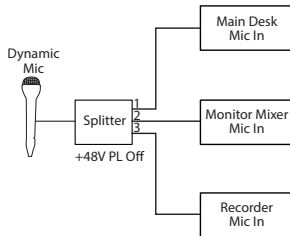
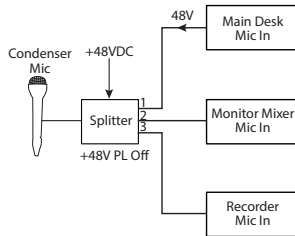

Fig 3-8: CM-MS3 Examples of Usage

Controls & Connectors

Front Panel

Input

The XLR 3 pin input socket is transformer balanced and is capable of accepting a dynamic or phantom powered microphone, or a line level signal up to +18dBu (without the 30dB pad applied). The input socket has the following connections:

Pin 1: Screen

Pin 2: Phase

Pin 3: Non Phase

Output 1 (Direct)

The XLR 3 pin plug is a parallel connection of the input. It is therefore possible to supply phantom power to the splitter input by connecting output 1 to a phantom powered microphone preamplifier. The output 1 plug has the following connections:

Pin 1: Screen

Pin 2: Phase

Pin 3: Non Phase

External +48VDC Phantom Power

External phantom power (+48V) can be applied to the input by connecting a supply to the DC power connector (2.5mm pin). The pinout is as follows:

Phantom Powering Guidance

It is possible to pass phantom power to the splitter input by three different methods:

- Via the external +48V DC connector.
- From a mic pre-amp connected to direct output (output 1).
- From a mic pre-amp connected to output 2 (provided phantom loopback is enabled).

It is therefore possible to concurrently power the microphone using any two of the above methods (for power redundancy) without causing signal degradation. It is important the output connectors are grounded (and not lifted) should the external phantom power be connected, to prevent hum/hiss caused by ground loop currents.

Important: A maximum of two phantom powering methods can be used concurrently.

Rear Panel

Output 2 (+48V PL Phantom Loopback)

The XLR 3 pin plug is a transformer isolated output. A switchable centre tap connection makes it possible to supply phantom power to the splitter input by connecting output 2 to a phantom powered microphone preamplifier,

and setting the adjacent push switch to the “PL ON” position. The output 2 plug has the following connections:

Pin 1: Screen (Can be grounded or lifted by adjacent push switch)

Pin 2: Phase

Pin 3: Non Phase

Output 3

The XLR 3 pin plug is a transformer isolated output and has the following connections:

Pin 1: Screen (Can be grounded or lifted by adjacent push switch)

Pin 2: Phase

Pin 3: Non Phase

3 Passive Splitters

Technical Specification CM-MS3

Test	Conditions	Result
Frequency Response:	<ul style="list-style-type: none">• Ref. -6dBu, 1kHz• Source Impedance = 150Ω• Load Impedance = 10kΩ	10Hz - 30kHz \pm 0.5dB
Total Harmonic Distortion:	<ul style="list-style-type: none">• Ref. +3dBu, 50Hz• Source Impedance = 150Ω• Load Impedance = 10kΩ	0.02%
Total Harmonic Distortion 0.1%:	<ul style="list-style-type: none">• Ref. 0.1%THD+N, 50Hz• Source Impedance = 150Ω• Load Impedance = 10kΩ	+13dBu
Total Harmonic Distortion 1%:	<ul style="list-style-type: none">• Ref. 1%THD+N, 50Hz• Source Impedance = 150Ω• Load Impedance = 10kΩ	+18dBu
Common Mode Rejection Ratio:	<ul style="list-style-type: none">• Ref. 20kHz• Source Impedance = 600Ω• Load Impedance = 10kΩ	>60dB
Equipment Type		
CM-MS3	Single 3 way passive microphone splitter.	

Physical Specification

Dimensions (Raw): 7.7cm (W) x 8.3cm (D) x 4.2cm (H)
3.0" (W) x 3.3" (D) x 1.7" (H)

Weight: Nett: 0.30kg Gross: 0.40kg
Nett: 0.66lbs Gross: 0.88lbs

SONIFEX

www.sonifex.co.uk

t:+44 (0)1933 650 700

f:+44 (0)1933 650 726

sales@sonifex.co.uk